

THE CHEOPS CALIBRATION BENCH

F. Wildi¹, B. Chazelas¹, A. Deline¹, M. Sarajlic¹, M. Sordet¹

¹ University of Geneva, Astronomy dept., 51 ch. des Maillettes, CH-1290 Sauverny, Switzerland.

I. INTRODUCTION:

CHEOPS is an ESA Class S Mission aiming at the characterization of exoplanets through the precise measurement of their radius, using the transit method [1]. To achieve this goal, the payload is designed to be a high precision “absolute” photometer, looking at one star at a time. It will be able to cover a large fraction of the sky by repointing. Its launch is expected at the end of 2017 [2, this conference].

CHEOPS’ main science is the measure of the transit of exoplanets of radius ranging from 1 to 6 Earth radii orbiting bright stars. The required photometric stability to reach this goal is of 20 ppm in 6 hours for a 9th magnitude star.



Fig 1. Artist view of the CHEOPS satellite L/h, CHEOPS instrument STM during AIV R/h.

The CHEOPS’ only instrument is a Ritchey-Chretien style telescope with 300 mm effective aperture diameter, which provides a defocused image of the target star on a single frame-transfer backside illuminated CCD detector cooled to -40°C and stabilized within ~ 10 mK [2]. CHEOPS being in a LEO, it is equipped with a high performance baffle. The spacecraft platform provides a pointing stability of < 2 arcsec rms. This relatively modest pointing performance makes high quality flat-fielding necessary

In the rest of this article we will refer to the only CHEOPS instrument simply as “CHEOP” Its behavior will be calibrated thoroughly on the ground and only a small subset of the calibrations can be redone in flight. The main focuses of the calibrations are the photonic gain stability and sensibility to the environment variations and the Flat field that has to be known at a precision better than 0.1%.

To this purpose, a significant effort has been placed in the development of a CHEOPS calibration system. This system produces very stable illumination patterns for CHEOPS: either a very uniform illumination on the Field of View of the instrument or an artificial star that can be steered to any point of the field of view. The signal produced by CHEOPS can be measured and a model of the gain/flat field as a function of the different environmental parameters will be built. The main *calibrations* to be made with the test bench are:

- Measure offset maps, dark maps, hot/defective pixel map, and measure their stability
- Measure the flat field of the instrument as a function of wavelength at a precision of 0.1%
- Measure the gain of the CCD in its flight configuration vs. environmental parameters

The main *validation tests* done with the test bench will be:

- Check PSF shape and dimensions across the possible field and the wavelength.
- Check that CHEOPS reaches the 20 ppm stability requirement?

III TEST BENCH DESIGN

The calibration will be performed using the CHEOPS flight model. CHEOPS will be enclosed in a Thermal Vacuum chamber (TVC) that will reproduce the flight conditions, in particular the temperature variations along an orbit. The test system has been designed to illuminate CHEOPS from the outside of the TV chamber. This has made the setup much less expensive and risky. However we have to cope with the fact that one cannot guarantee that the position and direction of the test beam remains stable with respect to the payload during the tests.

To put things simply, test system is a large collimator with different sources for the different calibrations. Essentially there are 2 instruments modes for the test system: a uniform illumination mode for the flat field

calibration and a single point source mode to simulate a star and make photometric tests. In addition, in the point source mode there are a tip-tilt tracking mechanism and a pupil tracking mechanism.

The most critical performance of this calibration system is the photometric stability of the beam it feeds into CHEOPS.

Optically the calibration system features

- a focal module where the point source creating the artificial star is located. This module is mounted on a Steward platform¹. A flat field source is also provided in the form of an integrating sphere
- a large off-axis 2540 mm focal length Ø457 mm parabolic collimator to send the point-like artificial star to infinity
- a large folding flat mounted on a precision tip-tilt stage to explore the full field of view
- a large window to separate the bench itself in ambient air from CHEOPS sitting in a space environment simulator. Technically, this window is not part of the bench but we include it here because it is part of the calibration system performance budget.

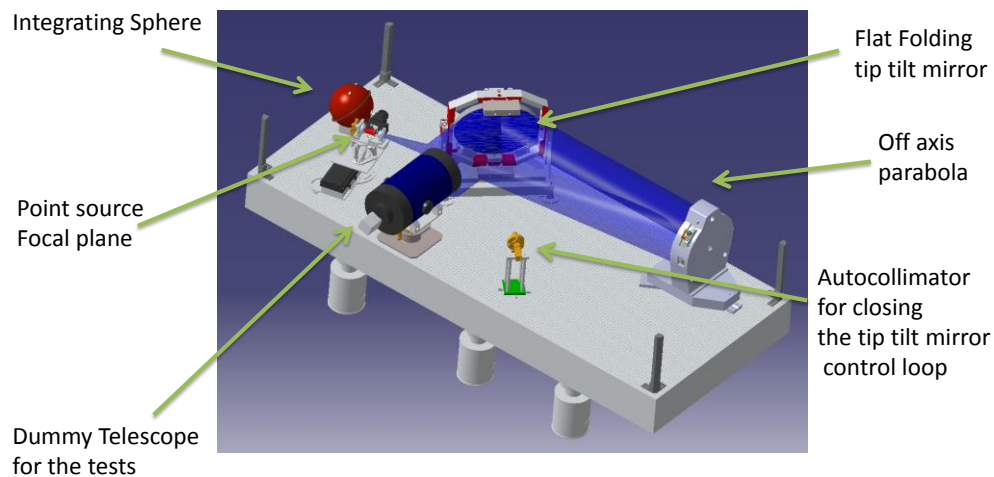

Fig 2. Side view of the calibration bench with the optical beam rendered in blue. The configuration shown is the configuration used for the validation where a commercial telescope (in blue) simulates CHEOPS. The yellow device is a digital auto-collimator used to servo the folding flat in position.

The focal module

This module is made of two elements. Only one can be at the collimator focus at any time.

- A flat-field source in the form of a high grade integrating sphere with a high $\text{Ø}_{\text{ext}}/\text{Ø}_{\text{port}}$ ratio to insure good center-to-edge flatness
- A point-source unit. This unit incorporates a number of functions
 - An artificial star in the form of a single mode fiber simulating the object of interest in the field.
 - 4 additional fibers in the focal plane that are used for the pupil tracking (see figure 3)
 - An apodizer which role is to transform the Gaussian-like energy distribution in the beam coming out of the star fiber into a flat energy distribution as expected in flight. See section "optical budgets".
 - A pierced mirror reflecting part on the light from the artificial star into a sensing fiber. See section "super stable source".
 - A mask featuring 4 fiducials used to maintain pupil centration.

More details on this design can be found in [5]

¹ A steward platform is a 6-degrees of freedom mount, often referred to as an hexapod

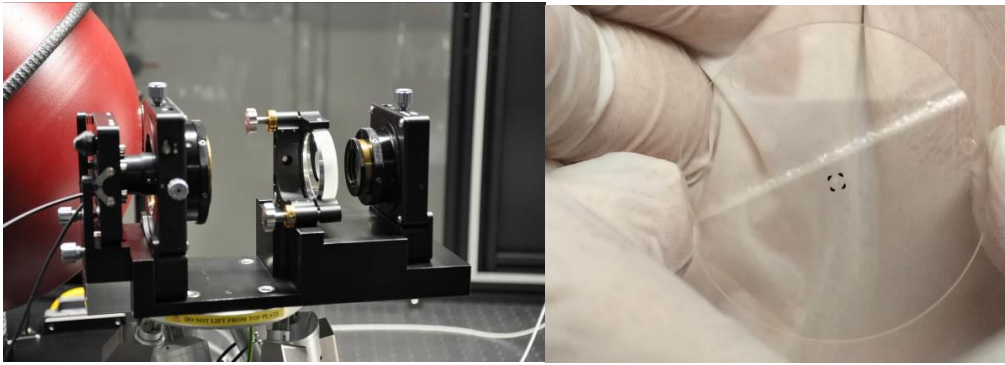

Fig 3. On the left, Side view of the focal plane module. On the right the mask, that allow for the masking of halves pupil on the 4 lateral sources.

IV FLAT FIELDING

One of the challenge of the CHEOPS calibration phase is to produce a good flat field of the instrument that will allow to mitigate the satellite jitter. The specification is to reach 0.1% precision for this flat field. This is achieved using an integrating sphere to produce a uniform illumination. In addition to classical white light flat fields, we are going to measure “coloured flat fields” in contiguous 16nm bins. Based on this data set it shall be possible to reconstruct the best flat fields matched to the spectral type of each star observed.

To check that the uniformity of the Integrating sphere was sufficient for our needs we have started to measure it by scanning the output port with a photometer and found that it is not as uniform as we need (see figure 4). To mitigate this we will model the actual field distribution and use this model when reducing the CHEOPS calibration data. That in turn has forced us to design a reticule that we can fit over the output port to reference our model to a well-defined location on the port.

It has been checked that the rest of the test bench elements will not affect the flatness of the field. Neither contamination nor aberrations nor coatings non-uniformities have will alter the beam uniformity to a significant amount.

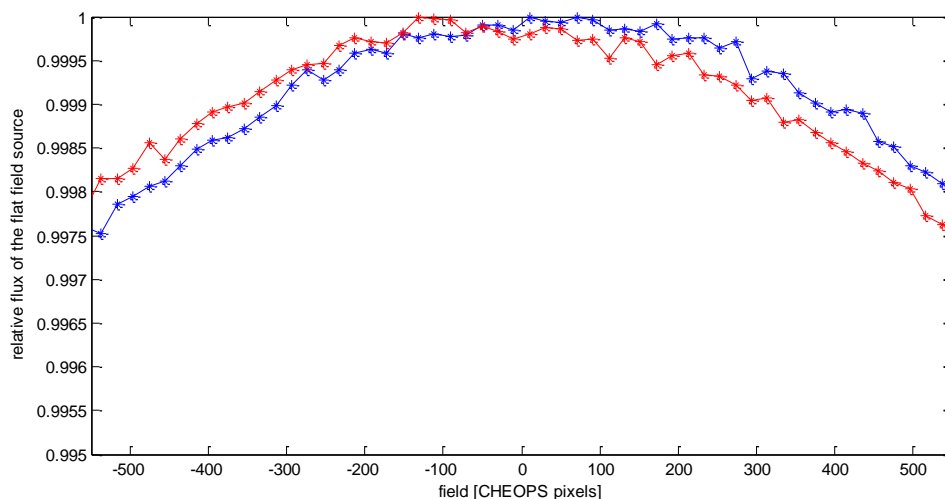

Fig 4. Vertical and horizontal scans of the flat field Integrating sphere in white light.

IV PUPIL STABILIZATION

The stability of optical power as measured by CHEOPS is determined not only by the stability of our calibration light source (see next section), but also by the stability of the optical coupling between the calibration beam and CHEOPS. It turns out that if there is a beam shift between bench and CHEOPS and if the field in the bench pupil is not homogenous variation of this coupling happens. This variation will depend on:

- Optical field homogeneity in the beam

- The amount of beam shift on the bench surfaces and between the bench and the payload
- The amount of beam shift on the vacuum enclosure entrance window and the homogeneity of its transmission
- The possible focus variation of the beam which will change the density of the field in the pupil even with a perfect source and no beam shift

Because of the need to have an unresolved point source to simulate the star, we are using a monomode fiber. Therefore, the field distribution across the pupil will be close to Gaussian. This strongly varying distribution creates a high photometric sensitivity to relative motions that is unacceptable. Thus an apodizer has been introduced in the beam.

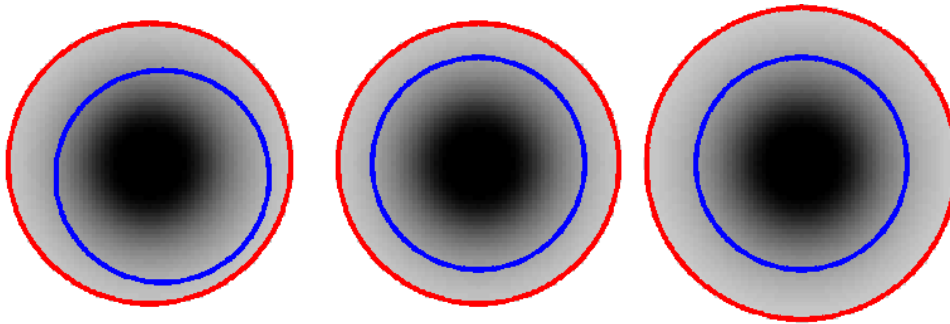

Figure 5. Diagrams underlining the pupil homogeneity problem: The calibration system pupil is represented in red and its irradiance in is represented in gray tones. The CHEOPS pupil is represented in blue. The optical power measured by CHEOPS is the integral of the optical field entering its pupil. If there is a motion between the two pupils (L/h), the integral of the field in the blue pupil will vary and so will the photometric signal. If the beam of the calibration system gets defocused due to temperature variations, then its beam will expand or contract coupling less, respectively more light into CHEOPS.

As described in [5] this apodizer is optimized in white light assuming the sensitivity of the whole optical chain from the source to the detector. The homogeneity obtained is not enough to ensure the stability of the flux thus it is necessary to have a pupil stabilization mechanism.

To this purpose a set of 4 fiducial stars placed at 90° on a small circle around the reference star have been added. A mask is placed closely placed in front of these fiducials. The purpose of this mask is to make the pupil illumination of this fiducials as contrasted across the pupil as possible. So if the focal plane is tilted, it shifts the energy distribution across the pupil (Fig 6, center), this shift is going to be maximal for the half-moons. One of the half-moons will see a flux increase while to opposite one will see a decrease. Keeping the photometric ratio constant between the up and down, respectively left and right, half-moons forces the bench and CHEOPS pupil to be co-aligned. Since only tilts are involved, the image of the center star and the fiducials stay put in the CHEOPS focal plane.

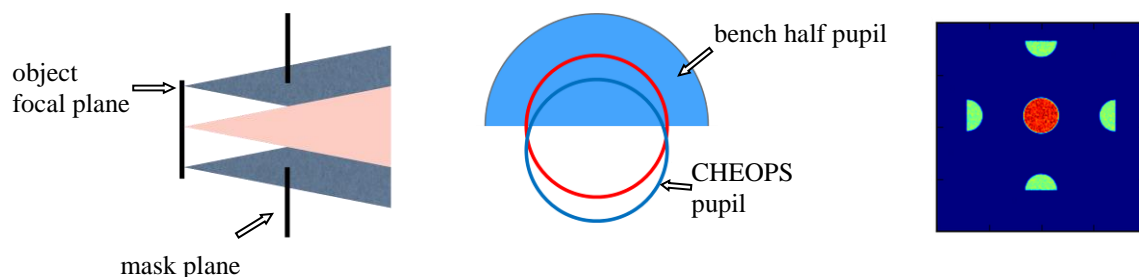

Figure 6: Schematic diagram of the pupil centering scheme. L/h figure: On the focal plane the central "star" emits an unobstructed beam. Two fiducial stars emit beam that are partially obstructed by a mask. Center figure: View of top fiducial beam at the pupil level. Because of the mask, the fiducial pupil is not uniformly illuminated. If the relative position between the calibration system pupil and the CHEOPS pupil changes, the amount to light that is coupled between the two systems will change. R/h figure: image of the central star and the 4 fiducials in the CHEOPS focal plane. If the relative position between the calibration system pupil and the CHEOPS pupil changes vertically, the ratio between the top half-moon and the bottom half moon will change and this ratio is used as feedback in a control loop

To implement the pupil centering scheme, the focal plane module is mounted on a hexapod. We are using two degrees of freedom (DOF) to rotate the focal plane around the fiber tip. We are using another two DOF's to move the focal plane sideways to simulate the satellite pointing wobble and a last DOF to move the source along the optical axis to adjust the focus.

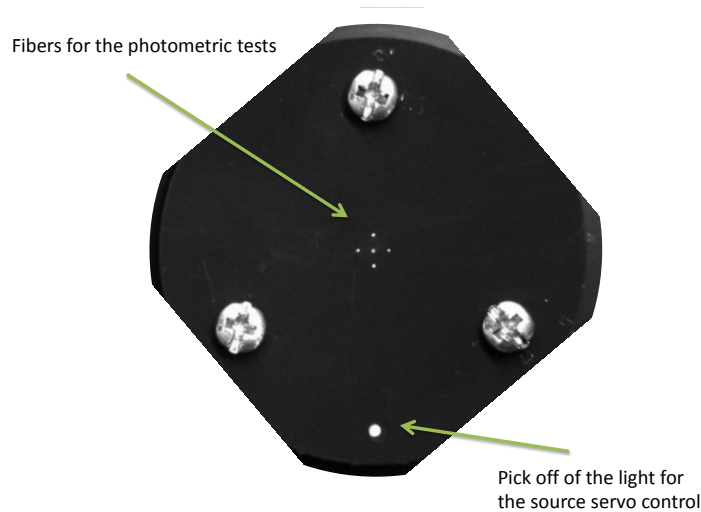

Figure 7. The picture shows the focal plane ferrule with the central star and the four fiducials. The dot at the bottom is the fiber collecting the light from the pick-off mirror for the feedback of the super stable source. The screws are holding the anti-reflection mask needed to control ghosts.

V SUPER STABLE SOURCE

For CHEOPS calibration system, we have chosen to use an LDLS [7] as primary source because its 10'000K color temperature offers both a flat spectrum across the visible and a high radiance that allows a sizable amount of power to be coupled even in a monomode fiber. We have measured that this lamp has a luminous power output variation in the 1-3% p2v range, i.e. 10'000 to 30'000ppm over 6 hours which is the duration over which the CHEOPS performance is specified. It is obvious that a lamp like that cannot be used without having its flux stabilized.

For this reason, the Observatory of Geneva has developed a luminous power control system that transforms the LDLS in what we call Super Stable Source [6]. Over the course of several hours the source is stable to a couple of ppm (figure 8).

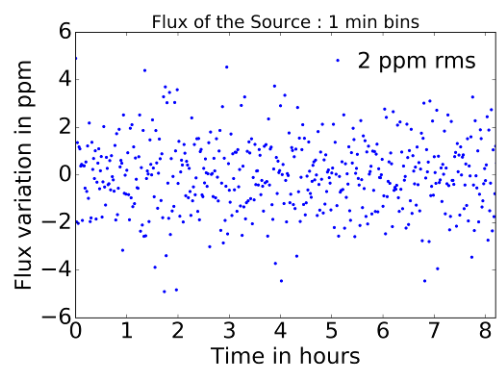

Figure 8. (Left) View of the super Stable source. (Right): performance of this source with stabilization. Stability is about 2ppm RMS when signal averaged in 1min bins

VI MEASURED PERFORMANCES

The calibration system has been accepted in the summer of 2016 and moved to the CHEOPS integration facility at the University of Bern. Here are some of the performances measured at this stage:

The wavefront of the collimator measured after alignment <90 nm rms. This does not include the apodizer and the necessary optical density, but is compliant with our 150 nm wavefront error budget.

The focal plane image is:

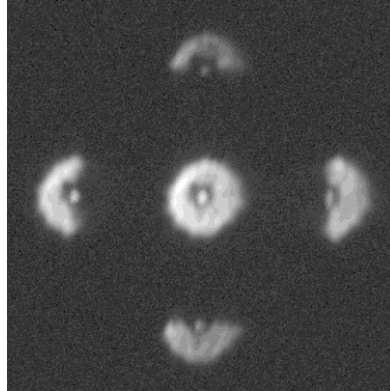

Figure 9 image of the focal plane in the star photometric mode. The central PSF is artificial star used as a photometric reference, while the 4 other PSFs are used to measure the pupil movements as explained above.

Tip-Tilt mirror servo

The flat folding mirror is mounted in a custom tip and tilt mount high resolution actuators. In combination with a high resolution autocollimator (Newport LDS-Vector) measuring its direction with a resolution of 0.1 microradians we build a PC-based servo system that has a typical time constant of 1 second and a precision of 0.1 microradian

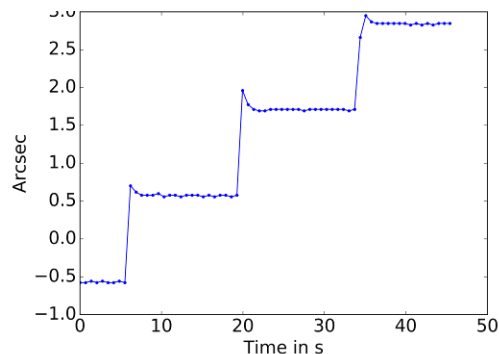
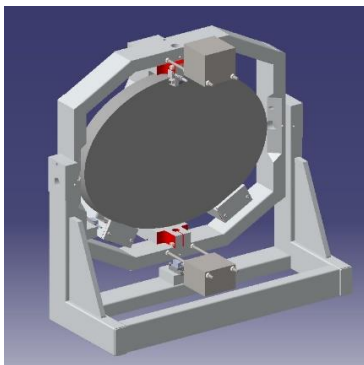

Figure 10 Performance of the tip-tilt mount in its control loop mode

Tip-tilt control with the payload in the loop

In order to compensate for the thermomechanical movement of CHEOPS we are using the payload images to directly measure the relative tip-tilt between our calibration beam and CHEOPS inside its vacuum tank. The open-loop performances achieved are below 0.3 arcsec even when the satellite wobble is simulated by the hexapod holding the artificial star. On figure 12 one can see the sensitivity of the measurement of the pupil position and on Figure 13 one can see the close loop operations of this system.

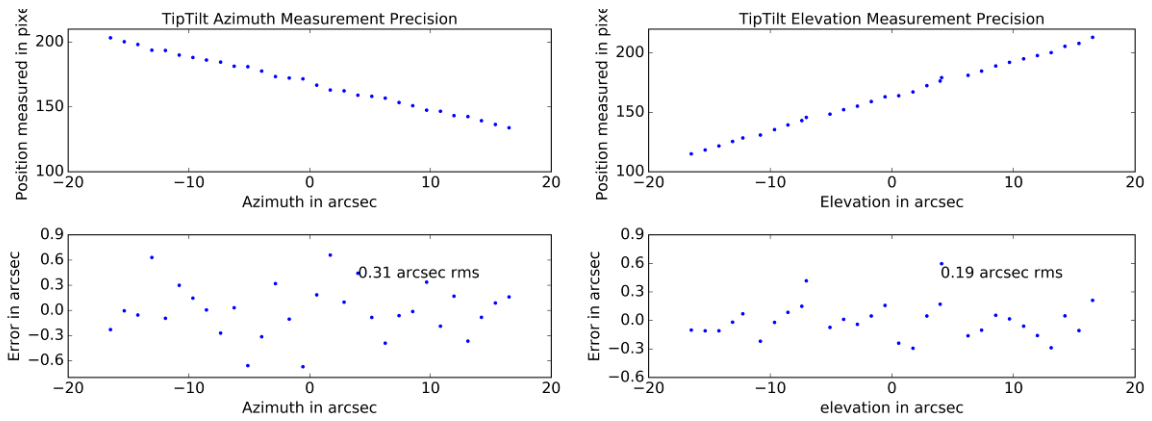

Figure 11 Performance of the tip-tilt measured using the dummy CHEOPS. Measurements performed in presence of the simulated satellite wobble. The field has been scanned using the Tip-Tilt mirror. The achieved precision is around 0.3 arcsec

Pupil position control with the payload in the loop

Pupil tracking is working using differential photometry in the focal plane. If one builds a signal using the top vs. bottom half-moons flux and the left vs. right flux one have a signal proportional to the pupil position. On figure 12 one can see the sensitivity of the measurement of the pupil position and on Figure 13 one can see the close loop operations of this system.

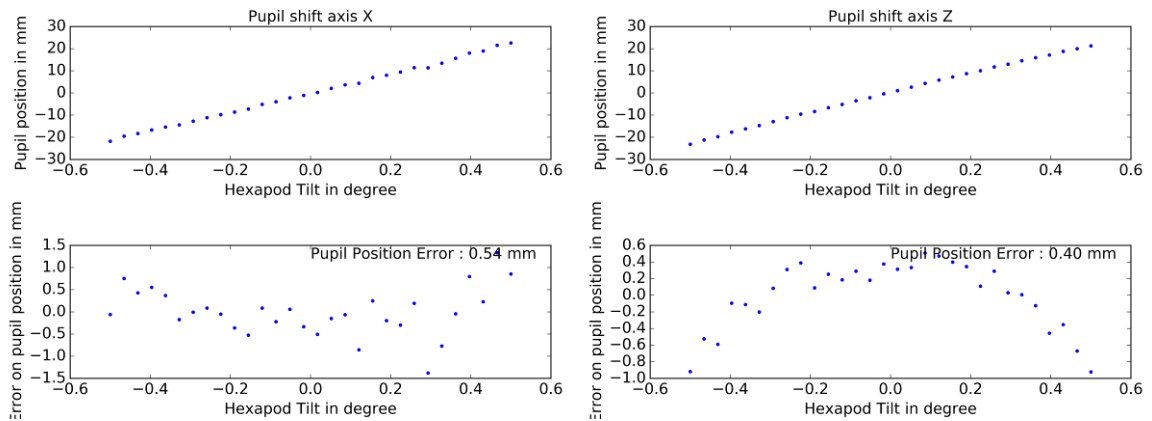

Figure 12 Sensitivity of the pupil tracking measurement. The hexapod holding the focal plane is used to scan across the pupil by rotating the tip of the fiber forming the artificial star. The precision achieved is better than 0.5 mm/ over the 300 mm pupil (which is fine to ensure the performances).

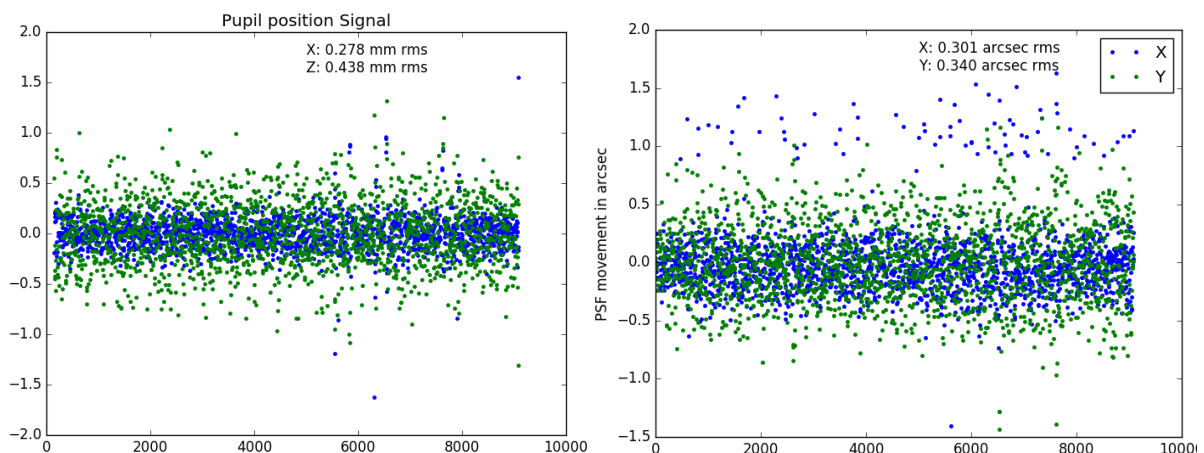

Figure 13 Results of the Close loop stabilization of the pupil and the tip-tilt of the bench using a dummy telescope. On the left the pupil signal, on the right the tiptilt signal. X-axis unit is time in [s]

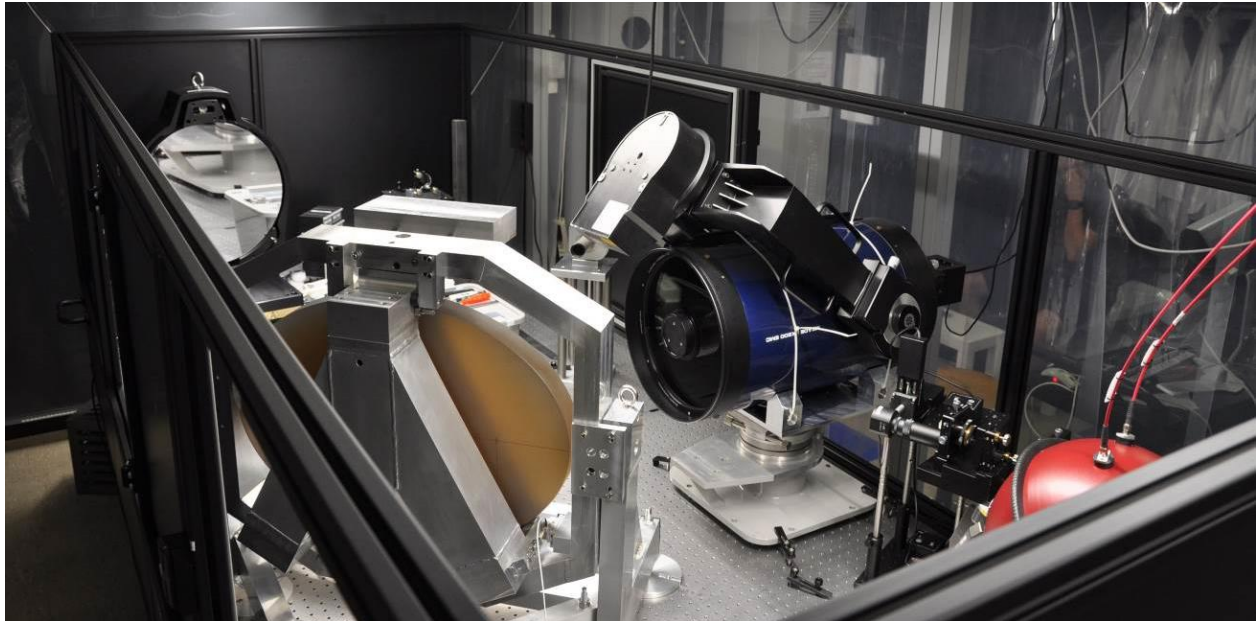

Figure 14. The CHEOPS calibration bench. The commercial telescope (in blue) simulates CHEOPS. In operation the cover is fully closed.

VII CONCLUSION

We have assembled and tested a complex opto-electro-mechanical setup capable of calibrating and validating the performances of the CHEOPS payload. The calibration system is now complete; the performances are in line with our expectations and with the performance budget. The system is now be relocated to the CHEOPS payload integration facilities and will serve to fully calibrate it in the course of 2017. To our knowledge it is the first time the end-to-end verification of the photometric performance of a photometric transit satellite is attempted.

REFERENCES

- [1] Benz W. and the Cheops team, CHEOPS: scientific objectives, mission concept and challenges for the scientific community”, the 4S Symposium 2014.
- [2] T. Beck, L. Gambicorti, Ch. Broeg, A. Fortier, D. Piazza, V. Cessa, D. Ehrenreich, D. Magrin, J-Y Plesseria, G. Peter, I. Pagano, M. Steller, Z. Kovacs, R. Ragazzoni, F. Wildi, W. Benz, The CHEOPS (CHARacterizing ExOPlanets Satellite) mission: telescope optical design, development status and main technical and programmatic challenges, International Conference on Space Optics (ICSO 2016)
- [3] A. Deline, F. Wildi, M. Sordet, B. Chazelas, The testing and characterization of the CHEOPS CCDs, International Conference on Space Optics (ICSO 2016)
- [4] V. Cessa, T. Beck, W. Benz, C. Broeg, D. Ehrenreich, A. Fortier, G. Peter, D. Magrin, I. Pagano, J.-Y. Plesseria, M. Steller, J. Szoke, N. Thomas, R. Ragazzoni, F. Wildi & the CHEOPS Team. "CHEOPS: A space telescope for ultra-high precision photometry of exoplanet transits", International Conference on Space Optics (ICSO 2014).
- [5] F. Wildi, B. Chazelas, A. Deline, M. Sordet, M. Sarajlic, “The CHEOPS' instrument On-Ground calibration system. ”, Techniques and Instrumentation for Detection of Exoplanets VII, SPIE 9605-45 (2015).
- [6] F. Wildi, B. Chazelas, A Deline. "A white super stable source for the metrology of astronomical photometers", SPIE 9605-63 (San Diego 2015).
- [7] <http://www.energetiq.com/DataSheets/EQ99XFC-Data-Sheet.pdf>.
- [8] T. Beck et al, “CHEOPS: status summary of the instrument development”, SPIE, 9904-75
- [9] N. Rando et al ,”ESA CHEOPS mission: development status, SPIE 9904-74”, SPIE, 9904-75