

# Cours de techniques et méthodes de l'astronomie moderne

## *Spectroscopie*

F. Pepe

Observatoire de l'Université Genève

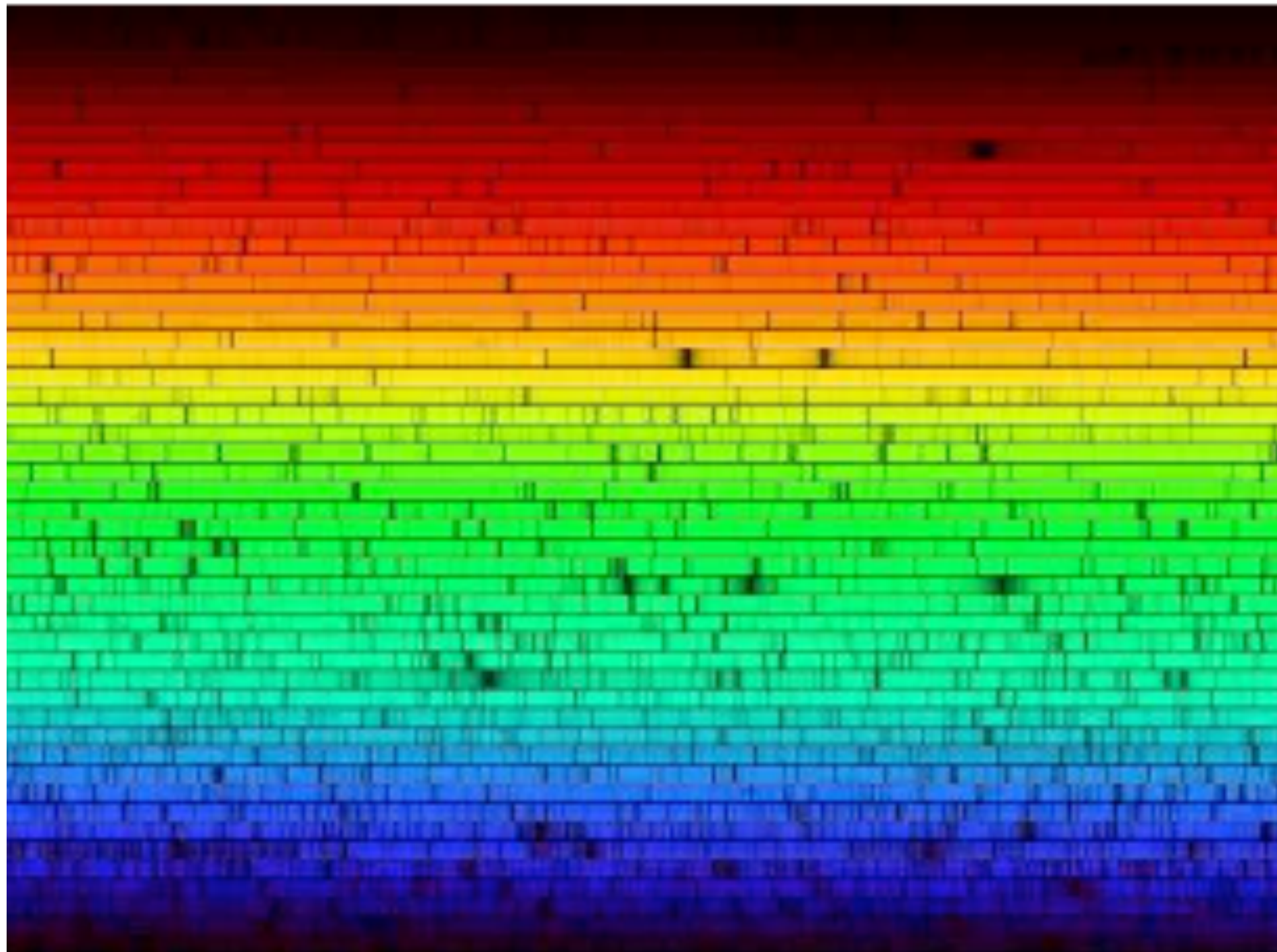

# Course outline

- PART 1 - Principles of spectroscopy
  - Fundamental parameters
  - Overview of spectrometry methods
- PART 2 - 'Modern' spectrographs
  - 'Simple' spectroimager
    - FORS
  - Echelle spectrographs
    - UVES
    - CRIRES
- PART 3 - Spectroscopy on the VLTs
  - Multi-Object spectrographs (MOS) and Integral-Field Units (IFU) and spectro-imagers
    - Giraffe
    - VIMOS
    - Sinfoni
  - Future instruments
    - X-shooter
    - MUSE
    - ESPRESSO

# The observables

Propagation of light wave from **stable** source at infinity:

$$\vec{E}(\vec{x}, t) = \vec{A} \cdot e^{-i(\vec{k}\vec{x} - \omega \cdot t)}$$

which is a solution of **wave equations** if:

$c_n$  is the speed of light in a medium with refractive index  $n = n(k)$

$$c_n = \frac{\omega}{k}, \text{ where } k = |\vec{k}|$$

Independent observables are:

$\vec{A}$  = Amplitude of electric field

$(k_x, k_y)$  = Direction vector projected on sky

$\omega$  = Frequency or  $k$  = Wave vector

The distance between two spatial maxima of the light wave in a given medium and at fixed  $t$  is called wavelength and results to be:

$$\lambda_n = \frac{2\pi}{n(k) \cdot k}$$

# The observables

Astronomical spectroscopy aims at measuring:

$$\vec{A}(\nu, (k_x, k_y)) \quad \text{or} \quad \vec{A}(\lambda, (k_x, k_y))$$

At optical wavelength  $\nu = \omega/2\pi$  is  $10^{15}$  Hz, thus too fast to be resolved by detectors. The observable becomes the (surface) brightness or **specific intensity**  $I_\nu$  or  $I_\lambda$ :

$$I_\nu(k_x, k_y) = \overline{|\vec{E}_{\nu, \lambda}(t, \vec{x}_{obs})|^2} = \frac{1}{2} |\vec{A}(\nu, (k_x, k_y))|^2 \quad [\text{W m}^{-2} \text{ sterad}^{-1} \text{ Hz}^{-1}]$$

$$\text{or} \quad I_\lambda(k_x, k_y) = \frac{1}{2} |\vec{A}(\lambda, (k_x, k_y))|^2 \quad [\text{W m}^{-2} \text{ sterad}^{-1} \mu\text{m}^{-1}]$$

# The observables

If we integrate the surface brightness over a given source or sky aperture, we get the spectral **flux density**  $F_\nu$  or  $F_\lambda$  at a given light frequency or wavelength:

$$F_\nu = F(\nu) = \int S(\nu, (k_x, k_y)) \cdot \cos \Theta \cdot d\Omega \cong \int S(\nu, (k_x, k_y)) \cdot d\Omega$$

$$F_\lambda = F(\lambda) = \int S(\lambda, (k_x, k_y)) \cdot \cos \Theta \cdot d\Omega \cong \int S(\lambda, (k_x, k_y)) \cdot d\Omega$$

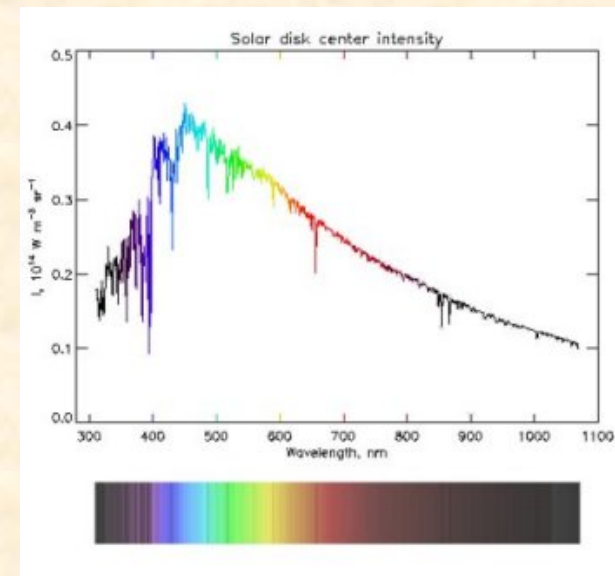
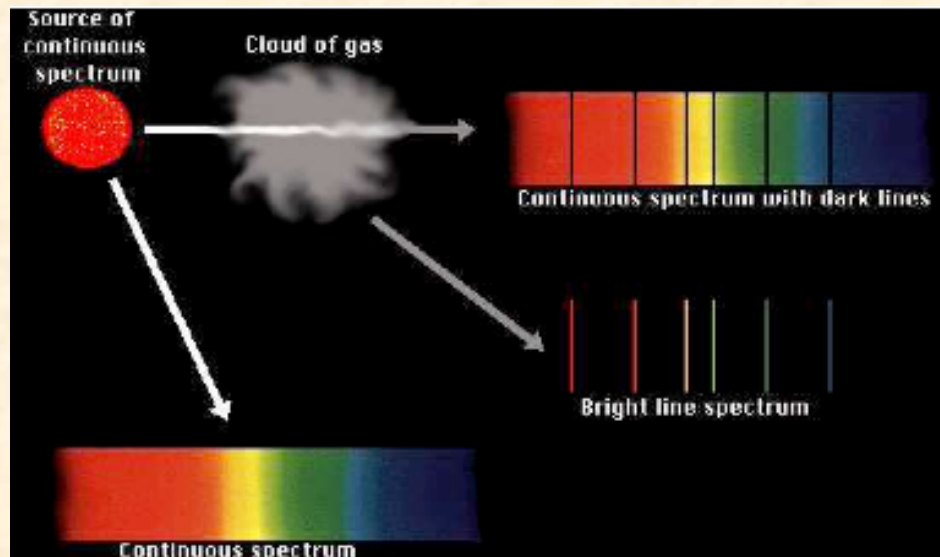

# The observables

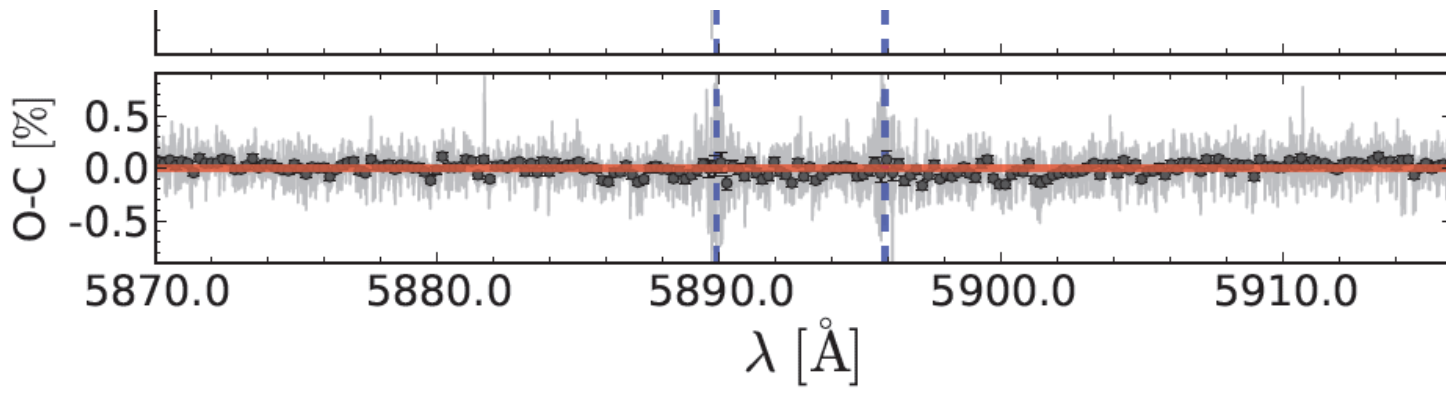
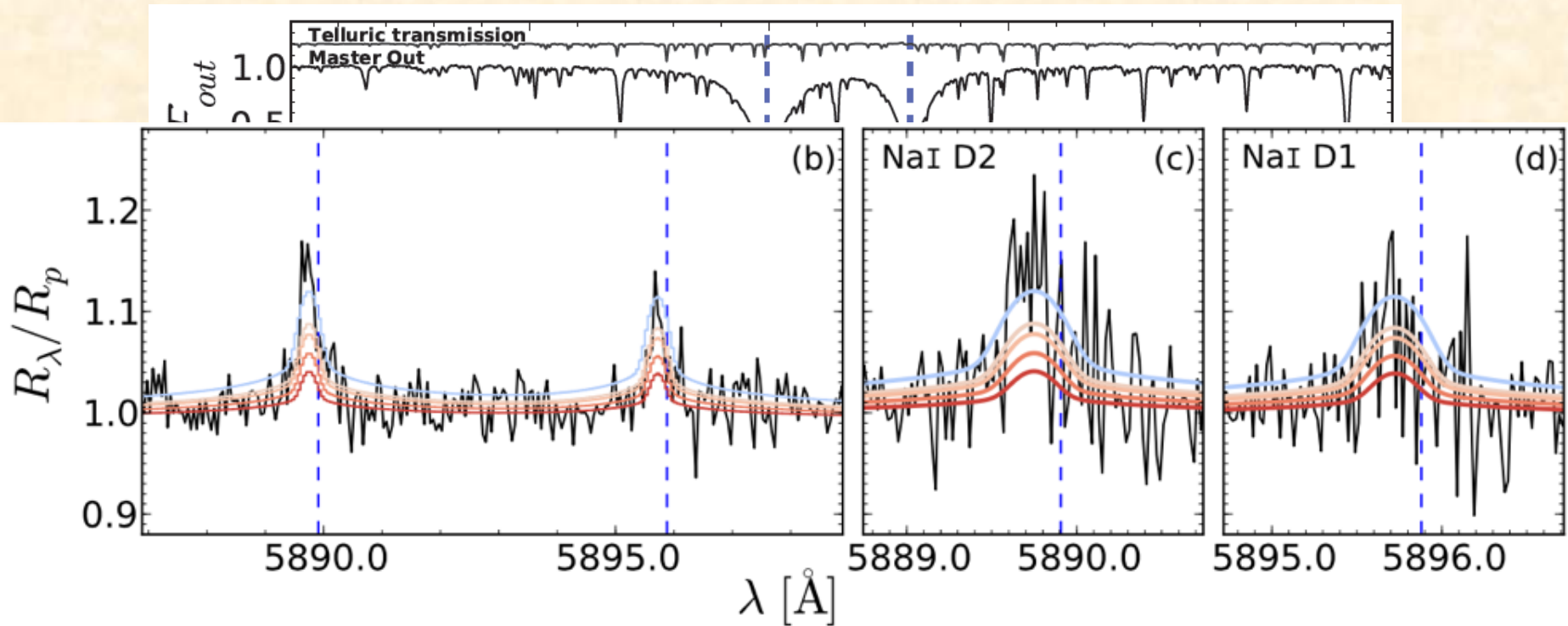

# Wavelength or frequency?

Frequency ( $\nu$ ,  $\omega$ ), associated to time-evolution of E-field

- Fixed location (detect oscillation amplitude as a function of time)
- Need for precise clock (time metric)
- Need for time resolution (or other tricks, e.g. heterodyne detection)

Wavelength ( $\lambda$ ,  $k$ ), represents light propagation in space

- Fixed time (project wave into physical space or **spatially** separate various spectral components)
- Depends on medium ->
- Need for precise metrology (space metric) or calibration

$$\vec{E}(\vec{x}, t) = \vec{A} \cdot e^{-i(\vec{k}\vec{x} - \omega \cdot t)}$$



# Filter spectrometer

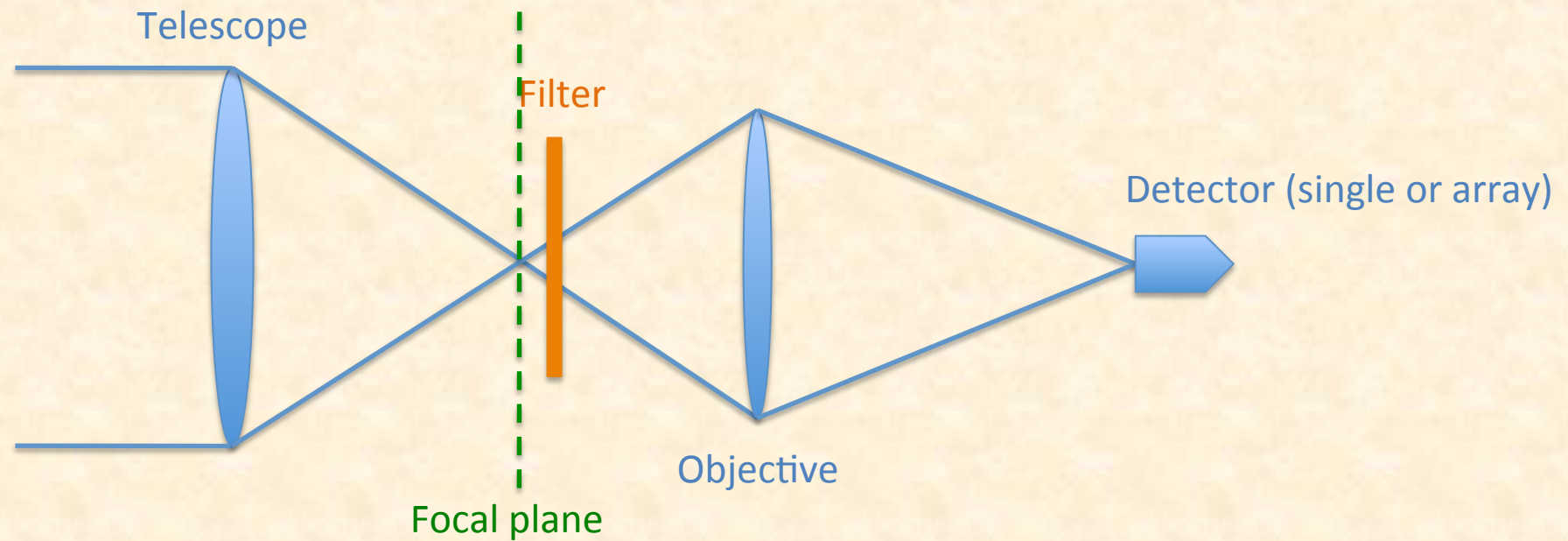

# Filter spectrometer

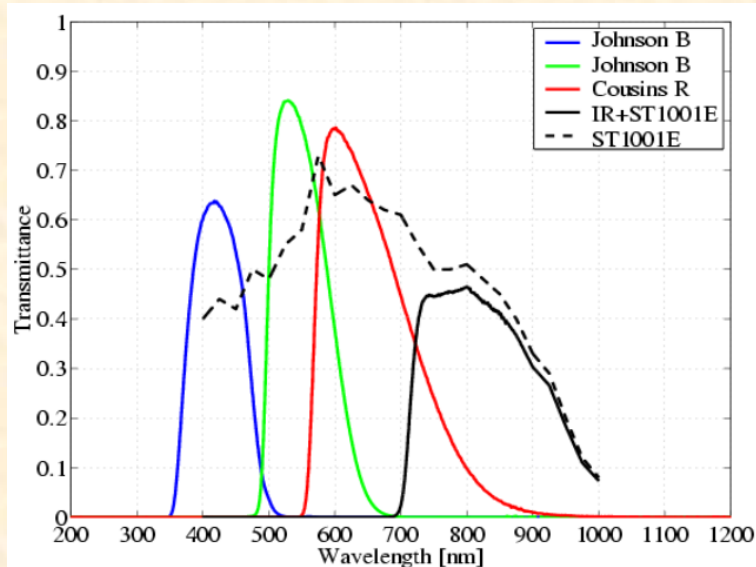

- Detector records  $I_\lambda$  for a given filter with transmittance  $t_c$ , central wavelength  $\lambda_c$ , and band width  $\Delta\lambda$
- $t_c$ ,  $\Delta\lambda$  and  $\lambda_c$  need to be calibrated on standard sources
- Appropriate for broad-band spectra
- Only one channel per measurement (unless dichroics are used)

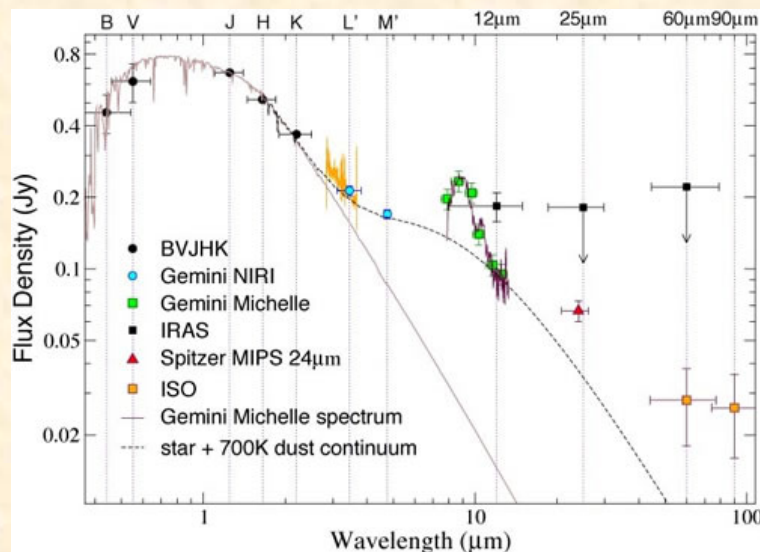

# Filter spectrometer

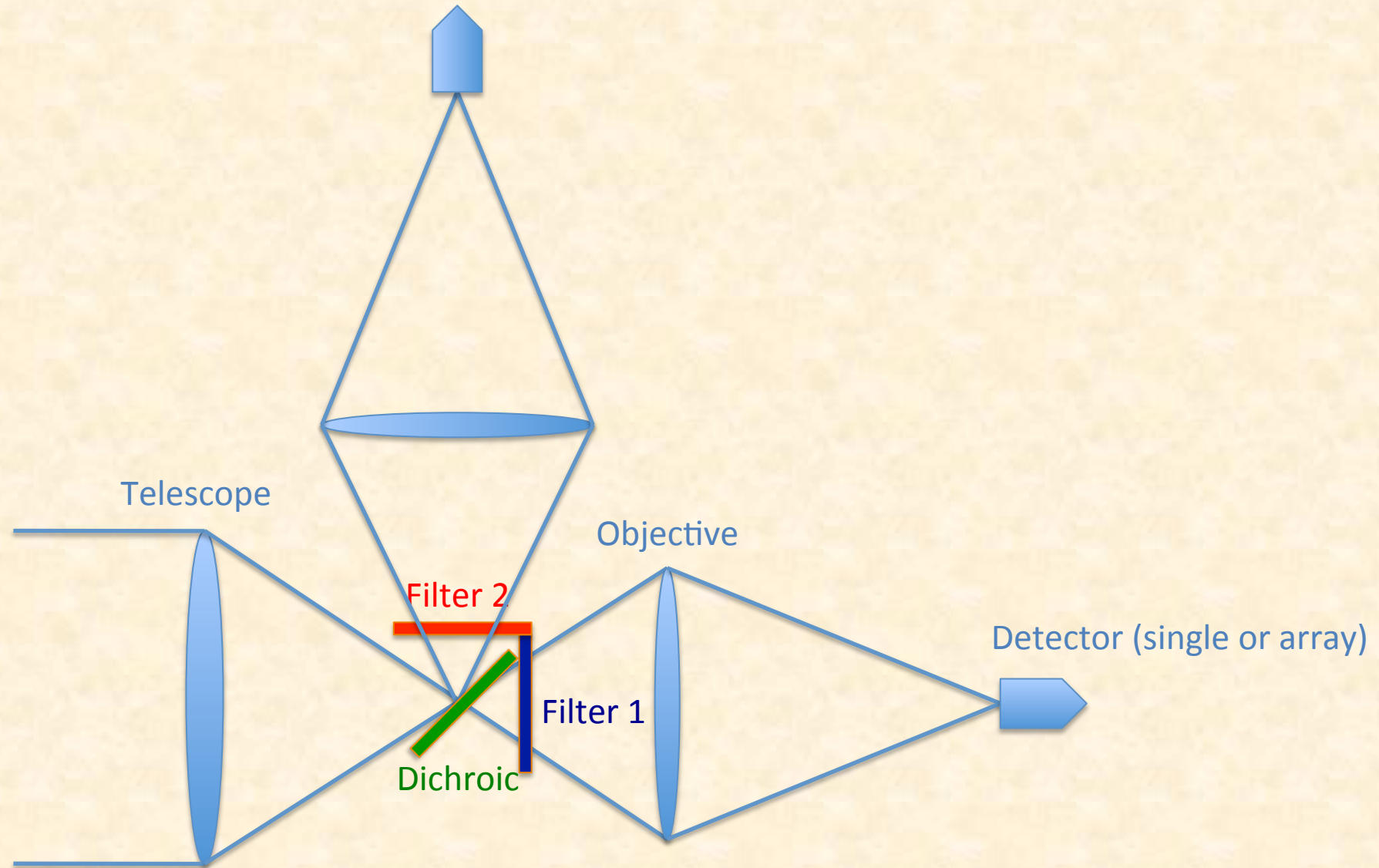

# Fabry-Pérot spectrometer

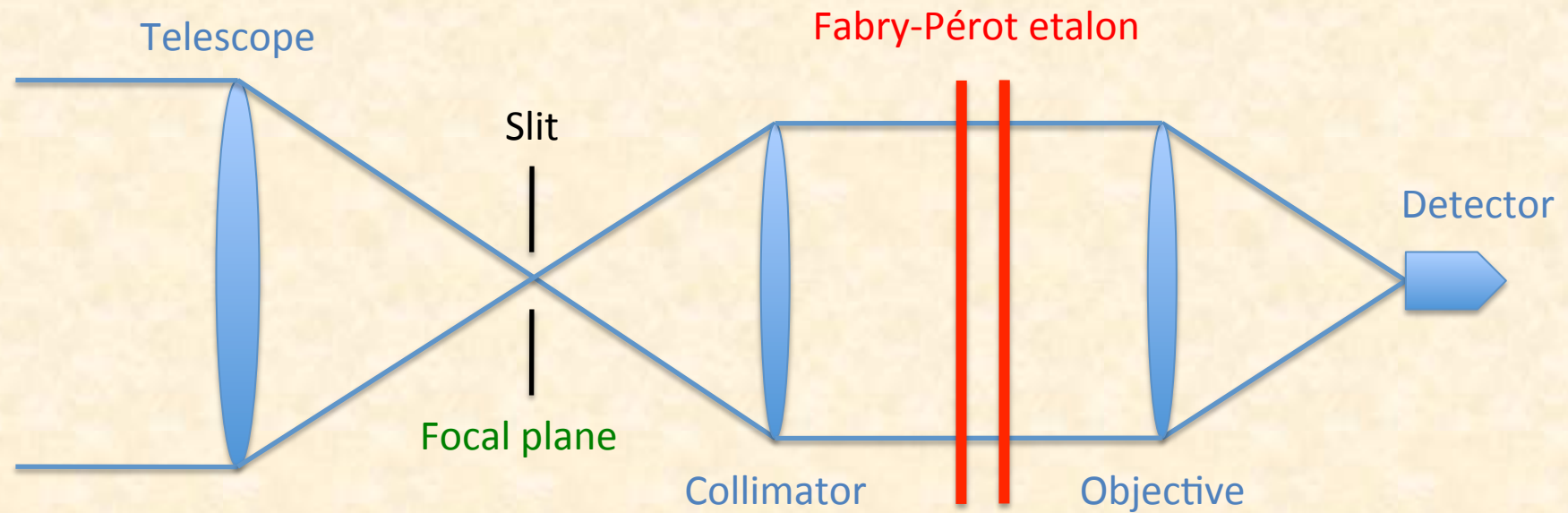

# Fabry-Pérot spectrometer

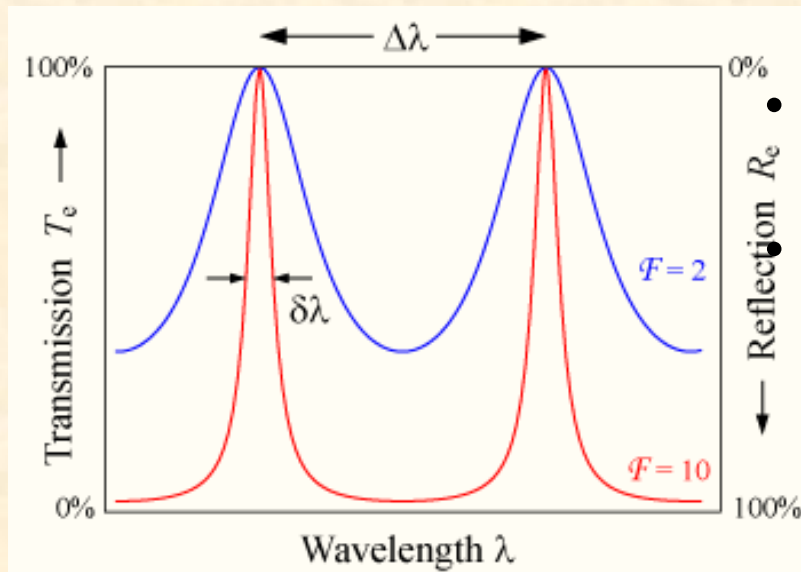
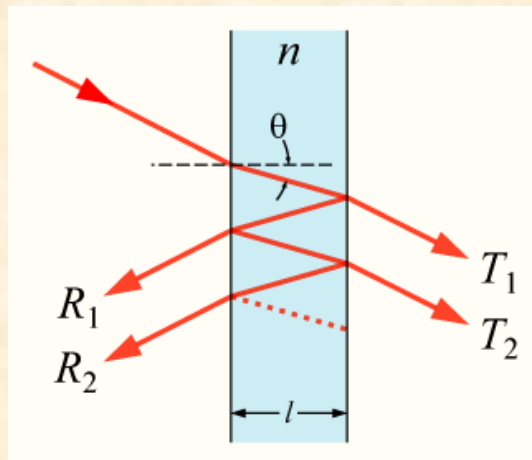

- Similar to filter spectrometer, but spacing can be made tunable
- Detector records  $I(\lambda)$  as a function of the transmitted wavelength  $m\lambda=2l$ , where  $m$  is an integer and enumerates the transmitted order.

- Only one spectral channel per measurement

- Transmittance and wavelength must be calibrated.

Allows high spectral resolution, if the finesse  $F$  or the order  $m$  is high. In the latter case, a pre-filtering is required to select only one wavelength (order-selection).

# Fabry-Pérot spectrometer

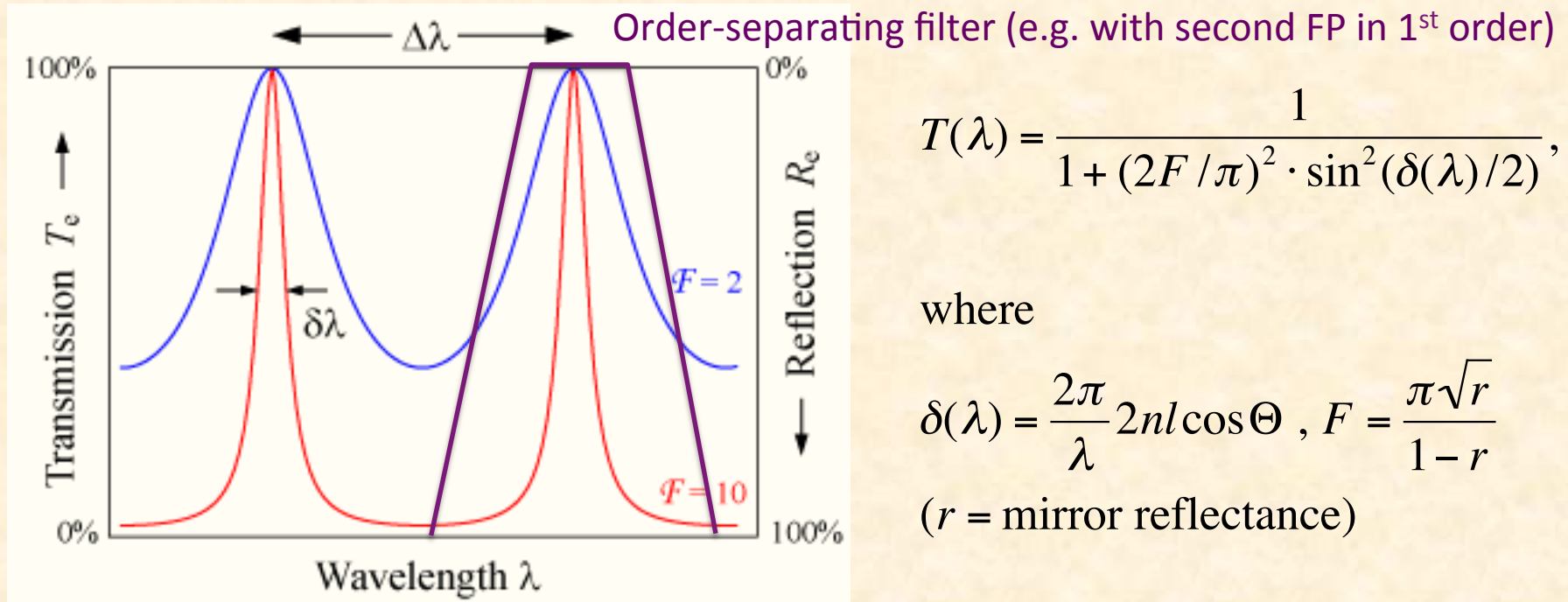

$$T(\lambda) = \frac{1}{1 + (2F/\pi)^2 \cdot \sin^2(\delta(\lambda)/2)},$$

where

$$\delta(\lambda) = \frac{2\pi}{\lambda} 2nl \cos \Theta, \quad F = \frac{\pi\sqrt{r}}{1-r}$$

( $r$  = mirror reflectance)

Transmitted wavelength:  $\lambda_m = 2nl \cos \Theta / m$

Order separation:  $\Delta\lambda = \lambda_{m-1} - \lambda_m \approx 2nl \cos \Theta / m^2$

Finesse:  $F = \Delta\lambda / \delta\lambda$

Spectral resolution:  $R := \frac{\lambda}{\delta\lambda} = m \cdot F$

# Fabry-Pérot spectrometer

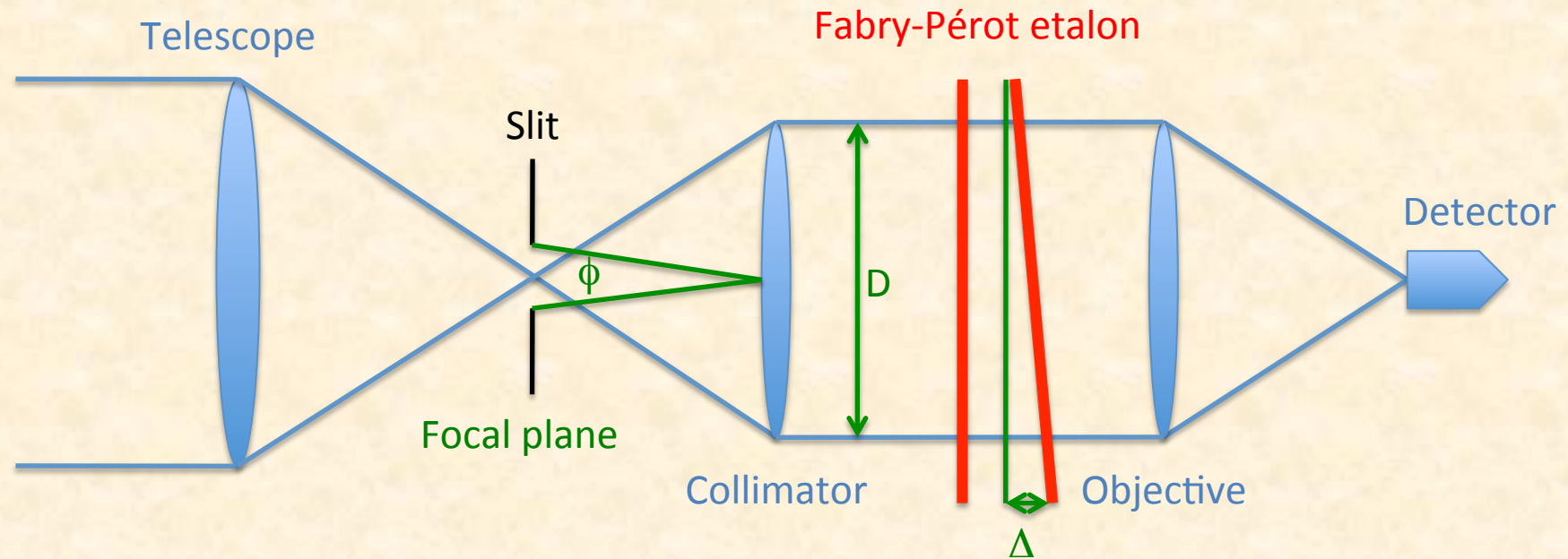

Real Fabry-Pérot:

$$T(\lambda) = \frac{1}{1 + (2F_E / \pi)^2 \cdot \sin^2(\delta(\lambda)/2)},$$

where  $\frac{1}{F_E^2} = \frac{1}{F_R^2} + \frac{1}{F_D^2} + \frac{1}{F_P^2} + \frac{1}{F_\phi^2}$

$$F_R = \frac{\pi \cdot \sqrt{r}}{1 - r}, \quad \text{reflectance finesse}$$

$$F_D = \lambda / \delta / \sqrt{2}, \quad \text{defect finesse } (\delta = \text{defect rms})$$

$$F_P = \lambda / \Delta / 2, \quad \text{parallism finesse}$$

$$F_\phi = \frac{4\lambda}{\phi^2 l}, \quad \text{aperture finesse}$$

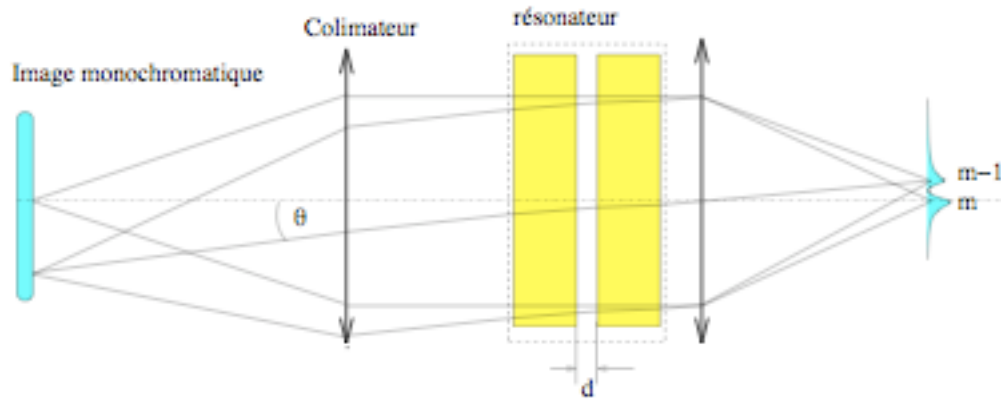

Example of aperture fine

Transmitted wavelength is unique only for given angle  $\theta$

If slit is too wide, the aperture (angle cone) is enlarged and the range of transmitted wavelength increased.

The 'contrast' is reduced, thus the finesse and the spectral resolution

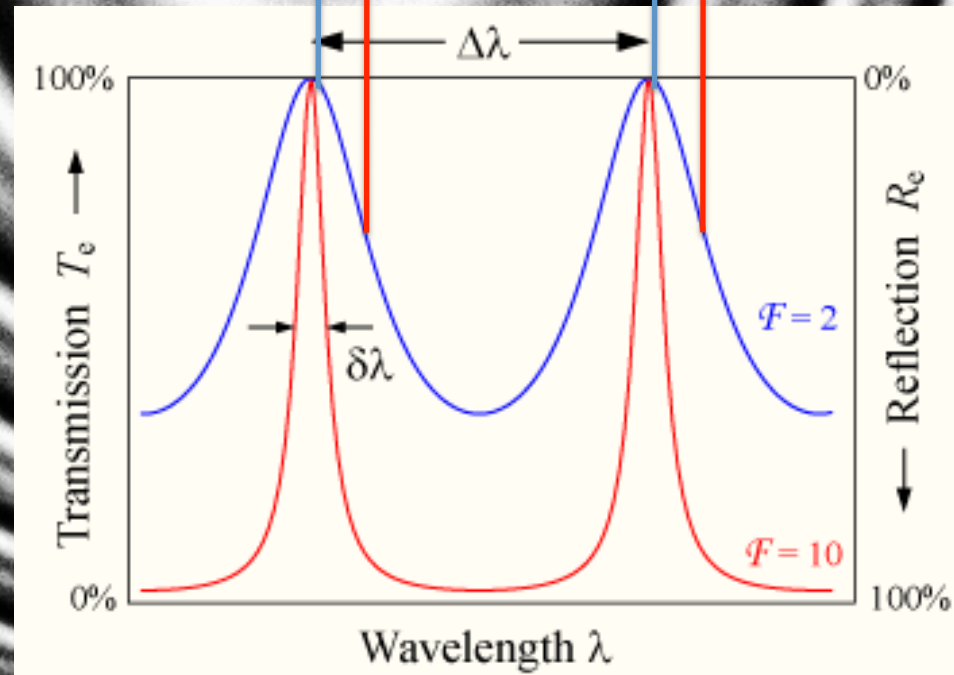



# General spectrograph layout

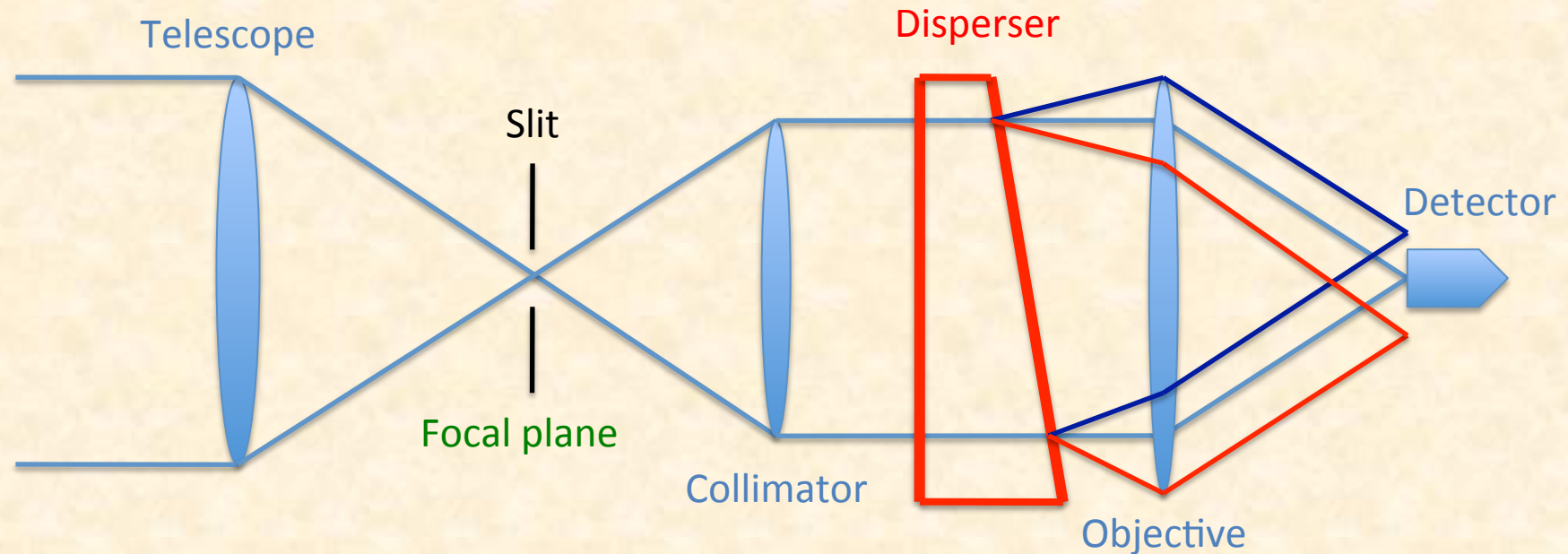

Single detector -> monochromator (may be used with movable part to scan over wavelengths)

Array detector -> spectrograph with  $N$  wavelength channels ( $N$  = number of detectors or pixels)

# Dispersers

The disperser separates the wavelengths in angular direction. To avoid angular mixing, the beam is collimated. The disperser is characterized by its angular dispersion:

$$D = \frac{\partial \beta}{\partial \lambda}$$

where  $\beta$  is the deviation angle from the un-dispersed direction

# The prism

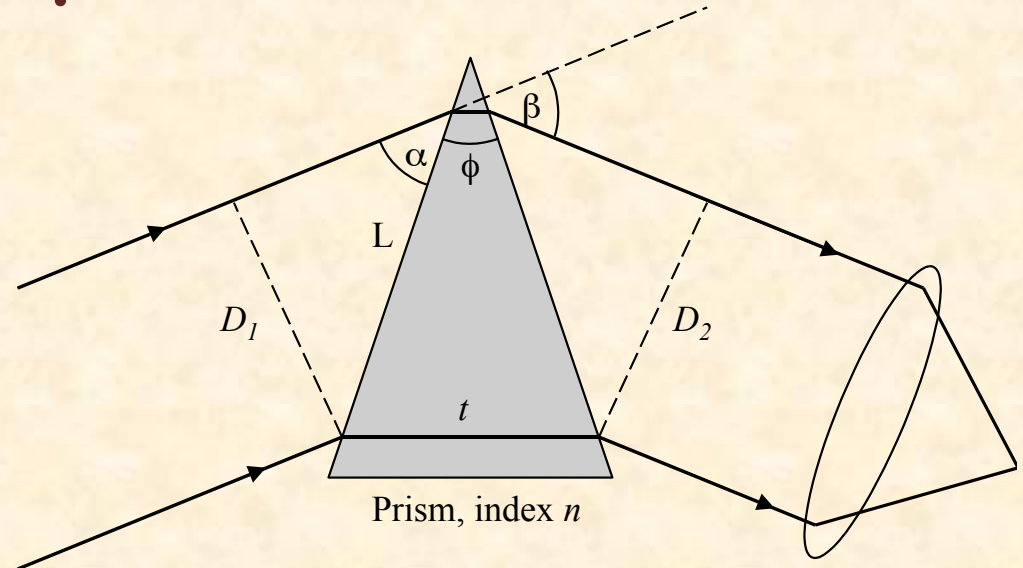
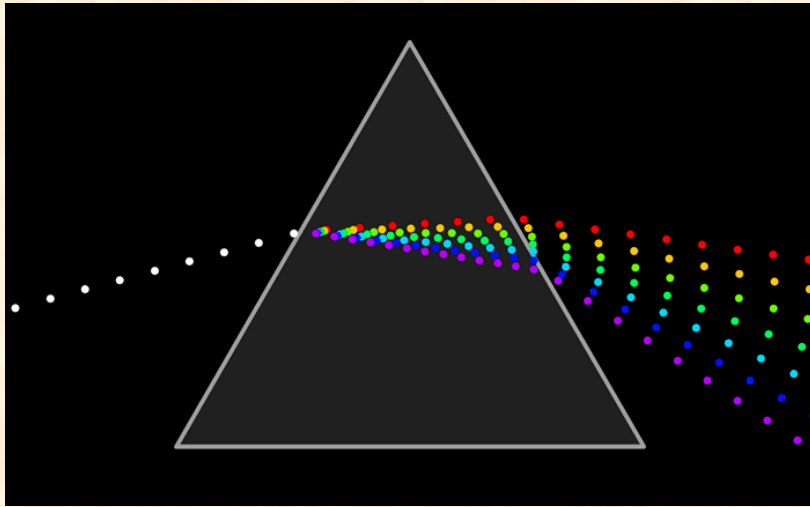

Minimum deviation condition:  $\beta = \pi - \phi - 2\alpha$

Fermat principle:  $n \cdot t = 2L \cos \alpha$

$$\Rightarrow \frac{dn}{d\beta} = -\frac{1}{2} \frac{dn}{d\alpha} = \frac{L \sin \alpha}{t} = \frac{D_1}{t}$$

$$\Rightarrow \frac{1}{D_{prism}} = \frac{d\lambda}{d\beta} = \frac{d\lambda}{dn} \cdot \frac{dn}{d\beta} = \frac{D_1}{t} \cdot \frac{d\lambda}{dn} \quad (\text{inverse dispersion})$$

# Prism characteristics

- > High transmittance
- > When used at minimum deviation, (compression or enlargement)
- > Produces 'low' dispersion

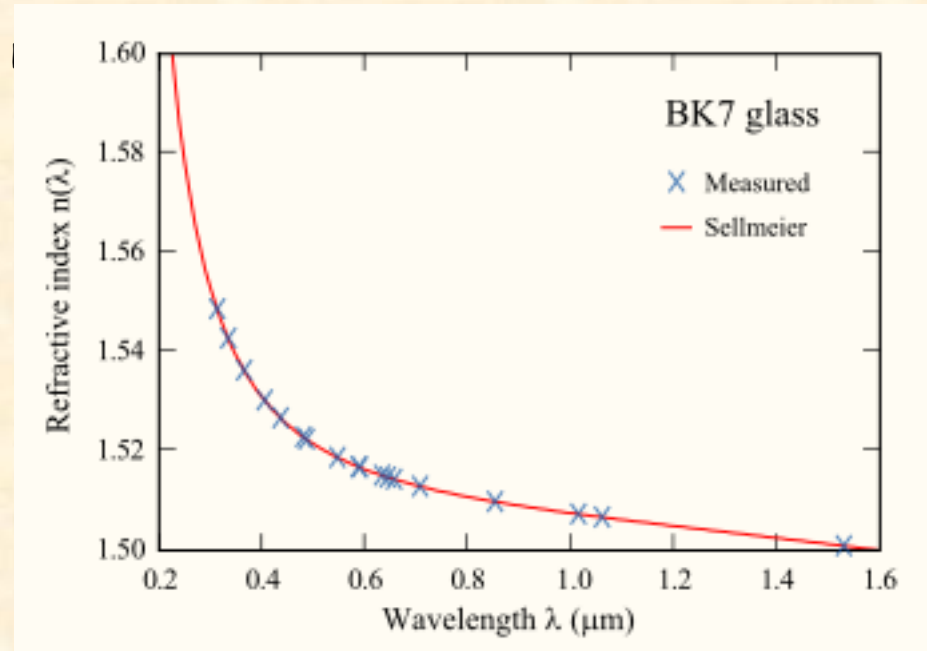

Prism example: BK7 (normal glass),  $t = 50$  mm,  $D = 100$  mm

$$D_{prism} = \frac{d\beta}{d\lambda} = \frac{t}{D_1} \cdot \frac{dn}{d\lambda} \cong 0.03 \text{ rad}/\mu\text{m} @ 550 \text{ nm}$$

# Prism characteristics

- > Depends mainly on glass material (internal transmittance)
- > Anti-reflection coatings are needed to avoid reflection losses, especially for large apex angles (and large  $\alpha$ ). The coating must be optimized for the glass and the used angles.
- > Efficiency can be as high as 99%
- > The dispersion increases towards the blue wavelengths. For **Crown** glasses (contain Potassium) the ratio of the dispersion between blue and red is lower than for **Flint** glasses (contain lead, titanium dioxide or zirconium dioxide) .

# Grating spectrograph

Focal ratios  
defined as  
 $F_i = f_i / D_i$

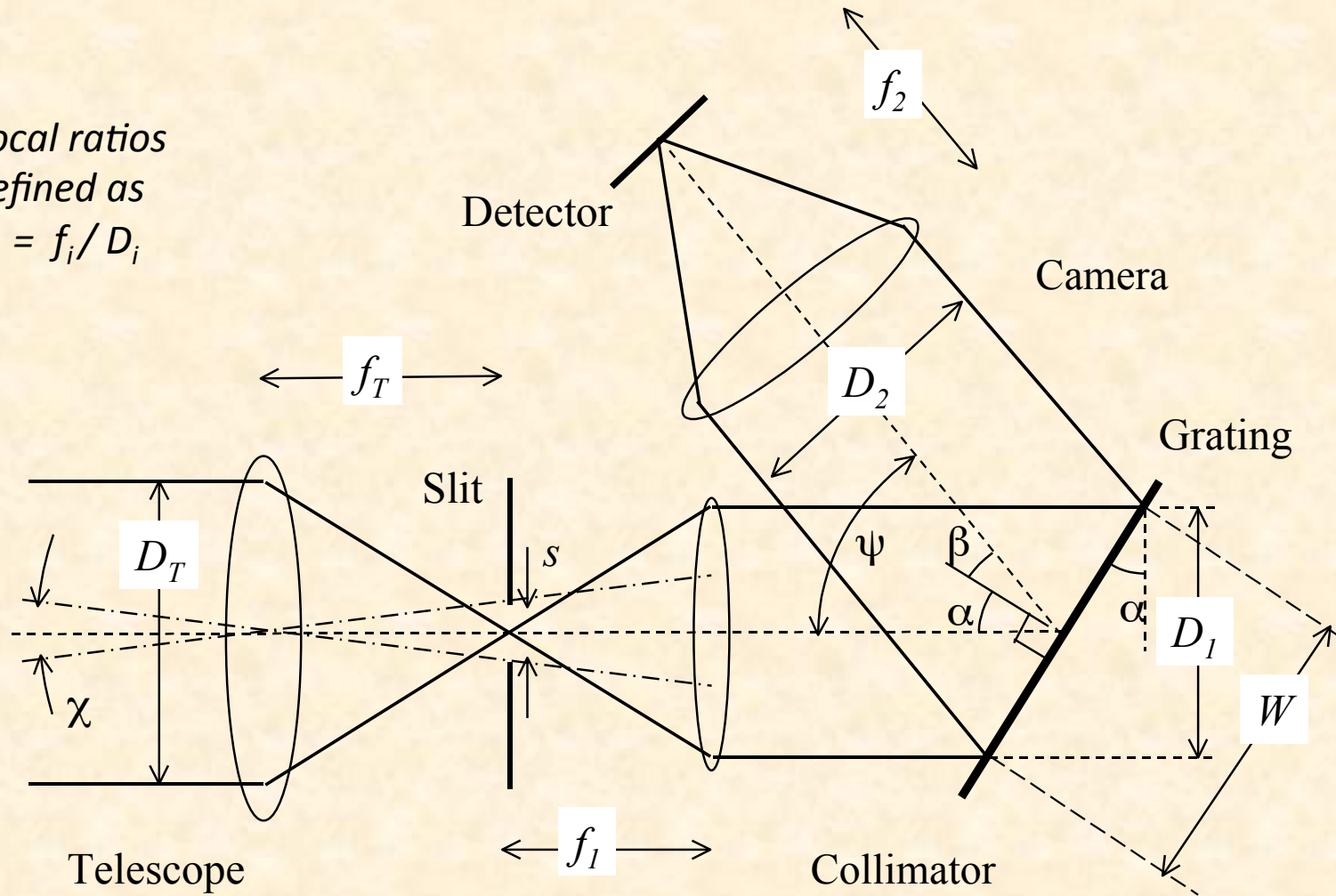

# The diffraction grating

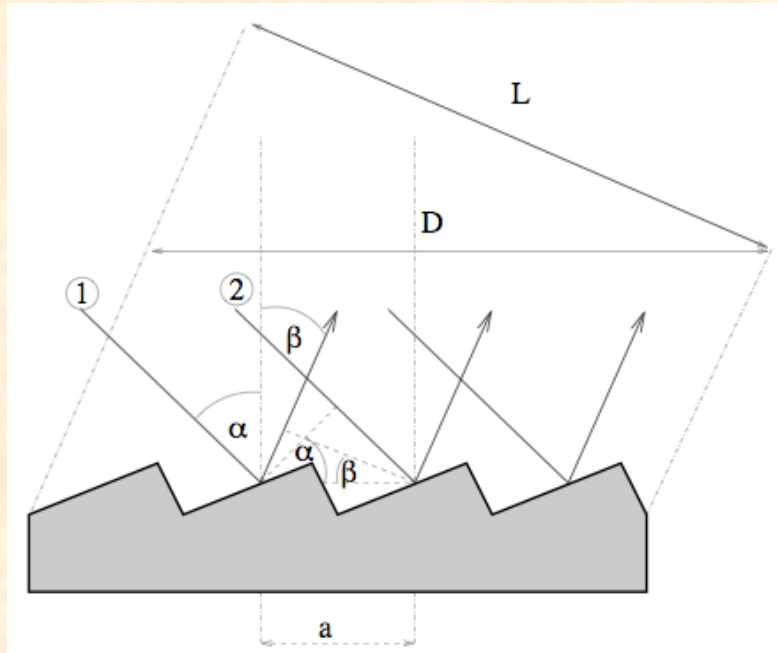

Generic grating equation from the condition of positive interference between various 'grooves':

$$m\rho\lambda = n_1 \sin \alpha + n_2 \sin \beta \quad \text{where} \quad \rho = \frac{1}{a}$$

$$m\rho\lambda = n(\sin \alpha + \sin \beta) \quad \text{reflection grating}$$

Angular dispersion :  $\frac{d\beta}{d\lambda} = \frac{m\rho}{\cos \beta}$

Linear dispersion :  $\frac{dx}{d\lambda} = \frac{dx}{d\beta} \frac{d\beta}{d\lambda} = f_2 \frac{m\rho}{\cos \beta}$

# Grating characteristics

- > Several orders result for a given wavelength
- >  $m = 0$  for a grating which acts like a mirror -> no dispersion!
- > Orders overlap **spatially** -> must be filtered or use at  $m=1$

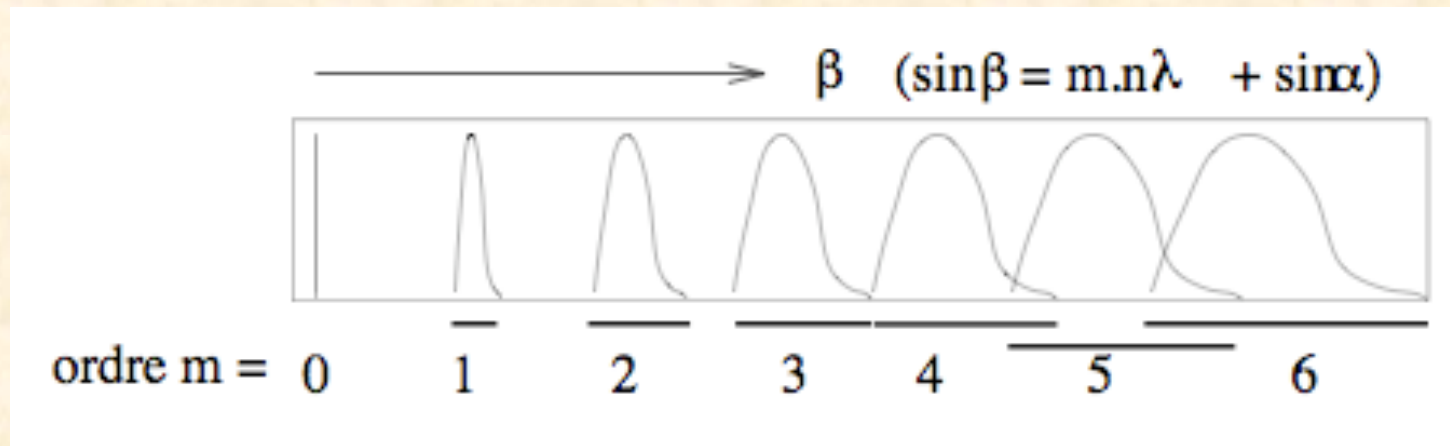

Typical grating example:  $m = 1$ ,  $\rho = 1000$  gr/mm,  $\sin \alpha + \sin \beta = 1$ ,  $\cos \beta = 1/2$

$$\Rightarrow \frac{d\beta}{d\lambda} = \frac{m\rho}{\cos \beta} = 2 \text{ rad}/\mu\text{m}$$

Dispersion typically much higher than for prisms!



# Grism efficiency

ISAAC grating efficiency (from ESO ETC)  
medium resolution grating orders 2-6

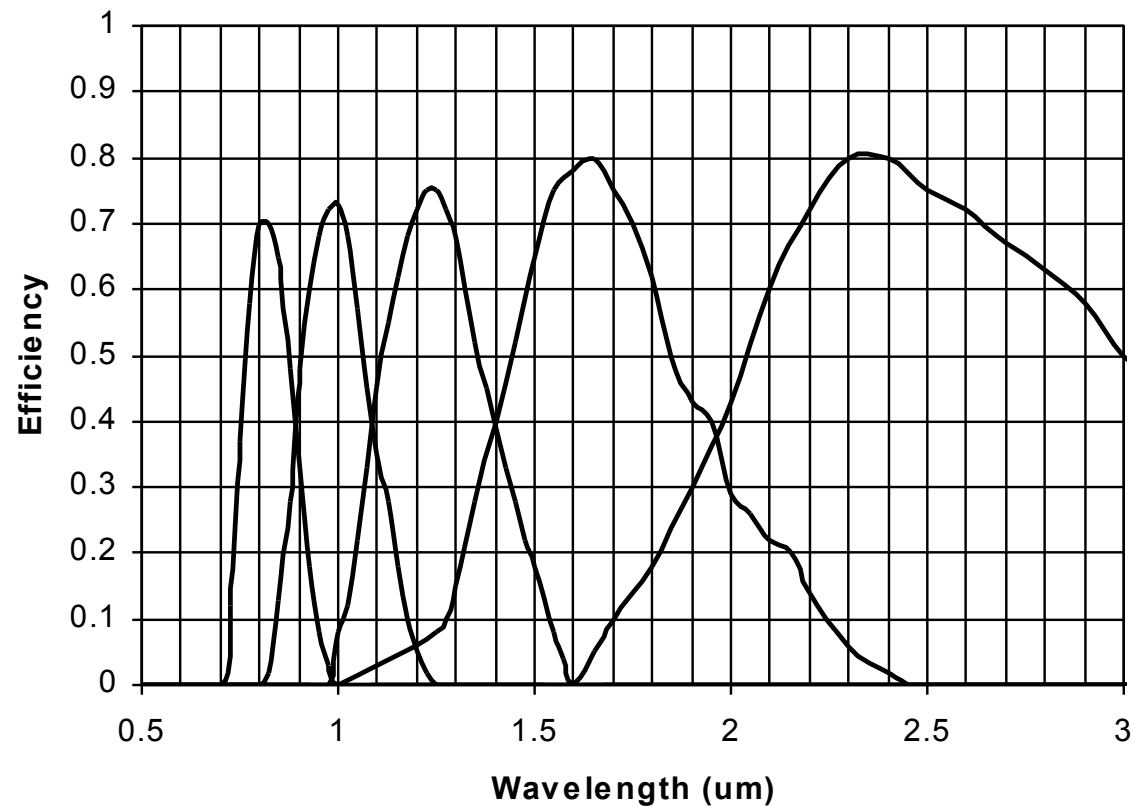

Maximum efficiency  
obtained when  
specular groove  
reflection matches  
(Blaze condition):

$$\alpha + \beta = 2\Theta$$

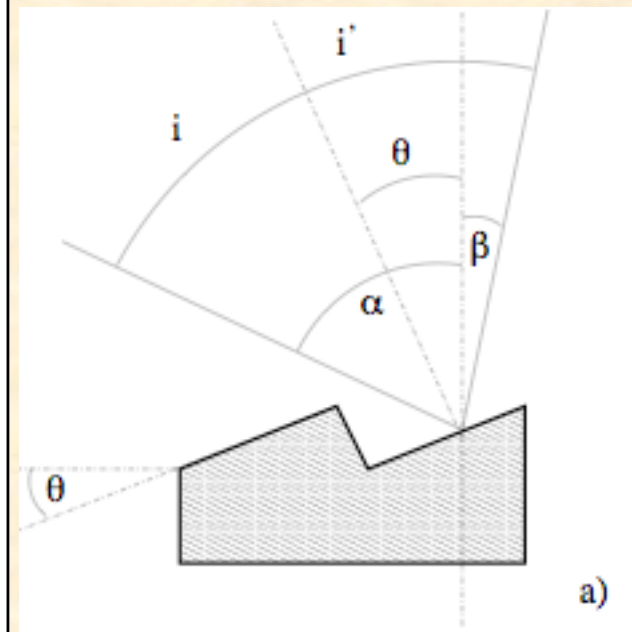

# Order overlaps

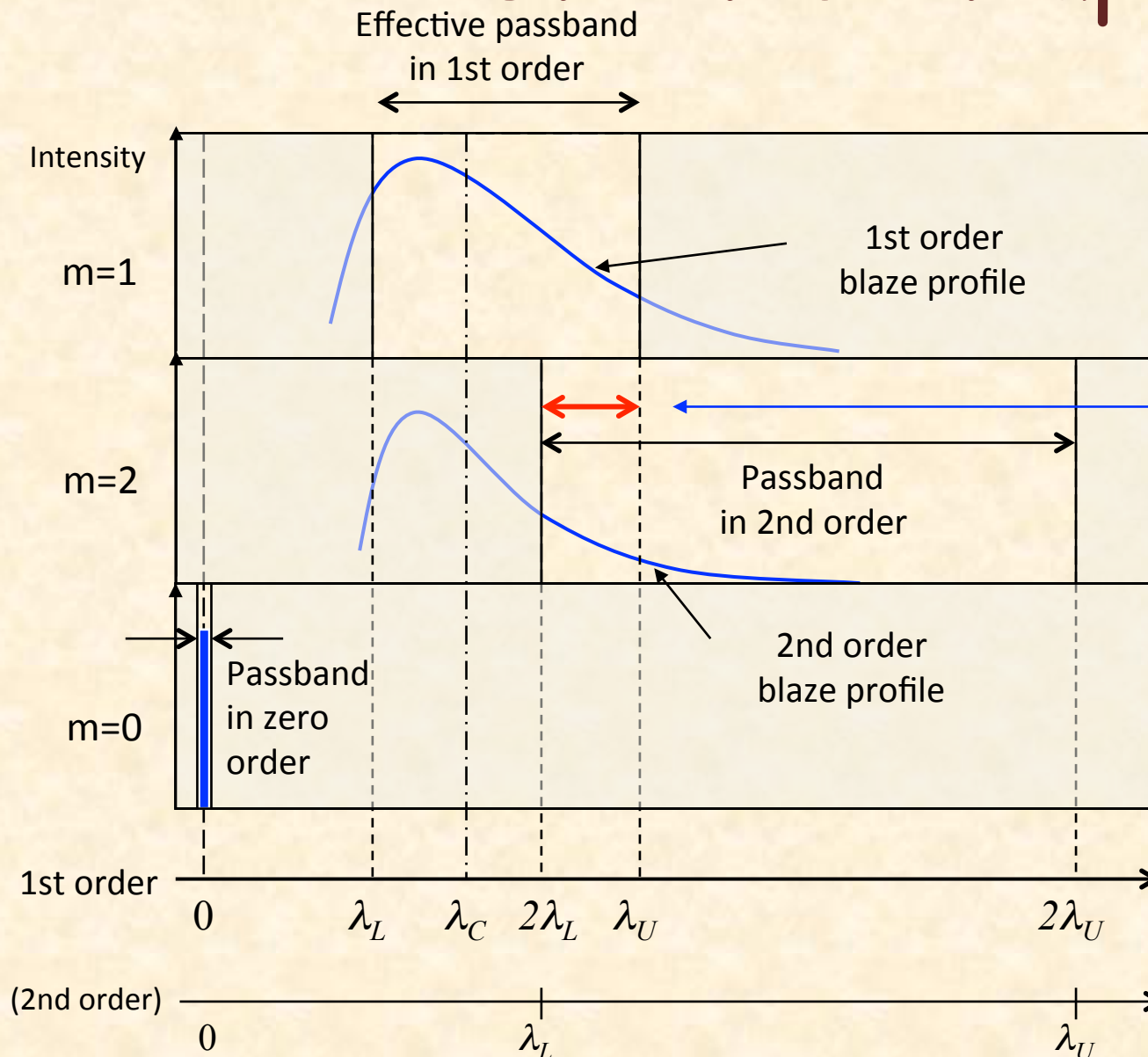

Don't forget higher orders!

First and second orders overlap!

Zero order matters for MOS

Wavelength in first order marking **position on detector** in dispersion direction (if dispersion  $\sim$ linear)

# Resolving power and resolution

Focal ratios  
defined as  
 $F_i = f_i / D_i$

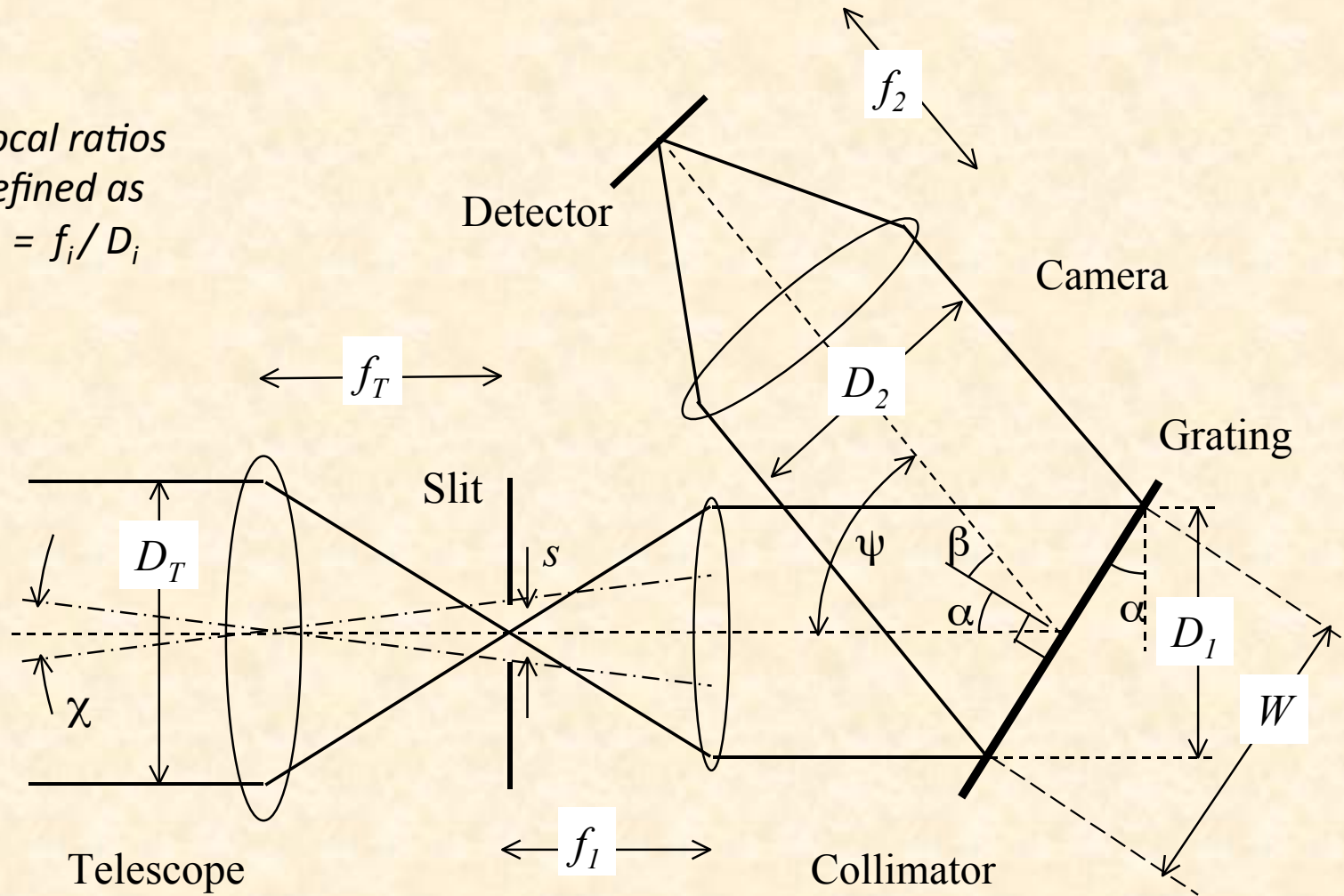

# Resolving power and resolution

The objective translates angles into positions on the detector.  
Each position (pixel) of the detector 'sees' a given angle of the parallel (collimated) beam

The collimated beam is never perfectly parallel, because either of the limited diameter of the beam, which produces diffraction  $\delta\phi = 1.22 \lambda/D_1$ , or because of the finite slit, which produces an angular divergence  $\delta\Theta = s/f_1$ .

The angular divergence is translated into a distance  $\delta\lambda = f_2 \delta\Theta$  or  $\delta\lambda = f_2 \delta\phi$  on the CCD. This means that over this distance the wavelengths are mixed (cannot be separated angularly).

# Resolving power and resolution

Resolving power is the maximum spectral resolution which can be reached if the slit  $s = 0$  and the angular divergence is limited by diffraction arising from the limited beam diameter. For a given Dispersion  $D$  we get the **resolving power**:

$$RP := \frac{\lambda}{\delta\lambda} = \frac{\lambda}{\delta\Phi / D} = \frac{\lambda}{\delta\Phi \cdot \frac{d\lambda}{d\beta}} = \frac{\lambda}{\delta\Phi} \cdot \frac{d\beta}{d\lambda}$$

Spectral resolution is the effective spectral resolution which is finally reached when assuming a finite slit  $s$ . For a given Dispersion  $D$  we get the **spectral resolution**:

$$R := \frac{\lambda}{\delta\lambda} = \frac{\lambda}{\delta\Theta / D} = \frac{\lambda}{\delta\Theta \cdot \frac{d\lambda}{d\beta}} = \frac{\lambda}{\delta\Theta} \cdot \frac{d\beta}{d\lambda}$$

# Conservation of the 'étendue'

The étendue is defined as  $E = A \times O$ , where  $A$  is the area of the beam at a given optical surface and  $O$  is the solid angle under which the beam passes through the surface.

When following the optical path of the beam through an optical system,  $E$  is constant, in particular, it cannot be reduced

For a telescope,  $E$  is the product of the primary mirror surface and the two-dimensional field (in sterad) transmitted by the optical system. Normally, the transmitted field is defined as a slit width. When entering spectrograph, the slit  $\times$  beam aperture at the slit is equal to the étendue  $E$  of the telescope. This implies that at fixed spectral resolution, the slit width and the beam diameter cannot be chosen independently, since  $d\Theta$  depends on both.

# Other dispersers

- Grisms
- VPHG
- Echelle grating

# Grisms

- Transmission grating attached to prism
- Allows in-line optical train:
  - simpler to engineer
  - quasi-Littrow configuration - no variable anamorphism
- Inefficient for  $\rho > 600/\text{mm}$  due to groove shadowing and other effects

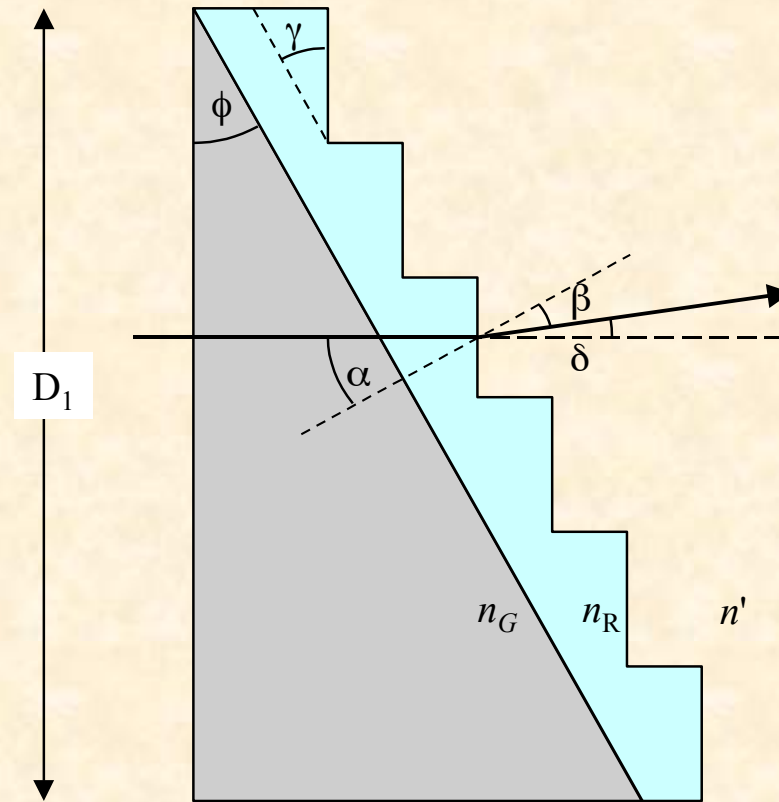



# Grism equations

- Modified grating equation:

$$m\rho\lambda = n \sin \alpha + n' \sin \beta$$

- Undeviated condition:

$$n' = 1, \beta = -\alpha = \phi$$

$$m\rho\lambda_U = (n - 1) \sin \phi$$

$\theta$  = phase difference from  
centre of one ruling to its edge

- Blaze condition:

$$\theta = 0 \Rightarrow \lambda_B = \lambda_U$$

- Resolving power  
(same procedure as for grating)

$$R = \frac{m\rho\lambda W}{\chi D_T}$$

$$W = \frac{D_1}{\cos \phi}$$

$$R = \frac{(n - 1) \tan \phi D_1}{\chi D_T}$$

# Volume Phase Holographic gratings

- So far we have considered *surface relief* gratings
- An alternative is *VPH* in which refractive index varies harmonically throughout the body of the grating:
- Don't confuse with '*holographic*' gratings (SR)
- **Advantages:**  $n_g(x, z) = n_g + \Delta n_g \cos[2\pi\rho_g(x \sin \gamma + z \cos \gamma)]$ 
  - Higher peak efficiency than SR
  - Possibility of very large size with high  $\rho$
  - Blaze condition can be altered (*tuned*)
  - Encapsulation in flat glass makes more robust
- **Disadvantages**
  - Tuning of blaze requires *bendable spectrograph!*
  - Issues of wavefront errors and cryogenic use

# VPH configurations

- *Fringes* = planes of constant  $n$
- Body of grating made from *Dichromated Gelatine* (DCG) which permanently adopts fringe pattern generated holographically
- Fringe orientation allows operation in transmission or reflection

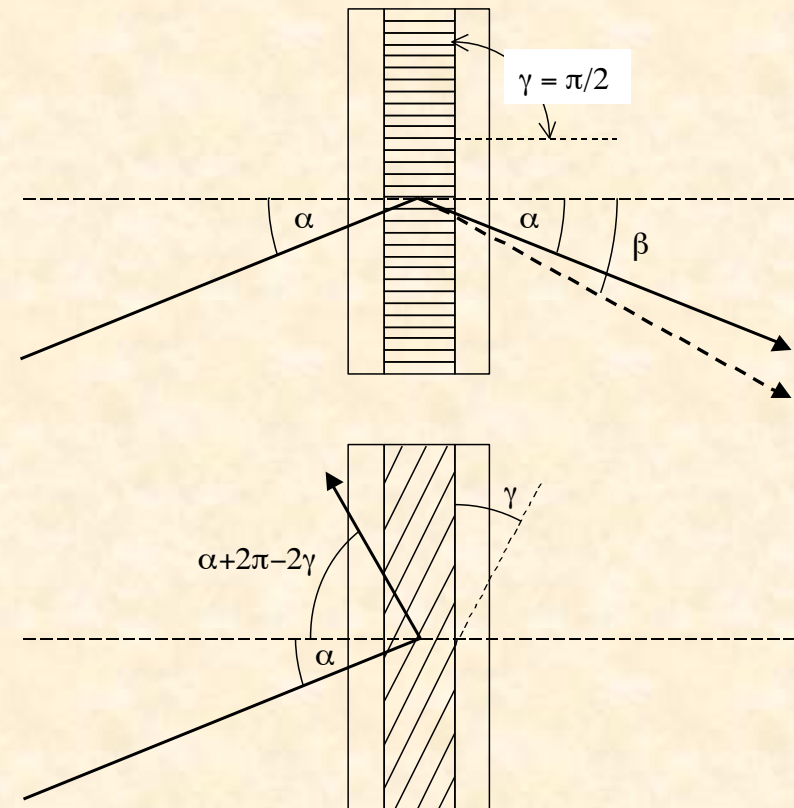

# VPH equations

- Modified grating equation:

$$m\rho\lambda = \sin \alpha + \sin \beta$$

- Blaze condition:

$$m\rho\lambda_B = 2n_g \sin \alpha_g = 2 \sin \alpha$$

= *Bragg* diffraction

$$n_g \sin \alpha_g = \sin \alpha$$

- Resolving power:

$$R = \frac{m\rho\lambda W}{\chi D_T} = \frac{m\rho\lambda}{\chi D_T} \frac{D_1}{\cos \alpha}$$

- Tune blaze condition by tilting grating ( $\alpha$ )

- Collimator-camera angle must also change by  $2\alpha \Rightarrow$  mechanical complexity

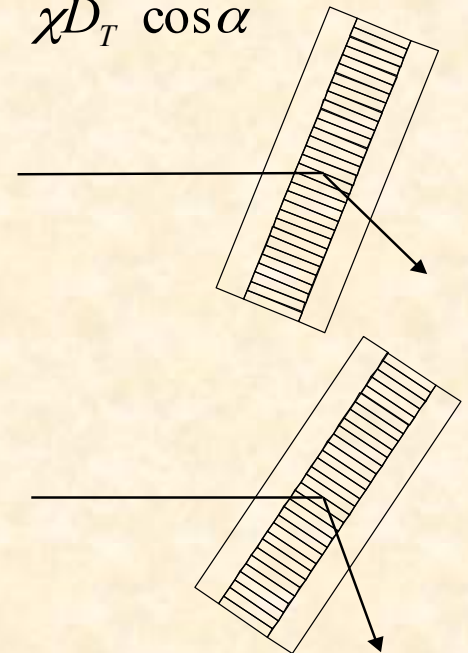

# VPH efficiency

- Kogelnik's analysis when:

$$\frac{2\pi\lambda d\rho_g^2}{n_g} > 10$$

- Bragg condition when:

$$\Delta n_g d \approx \frac{\lambda}{2}$$

- Bragg envelopes (efficiency FWHM):

– in wavelength:

$$\Delta\lambda \propto \left( \frac{1}{\rho_g \tan \alpha_g} \right) \Delta n_g = \left( \frac{1}{\rho_g \tan \alpha_g} \right) \frac{\lambda}{d}$$

– in angle:

$$\Delta\alpha \propto \frac{1}{\rho_g d}$$

- Broad blaze requires
  - thin DCG
  - large index amplitude
- *Superblaze*

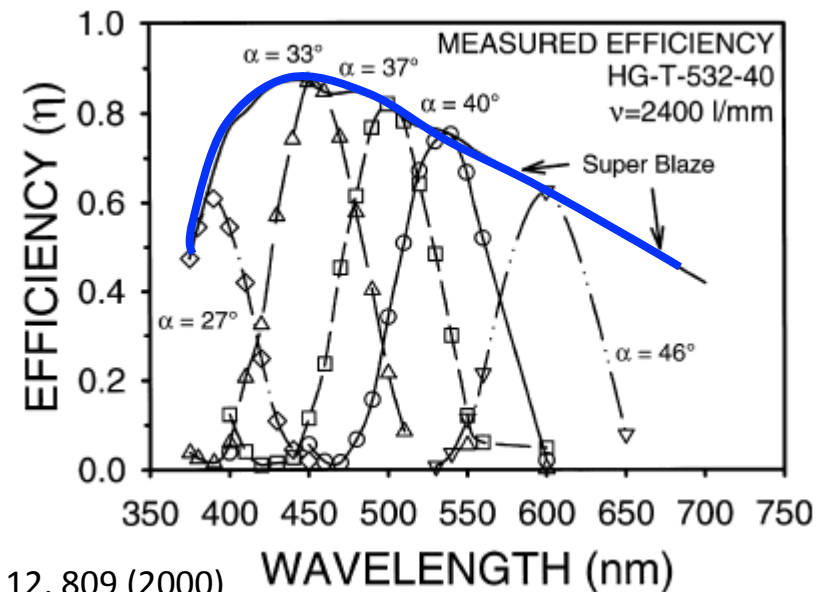

# Resolving power and resolution

The objective translates angles into positions on the detector.  
Each position (pixel) of the detector 'sees' a given angle of the parallel (collimated) beam

The collimated beam is never perfectly parallel, because either of the limited diameter of the beam, which produces diffraction  $\delta\phi = 1.22 \lambda/D_1$ , or because of the finite slit, which produces an angular divergence  $\delta\Theta = s/f_1$ .

The angular divergence is translated into a distance  $\delta\lambda = f_2 \delta\Theta$  or  $\delta\lambda = f_2 \delta\phi$  on the CCD. This means that over this distance the wavelengths are mixed (cannot be separated angularly).

# Resolving power and resolution

Resolving power is the maximum spectral resolution which can be reached if the slit  $s = 0$  and the angular divergence is limited by diffraction arising from the limited beam diameter. For a given Dispersion  $D$  we get the **resolving power**:

$$RP := \frac{\lambda}{\delta\lambda} = \frac{\lambda}{\delta\Phi / D} = \frac{\lambda}{\delta\Phi \cdot \frac{d\lambda}{d\beta}} = \frac{\lambda}{\delta\Phi} \cdot \frac{d\beta}{d\lambda}$$

Spectral resolution is the effective spectral resolution which is finally reached when assuming a finite slit  $s$ . For a given Dispersion  $D$  we get the **spectral resolution**:

$$R := \frac{\lambda}{\delta\lambda} = \frac{\lambda}{\delta\Theta / D} = \frac{\lambda}{\delta\Theta \cdot \frac{d\lambda}{d\beta}} = \frac{\lambda}{\delta\Theta} \cdot \frac{d\beta}{d\lambda}$$

# Example of spectrographs

## Basic Parameters

- Telescope diameter:  $D_T$
- Source/seeing/slit:  $s_{sky}$
- Collimated beam of the spectrograph:  $D_1$

## Other parameters:

- Telescope focal length:  $f_T$
- Telescope F-number (focal ratio):  $F_T = F = f_T/D_T$
- Physical slit/fiber width:  $s = f_T \times s_{sky}$
- Collimator focal length:  $f_1$
- Objective focal length:  $f_2$



# Grating spectrograph

Focal ratios  
defined as  
 $F_i = f_i / D_i$

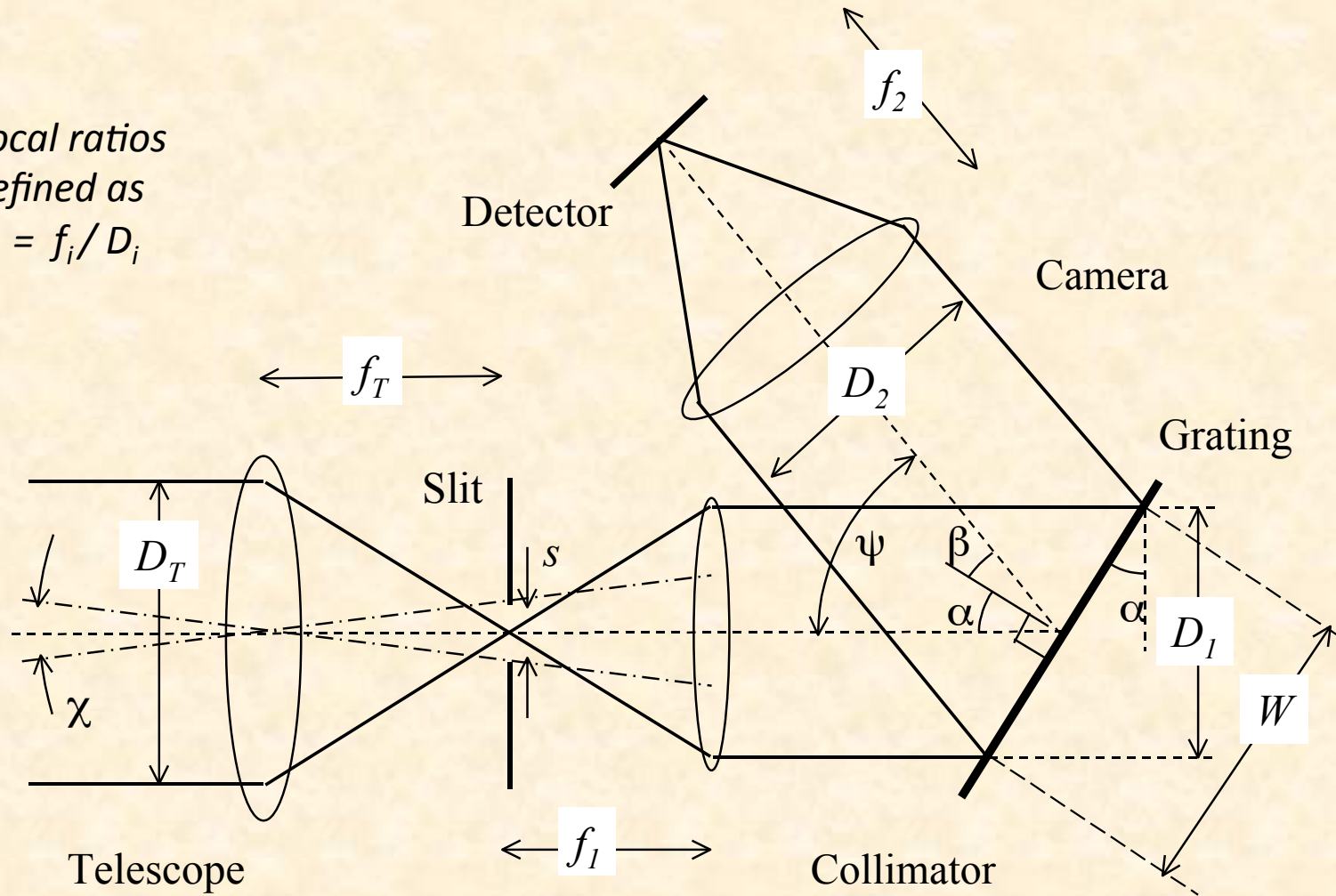

# Example of simple spectrographs

Spectral resolution:

$$R := \frac{\lambda}{\delta\lambda} = \frac{\lambda}{\delta\Theta} \cdot Disp = \frac{\lambda}{\frac{s}{f_1}} \cdot Disp = \frac{\lambda}{\frac{f_T \cdot s_{Sky}}{f_T \cdot D_1}} \cdot Disp = \lambda \cdot \frac{D_1}{D_T} \cdot \frac{Disp}{s_{Sky}}$$

where

$$Disp = \frac{d\beta}{d\lambda}$$

# Example of 'simple' spectrographs

Coralie@Euler:

- Telescope diameter:  $D_T = 1.2$  m
- Source/seeing/slit:  $s_{sky} = 1$  arcsec
- Collimated beam of the spectrograph:  $D_1 = 75$  mm

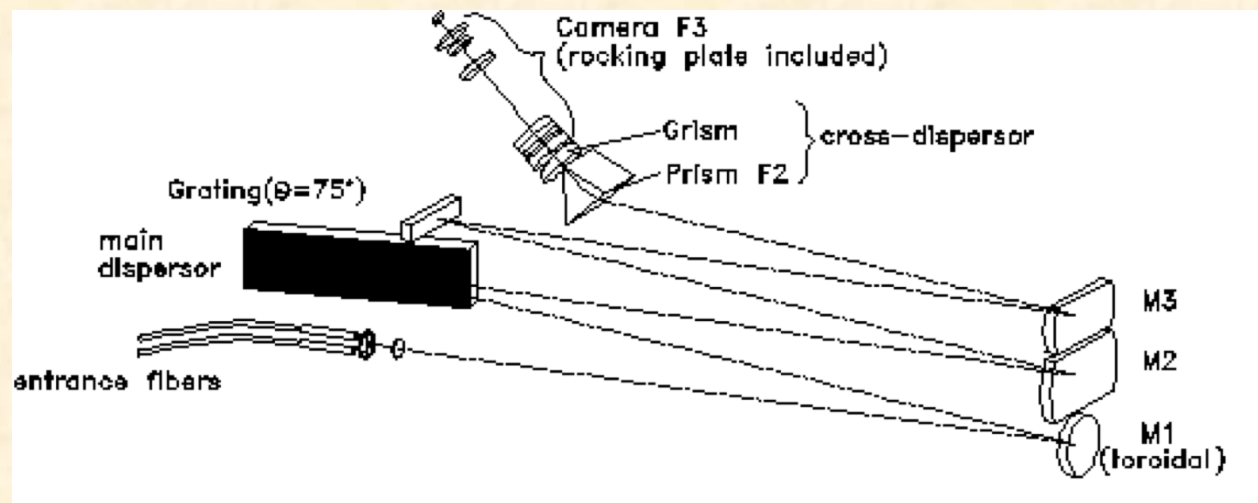

# Example of 'simple' spectrographs

With prism: BK7 (normal glass),  $t = 50$  mm

$$D_{prism} = \frac{d\beta}{d\lambda} = \frac{t}{D_1} \cdot \frac{dn}{d\lambda} \cong 0.04 \text{ rad}/\mu\text{m} @ 550 \text{ nm}$$

$$R_{prism} = \frac{\lambda}{\delta\lambda} = \lambda \cdot \frac{D_1}{D_T} \cdot \frac{D_{prism}}{s_{Sky}} = 0.55 \cdot \frac{0.075}{1.2} \cdot \frac{0.04}{5 \cdot 10^{-6}} \approx 275$$

With grism:  $m = 1$ ,  $\rho = 150$  gr/mm,  $\cos\beta=1$

$$D_{grism} = \frac{d\beta}{d\lambda} = \frac{m\rho}{\cos\beta} = 0.15 \text{ rad}/\mu\text{m}$$

$$R_{grism} = \frac{\lambda}{\delta\lambda} = \lambda \cdot \frac{D_1}{D_T} \cdot \frac{D_{grism}}{s_{Sky}} = 0.55 \cdot \frac{0.075}{1.2} \cdot \frac{0.15}{5 \cdot 10^{-6}} \approx 1000$$



# FORS@VLT

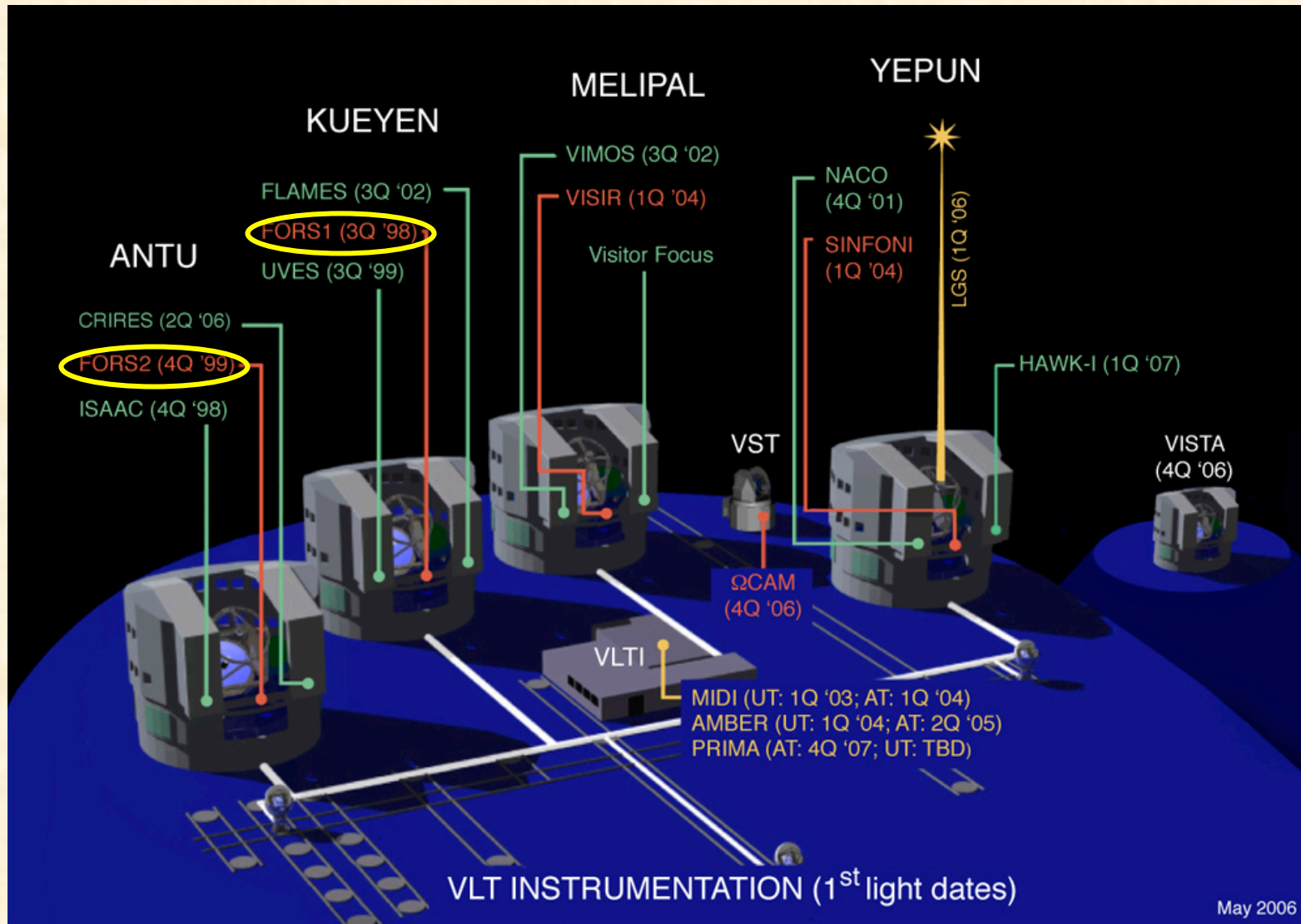

# FORS@VLT

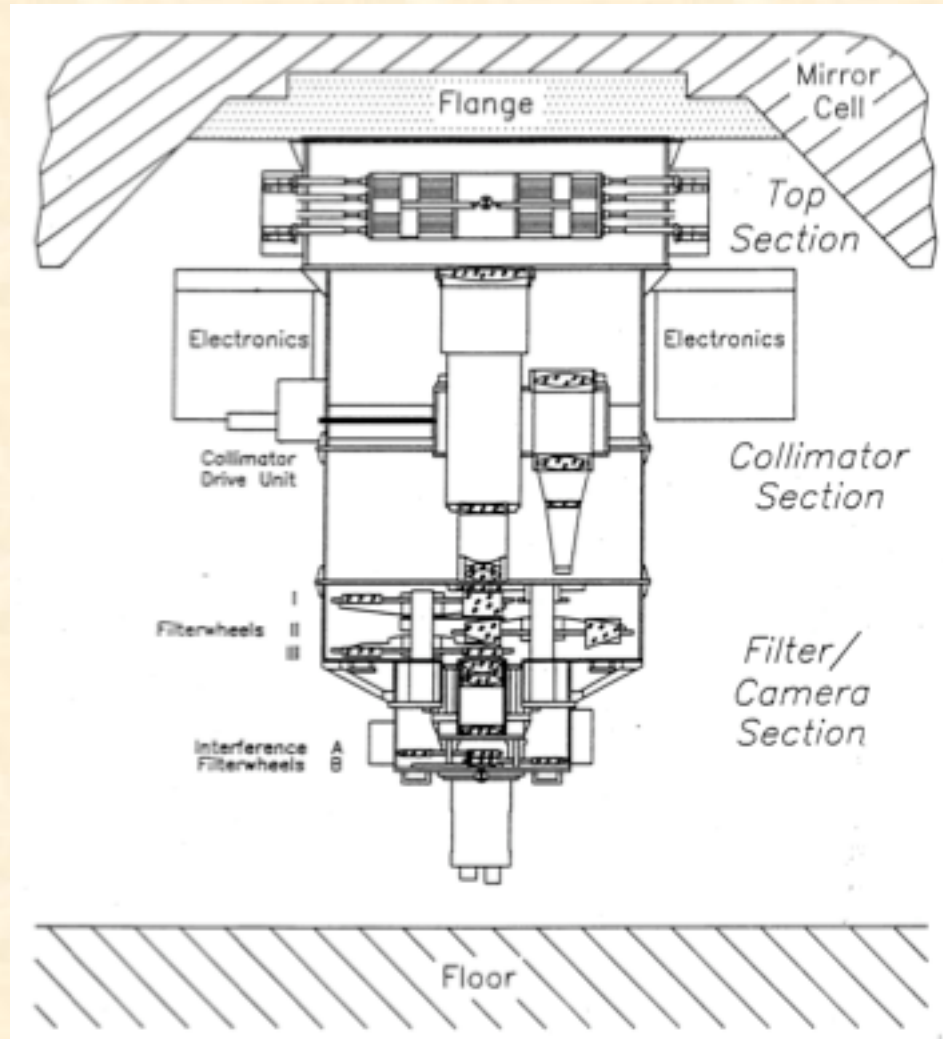

# FORS@VLT

Standard Resolution

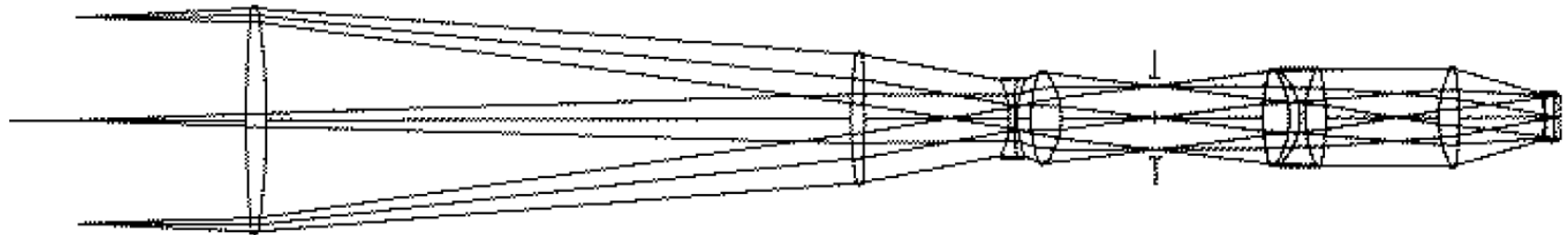

Collimator

Camera

High Resolution

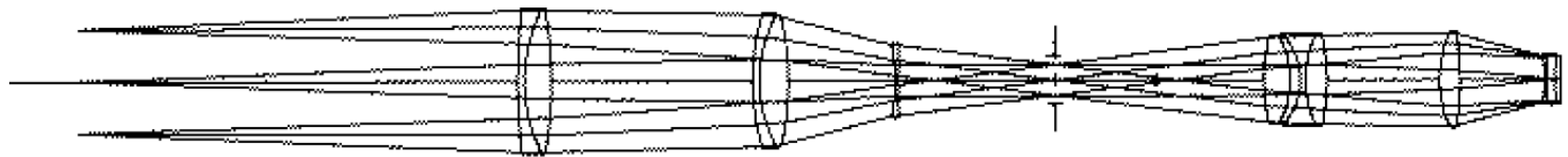

250. mm



# FORS: Filter mode

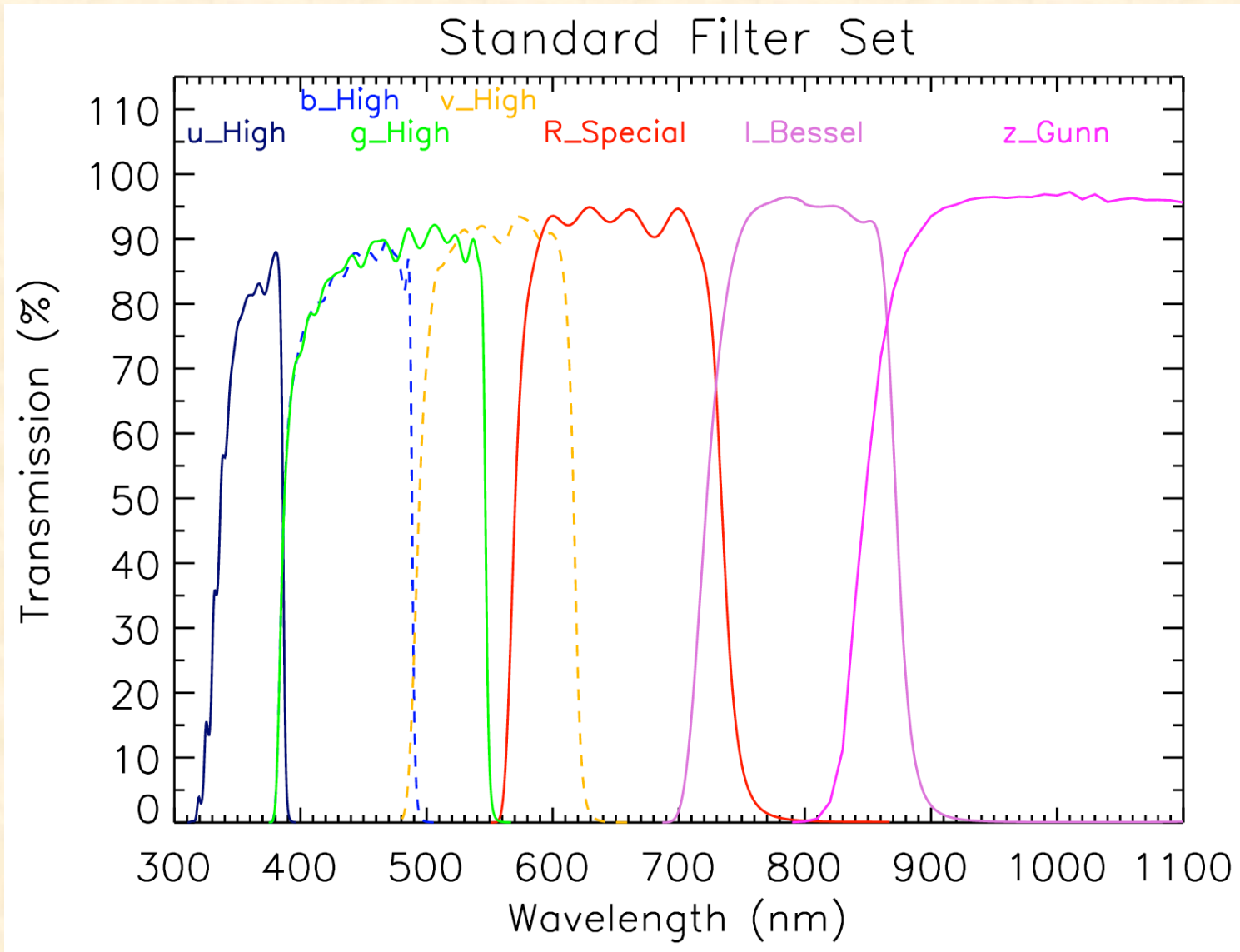

# FORS: Grism mode

- Grisms from 150 gr/mm to 1400 gr/mm
- Spectroscopic modes
  - 'slitless' MOS mode (R is given by seeing)
  - Mask with up to 9 'long slits' of 0.3" x 6.8'
  - Up to 19 movable 'slitlets' of 0.3" x 22.5"
  - MOS-MXU: Laser-cut masks (any format)
- Spectral resolution depends on grism dispersion and slit width in **dispersion** direction.

File View Graphics Go Data-Servers FORS2 Help

ROT = 0.0  
RA = 00:56:12.000  
DEC = -72:08:51.999

CCD master

Movable slitlets (localized sources in 'crowded fields')

Long slit (extended sources, 1-D image + spectrum)

CCD slave

Object: fsmosaic\_1007  
X: 1886.0  
Y: 2316.0  
Value: 301  
α: 00:24:07.536  
δ: -72:08:51.43  
Equinox: 2000  
Min: 0  
Max: 48490  
Bitpix: 16  
Low: 100  
High: 1000  
Auto Set Cut Levels  
Scale: 1/3x

image: = select object, = scroll image, = measure WCS, Control = select region

# FORS: MOS mode

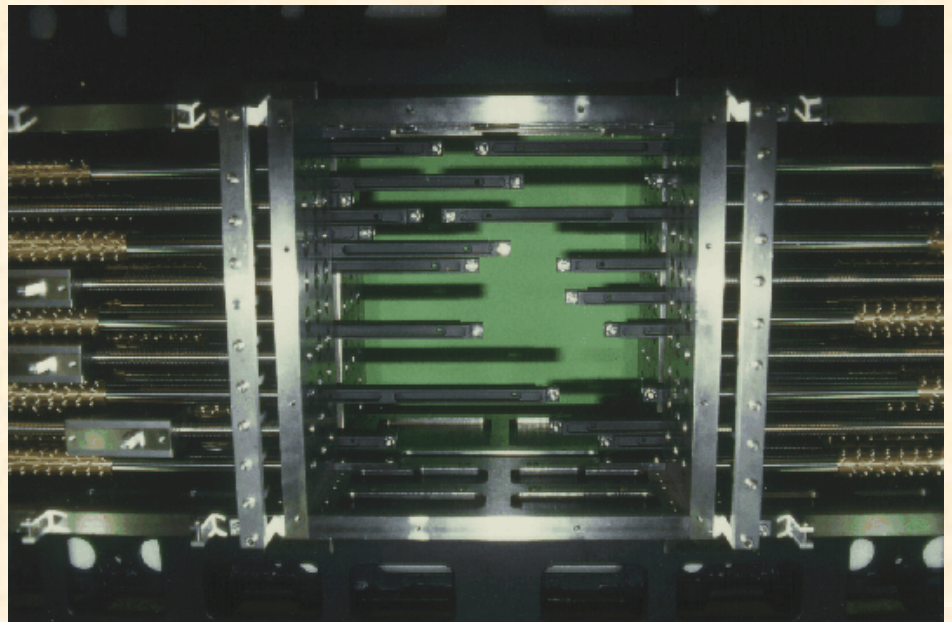
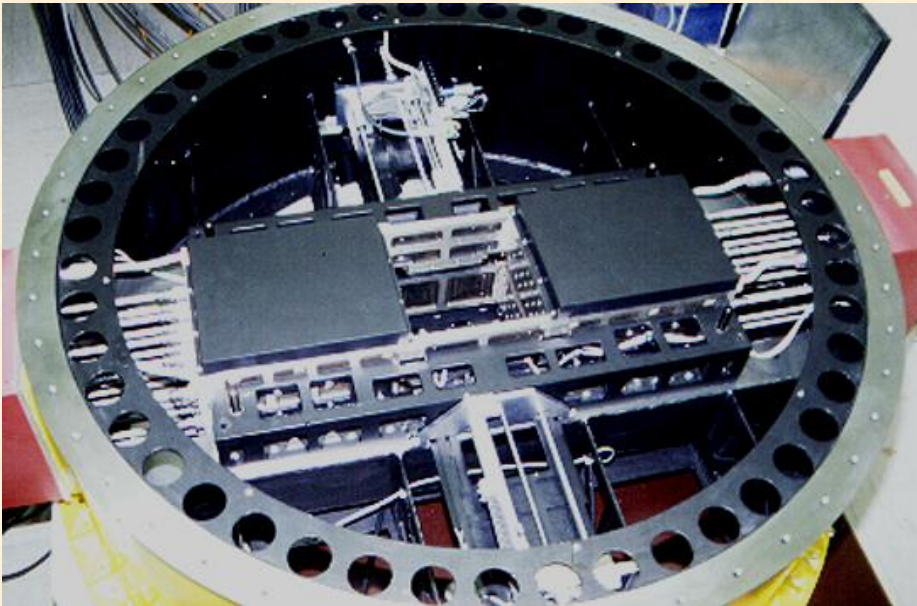

# FORS@VLT

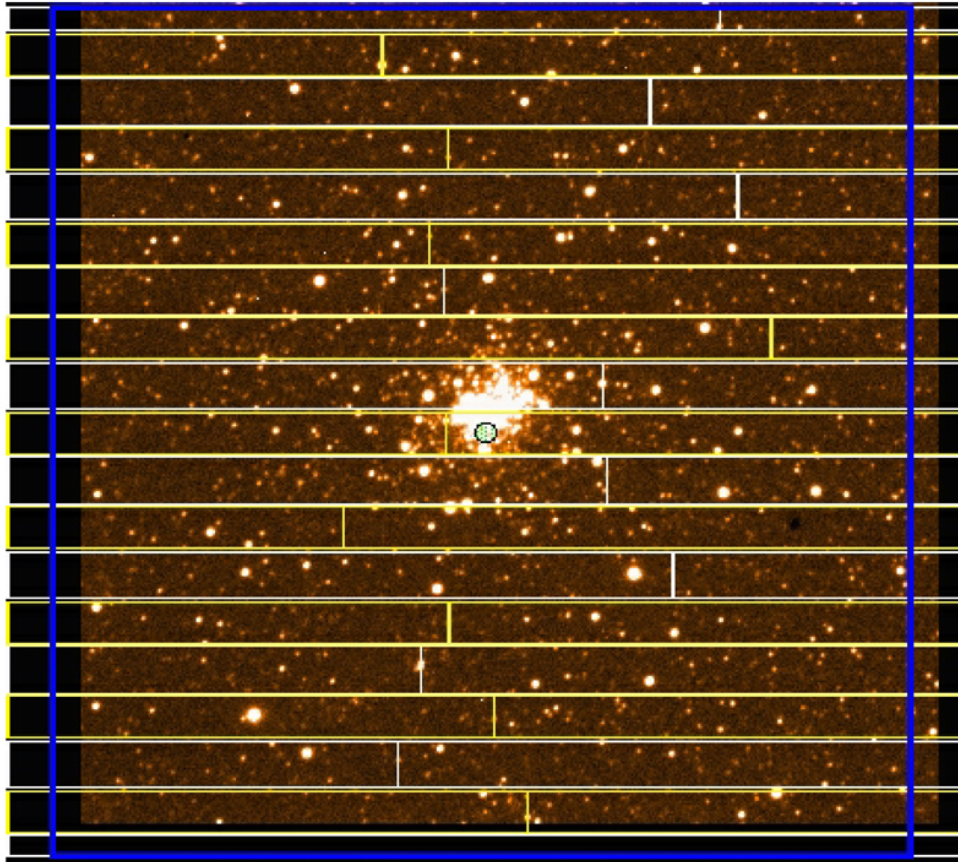

Open Cluster NGC 330 in SMC - VLT UT1 + FORS1 (MOS-mode)

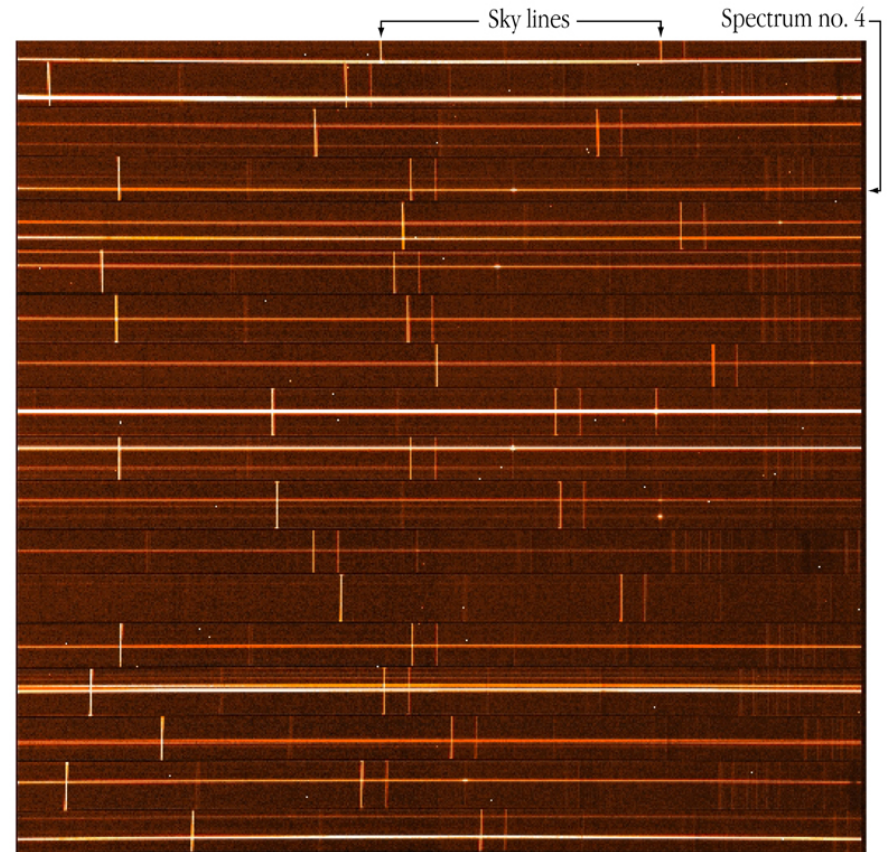

Spectra of Stars in Open Cluster NGC 330 in SMC - VLT UT1 + FORS1 (MOS-mode)



# FORS@VLT

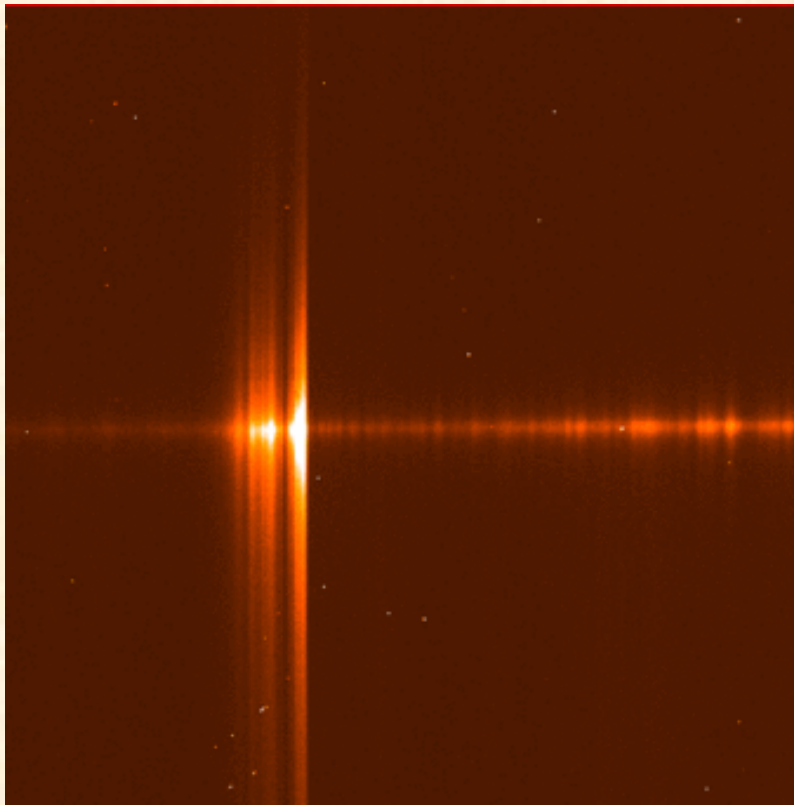

This image shows the first spectrum obtained of the comet 1995 Q1. The spectral coverage extends from about 3650 Angstrom (left) to 4100 Angstrom (right) in the violet region. The spectrograph slit was oriented along the main tail at position angle  $\sim 145$  degrees. The total slit length was 5.6 arcminutes. The spectrum is typical for a comet at Comet Bradfield's current distance from the Sun (0.5 A.U., or about 75 million kilometres).

# FORS: Spectral resolution

- Telescope diameter:  $D_T = 8.2$  m
- Source/seeing/slit:  $s_{sky} = 0.3$  arcsec
- Collimated beam :  $D_1 = 125$  mm

FORS2 cross disperser gratings for the HITS mode					
Grism	$\lambda_{central}$ [Å]	$\lambda_{range}$ [Å]	dispersion [Å/mm]/[Å/pixel]	$\lambda/\Delta\lambda$ at $\lambda_{central}$	filter
XGRIS_600B+92	4452	3300 - 6012	50/0.75	780	
XGRIS_300I+91	8575	6000 - 11000	108/1.62	660	OG590+32
XGRIS_300I+91	8575	5032 - (6600)	108/1.62	660	

With grism:  $m = 1$ ,  $\rho = 1400$  gr/mm,  $\cos\beta=1$

$$D_{grism} = \frac{d\beta}{d\lambda} = \frac{m\rho}{\cos\beta} = 1.4 \text{ rad}/\mu\text{m}$$

$$R_{grism} = \frac{\lambda}{\delta\lambda} = \lambda \cdot \frac{D_1}{D_T} \cdot \frac{D_{grism}}{s_{Sky}} = 0.55 \cdot \frac{0.125}{8.2} \cdot \frac{1.4}{5 \cdot 10^{-6}} \approx 2350$$

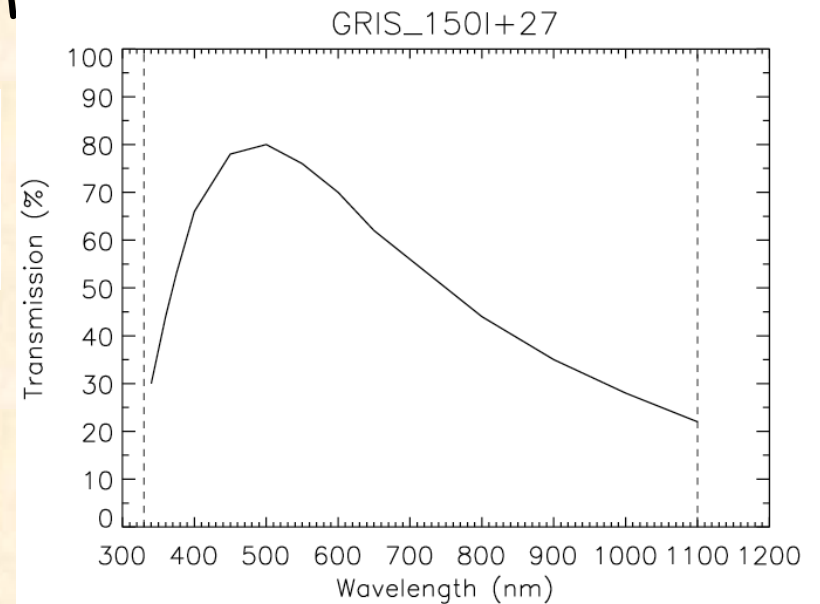

# Example of 'simple' spectrographs

- With single prisms resolution remains small
- Possibility to increase dispersion by adding up several prisms
- With gratings or grisms, the spectral resolution is up to several 1000 but still modest.
- Other 'tricks' required





# Echelle grating

- Increase dispersion of the ordinary grating by increasing the difference between entrance and exit angle
- The use in Littrow condition will make the mounting symmetric and maximize  $\alpha + \beta$ , since  $\alpha$  is set equal to  $\beta$ :  $\alpha = \beta$
- Use in blaze condition for maximum efficiency:  
Groove angle  $\gamma = \beta$

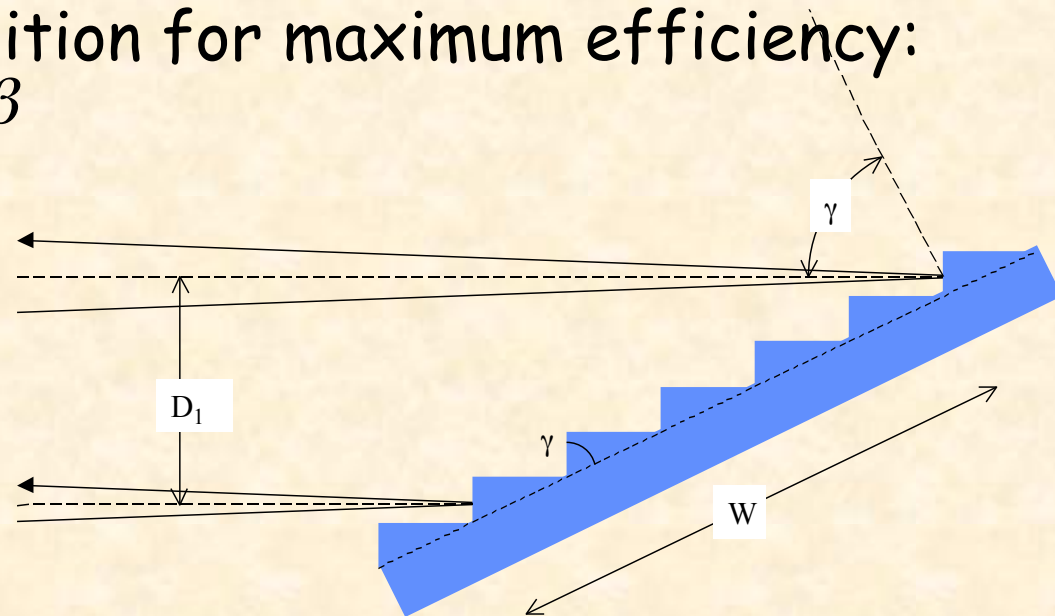

# Echelle grating

From the grating equation we derive the dispersion law of an echelle grating:

$$n \sin \beta(\lambda) = m\rho\lambda - n \sin(\alpha) \quad | \quad d/d\lambda$$

$$\Rightarrow n \cos \beta \cdot \frac{d\beta}{d\lambda} = m\rho$$

$$\Rightarrow \frac{d\beta}{d\lambda} = \frac{m\rho}{n \cos \beta} = \frac{n(\sin \alpha + \sin \beta)}{n \cos \beta \cdot \lambda} = \frac{2 \sin \beta}{\cos \beta \cdot \lambda} = \frac{2 \tan \beta}{\lambda}$$

Example: R = 4 grating:

$$\Rightarrow \frac{d\beta}{d\lambda} = \frac{8}{\lambda} \cong 15 \text{ rad } \mu\text{m}^{-1} \quad !!!$$

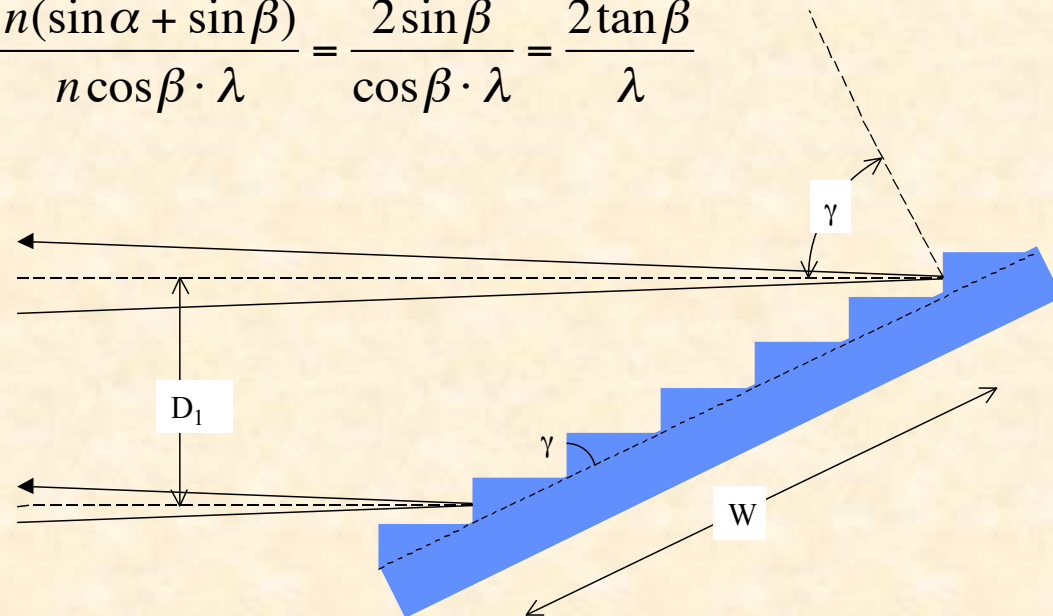

# Characteristics of Echelle grating

- High dispersion -> high resolution
- Spectrum becomes VERY long and efficiency drops because of blaze function
- Alternative: use at high order, e.g.  $m = 100$  ( $\rho = 30$  gr/mm)
- -> Orders overlap spacially and must be separated (filtering, pre-dispersion or cross-dispersion)

Free spectral range:  $F_{\lambda} = \frac{\lambda}{m}$

Numbers of orders for full 'octave':  $N = \frac{m}{2}$

# Multiple orders

- Many orders to cover desired  $\lambda$ : *Free spectral range*

$$F_{\lambda} = \lambda/m$$

- Orders lie on top of each other:

$$\lambda(m) = \lambda(n) \times (n/m)$$

- Solution:
  - use narrow passband filter to isolate one order at a time
  - cross-disperse to fill detector with many orders at once

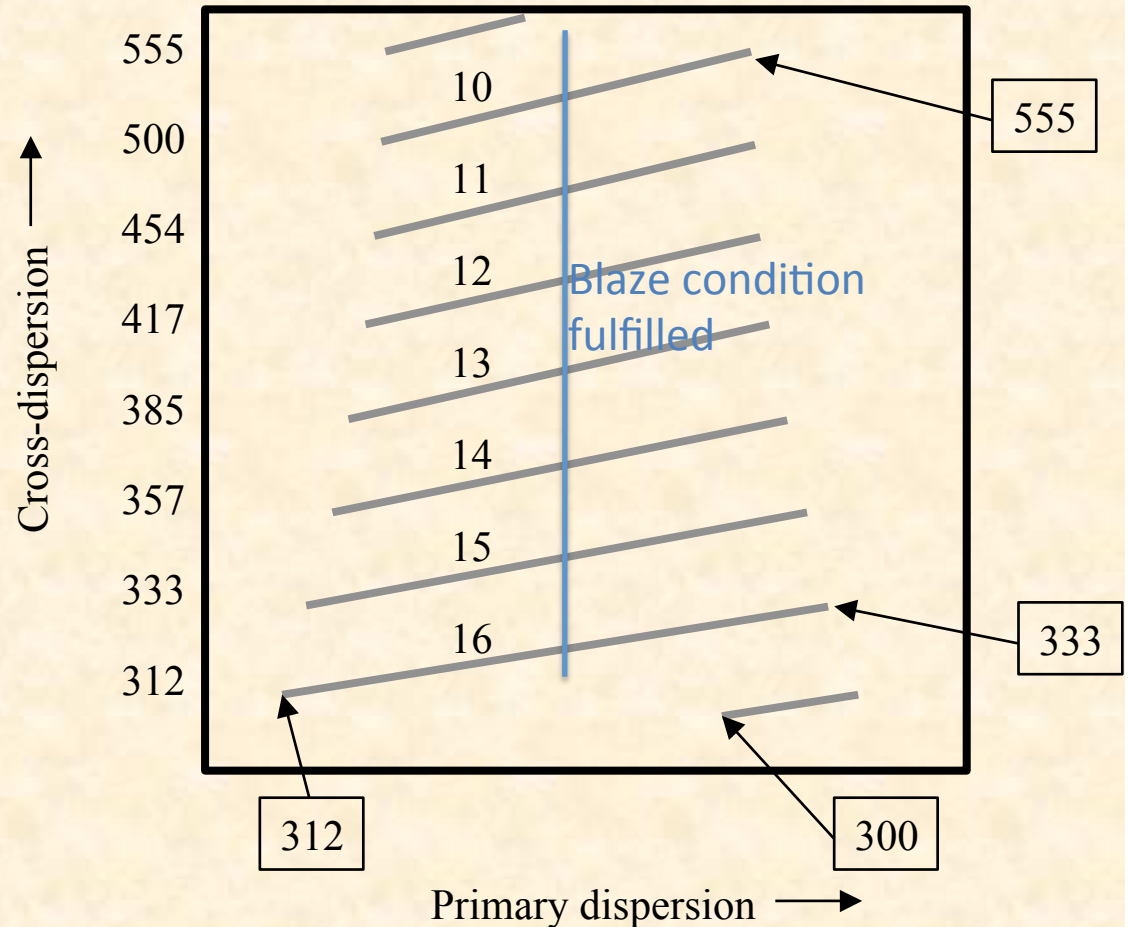

Cross dispersion may use prisms or low dispersion grating

Cross dispersion (prism, grism, grating) ->

Monochromatic image of the slit



Main dispersion (echelle grating) ->

# UVES@VLT

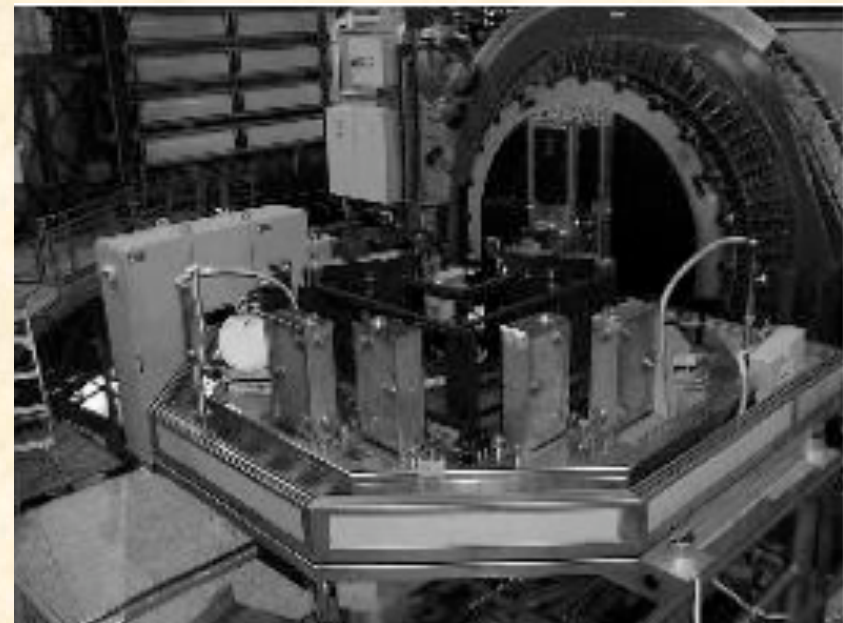
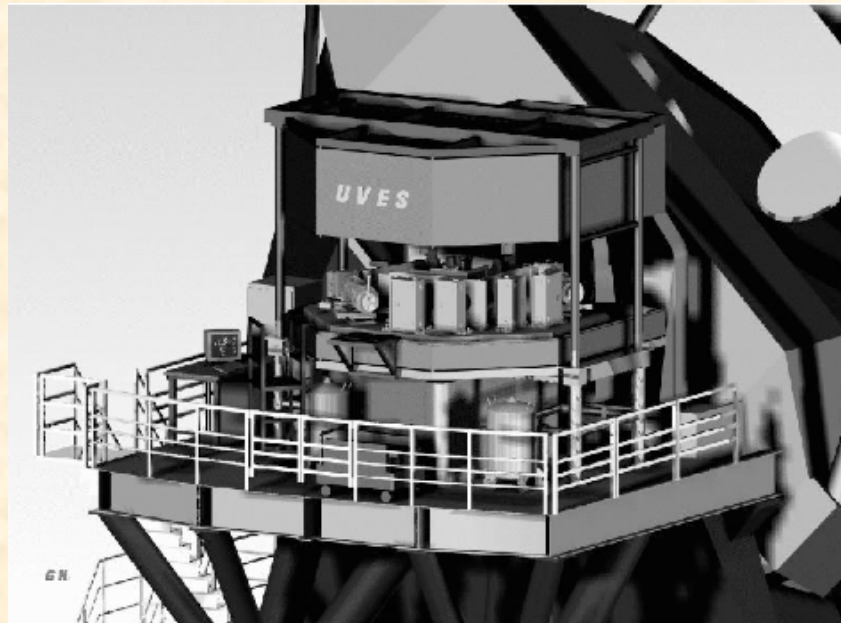

# UVES@VLT

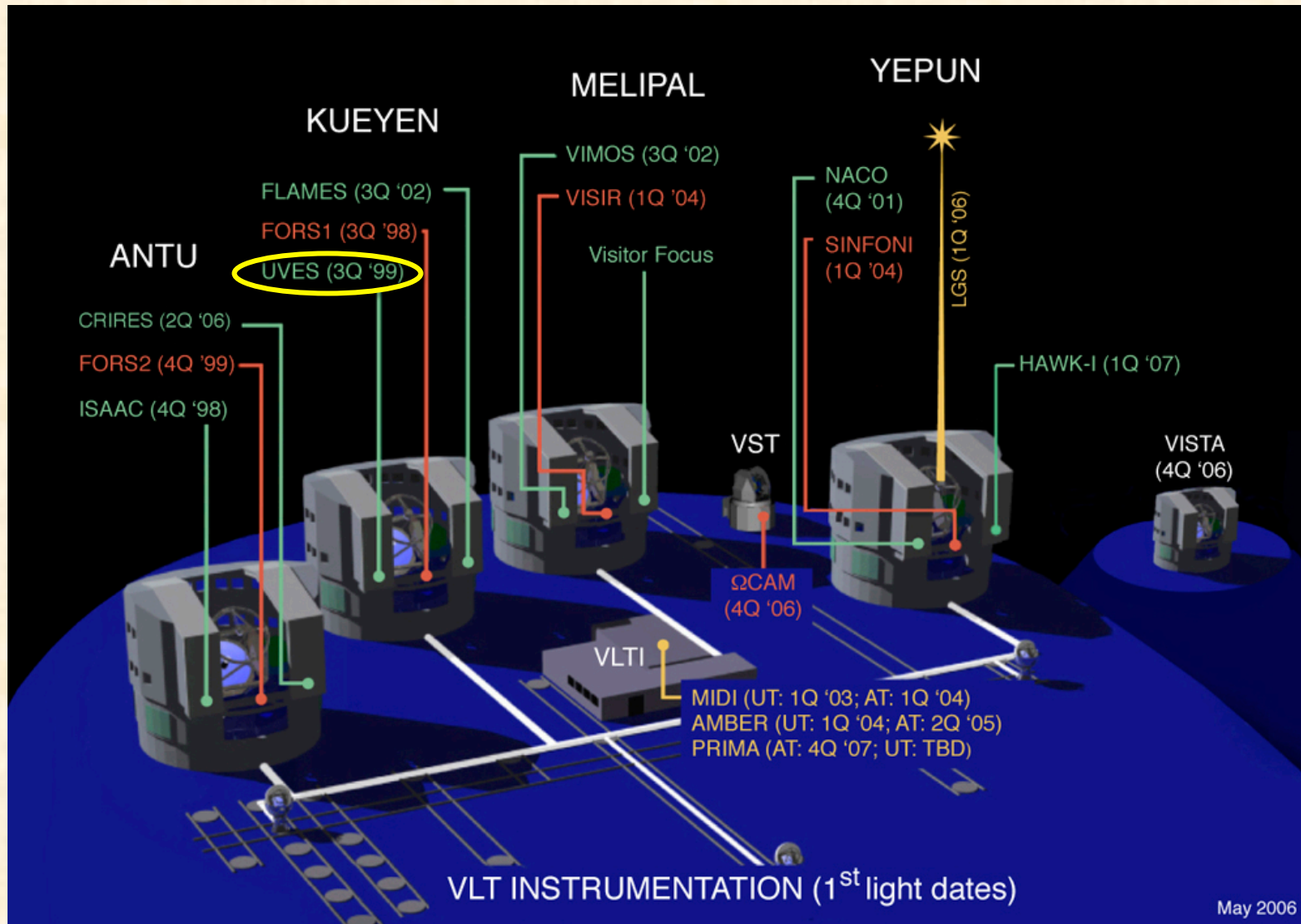

# UVES@VLT

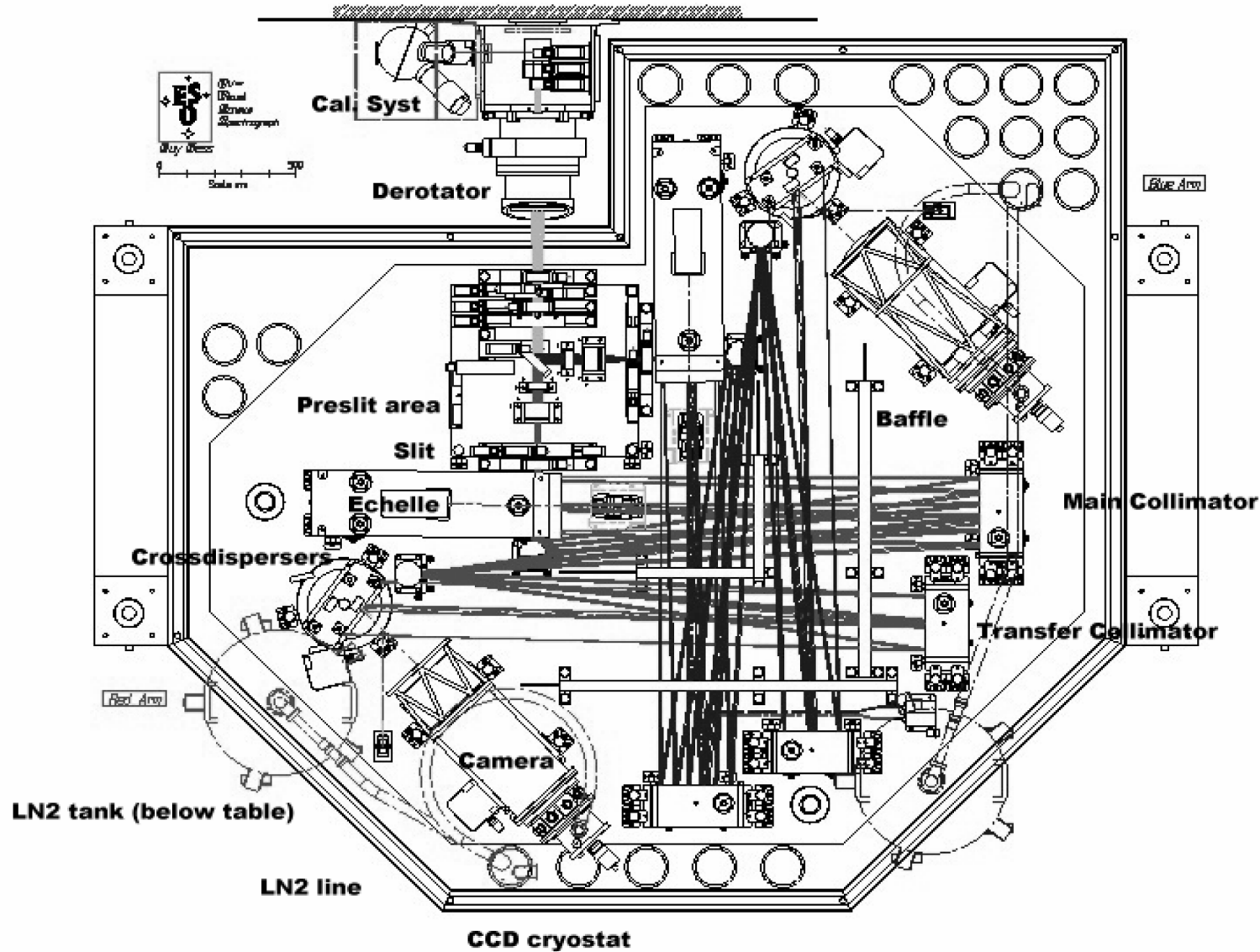



# UVES

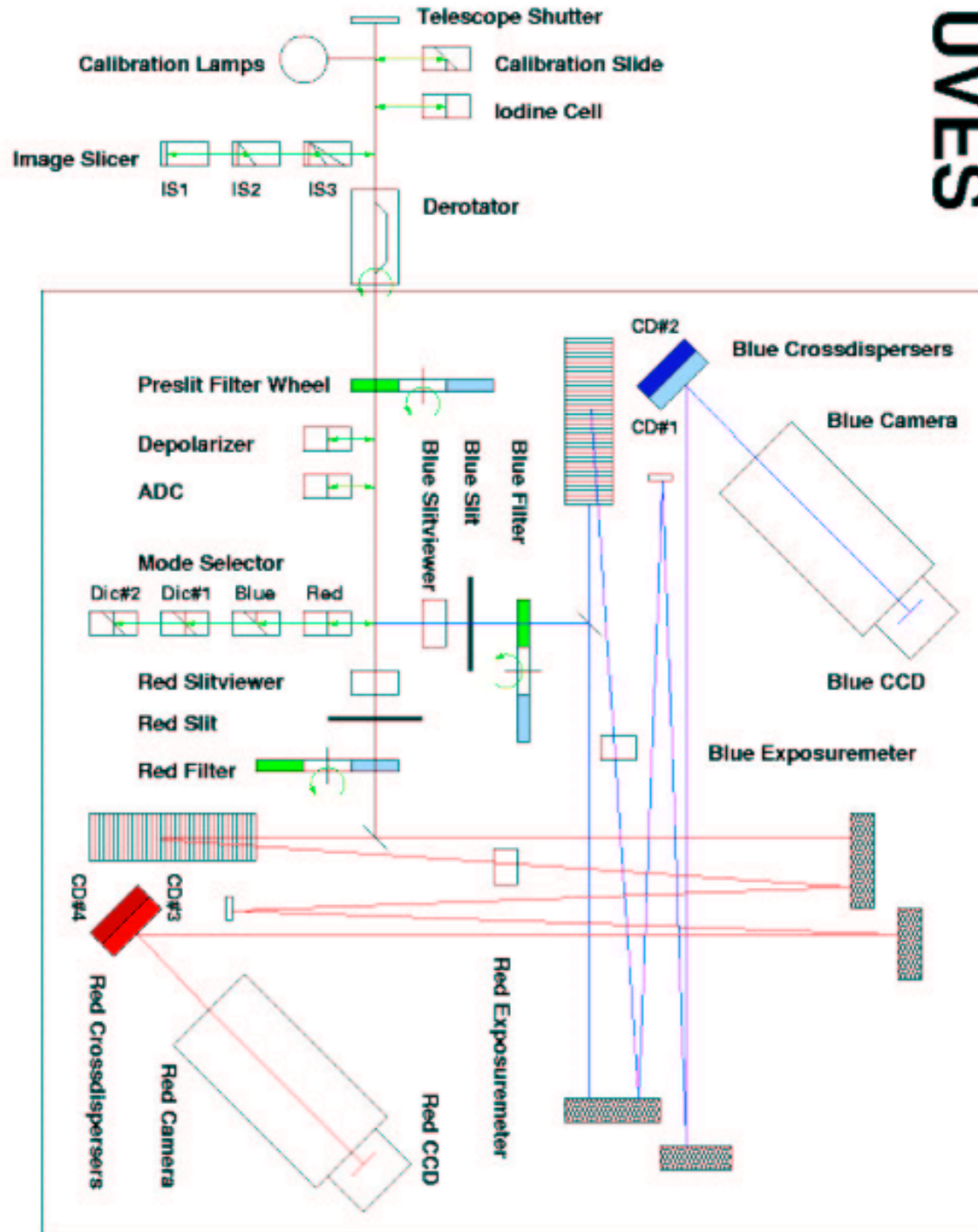

# UVES@VLT

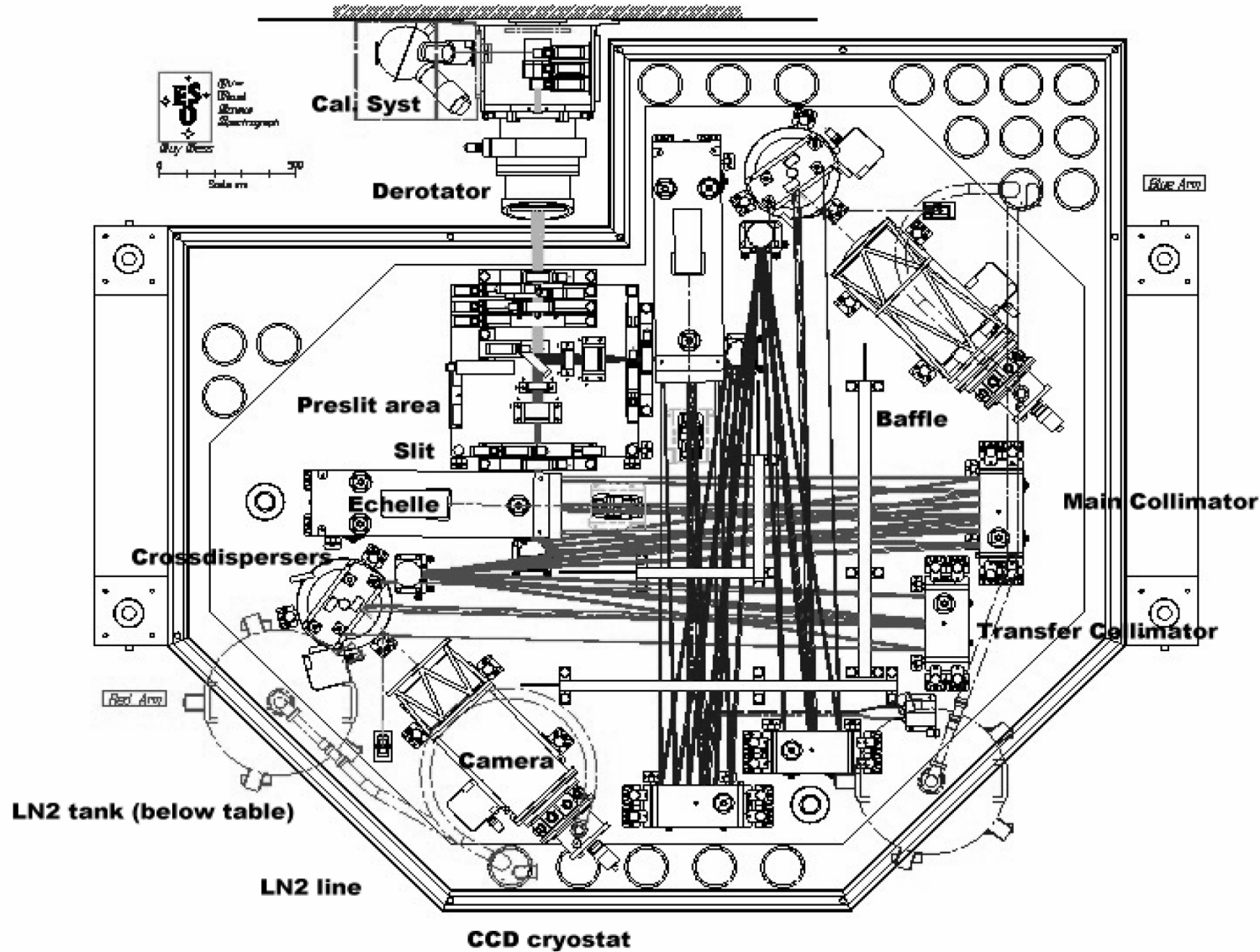

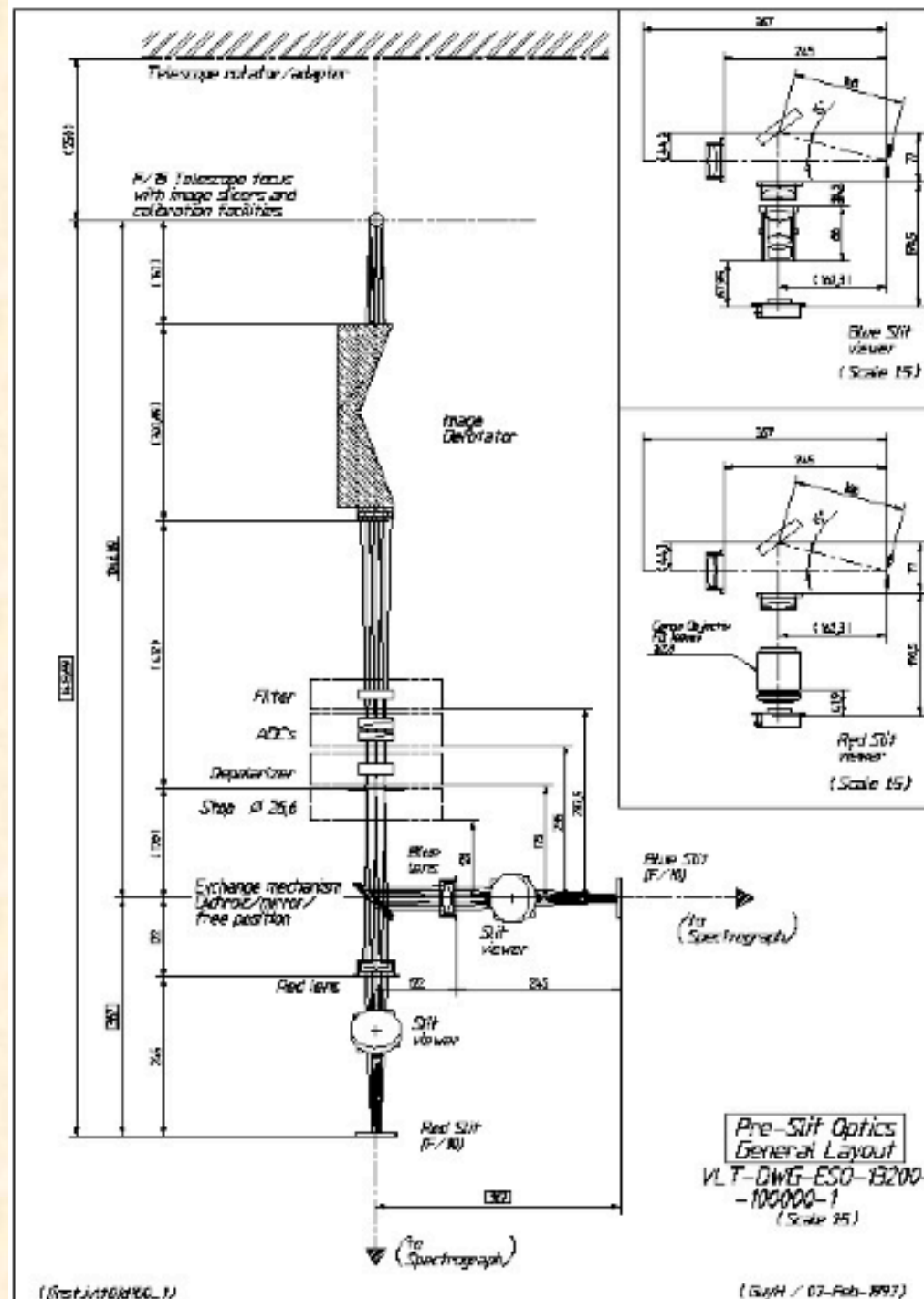

# UVES: Spectral format

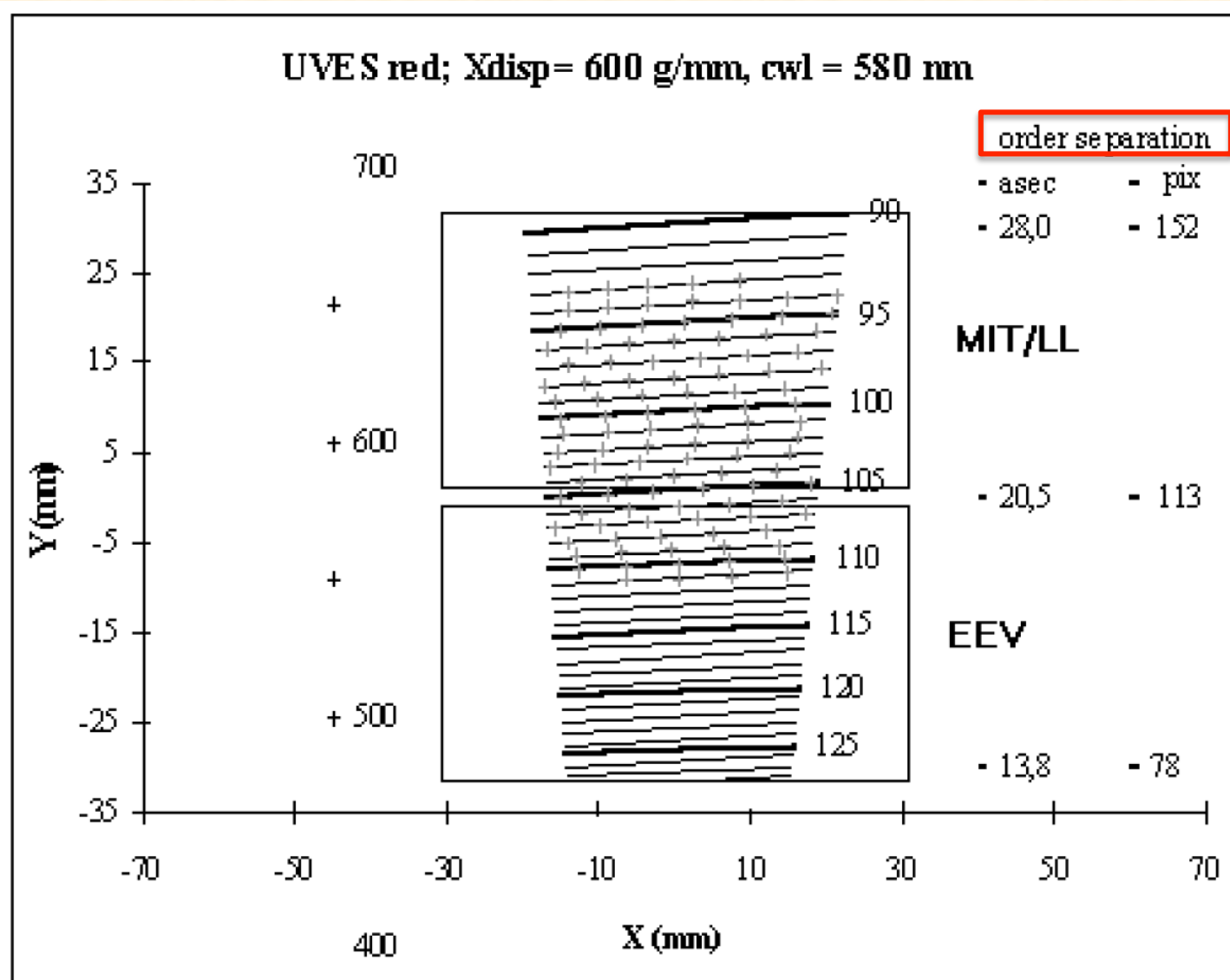

# UVES: Order separation

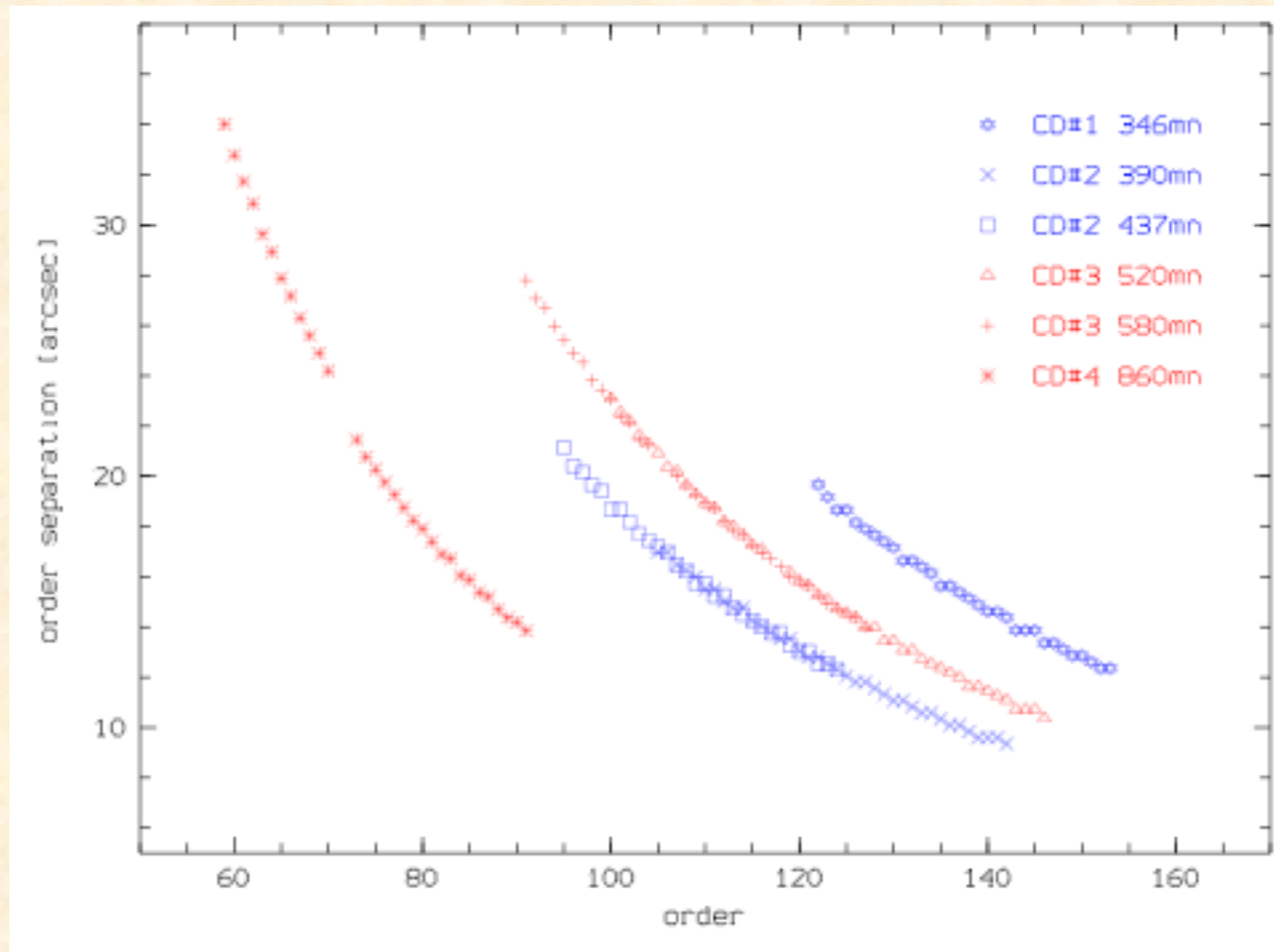

# UVES: Spectral resolution

- Telescope diameter:  $D_T = 8.2$  m
- Source/seeing/slit:  $s_{sky} = 0.3$  arcsec
- Collimated beam of the spectrograph:  $D_1 = 200$  mm

Echelle grating: R4  $\rightarrow \tan\beta = 4$ ,  $D_1 = 200$  mm

$$D_{echelle} = \frac{d\beta}{d\lambda} = \frac{2 \tan\beta}{\lambda} = \frac{8}{0.55} = 14.5 \text{ rad}/\mu\text{m}$$

$$R_{UVES} = \frac{\lambda}{\delta\lambda} = \lambda \cdot \frac{D_1}{D_T} \cdot \frac{D_{prism}}{s_{sky}} = 0.55 \cdot \frac{0.2}{8.2} \cdot \frac{14.5}{0.3 \cdot 5 \cdot 10^{-6}} \approx 130'000$$

# UVES: Sampling and resolution

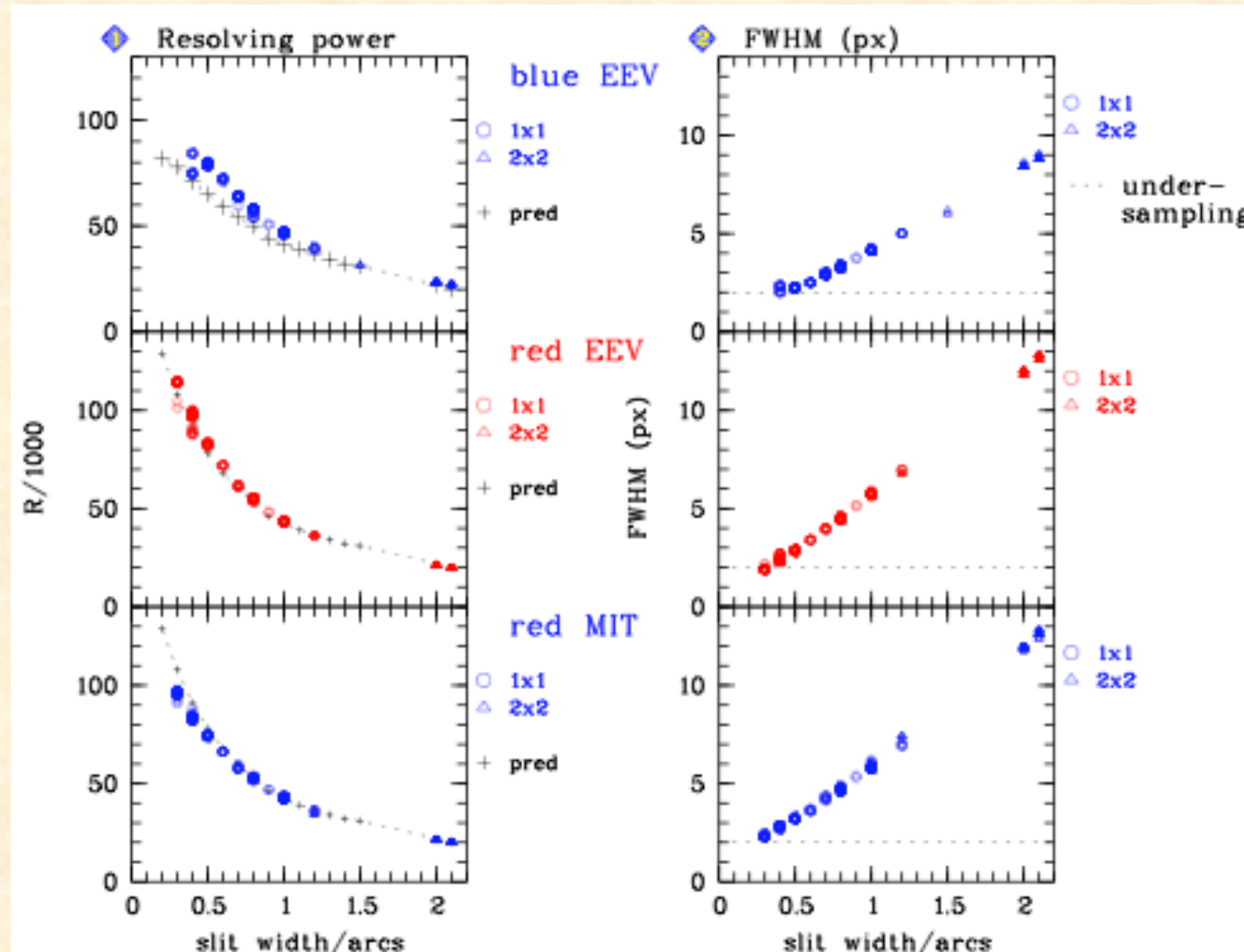

# UVES: Image slicer 'trick'

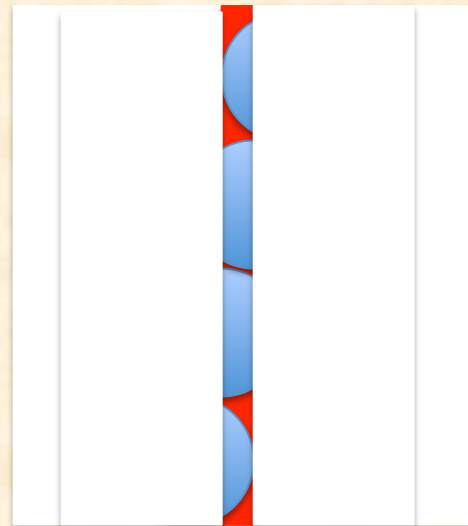
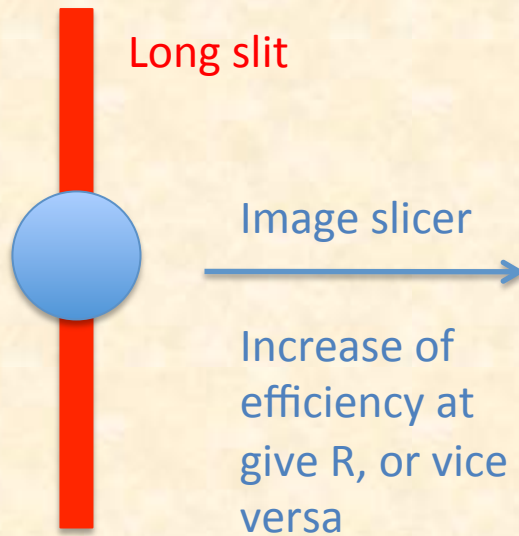

Slicer	Entrance	Slit	$N_{slicers}$
1	2.1x2.6"	0.68x7.9"	3
2	1.8x2.0"	0.44x7.9"	4
3	1.5x2.0"	0.30x10.0"	5

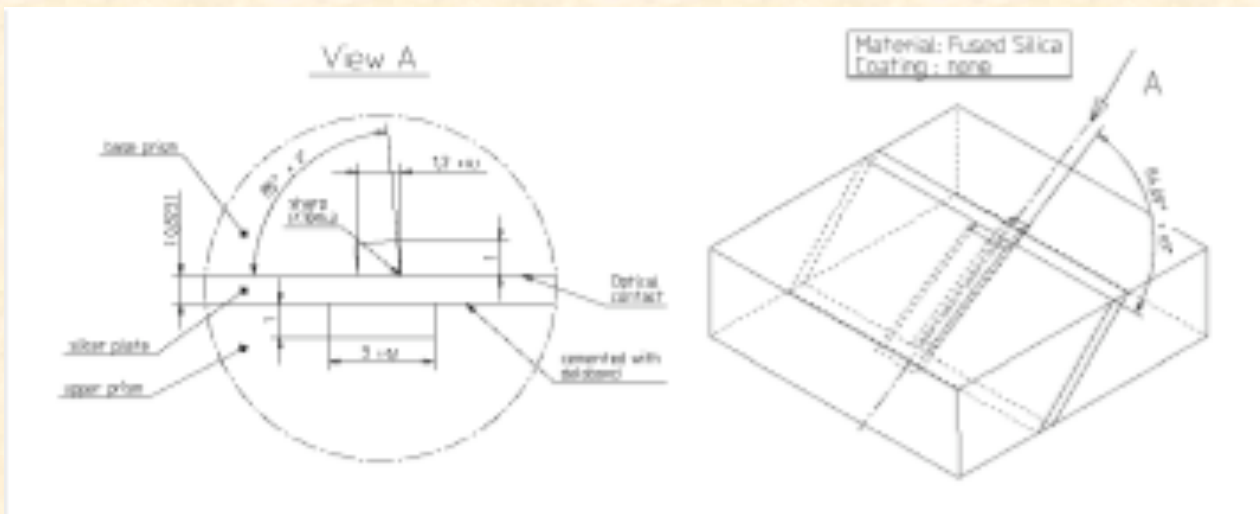



# UVES params

	Blue	Red
Wavelength range	300 - 500 nm	420 - 1100 nm
Resolution-slit product	41,400	38,700
Max. resolution	~80,000 (0.4" slit)	~110,000 (0.3" slit)
Limiting magnitude (1.5hr integration, S/N=10, seeing 0.7")	18.0 at R=58,000 in U (0.7" slit)	19.5 at R=62,000 in V (0.7" slit)
Overall detective quantum efficiency (DQE) (from the top of the telescope, wide slit)	12% at 400 nm	14% at 600 nm
Camera	dioptric F/1.8, 70 $\mu\text{m}/\text{arcsec}$ field 43.5 mm diam.	dioptric F/2.5, 97 $\mu\text{m}/\text{arcsec}$ field 87 mm diam.
CCDs (pixel scale)	EEV, 2Kx4K, 15 $\mu\text{m}$ pixels (0.22 arcsec/pix)	mosaic of two (EEV + MIT/LL), 2Kx4K, 15 $\mu\text{m}$ pixels (0.16 arcsec/pix)
Echelle	41.59 g/mm, R4 mosaic	31.6 g/mm, R4 mosaic
Crossdispersers: g/mm and wavelength of max. efficiency	#1: 1000 g/mm, 360 nm #2: 660 g/mm, 460 nm	#3: 600 g/mm, 560 nm #4: 312 g/mm, 770 nm
Typical wavelength range/frame [CD#1(#2) and CD#3(#4)]	85 (126) nm in 33 (31) orders	200 (403) nm in 37 (33) orders
Min. order separation	10 arcsec or 40 pixels	12 arcsec or 70 pixels

# UVES: Efficiency

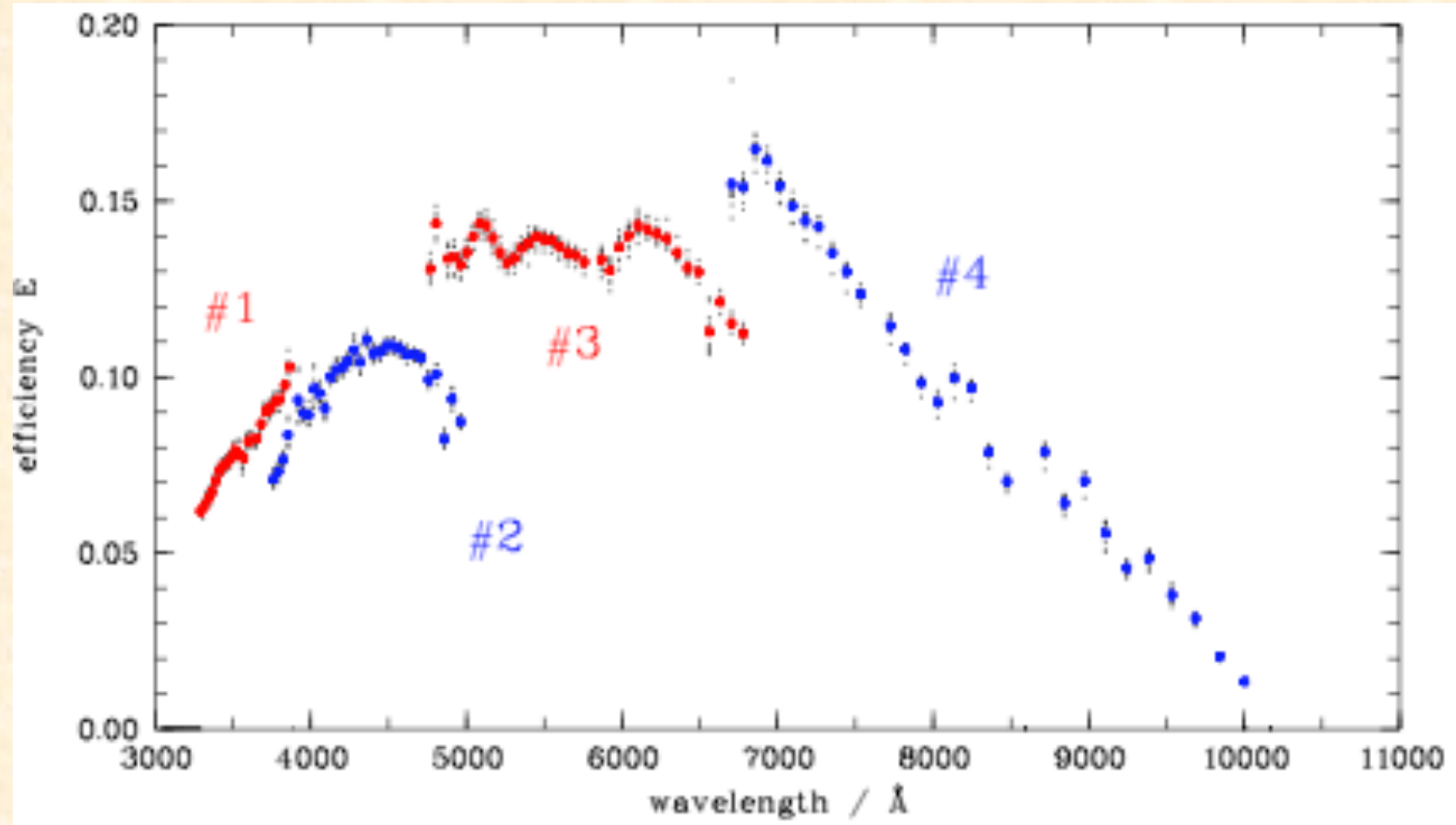

# CRIRES@VLT

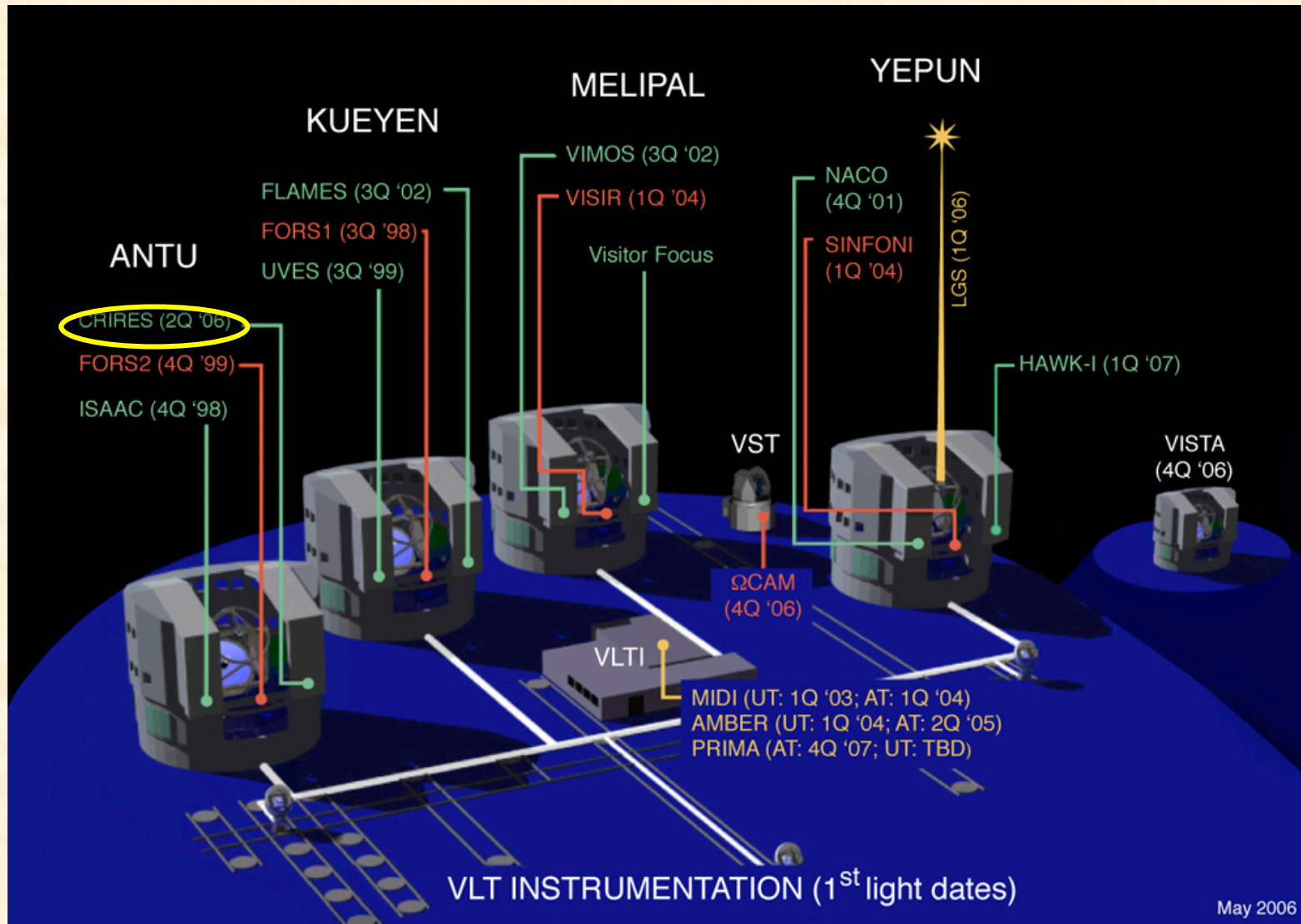

# CRIRES@VLT

## CRIRES

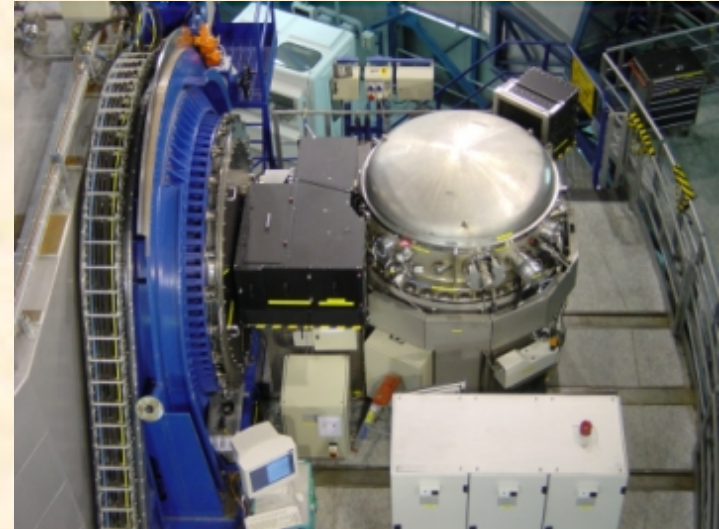
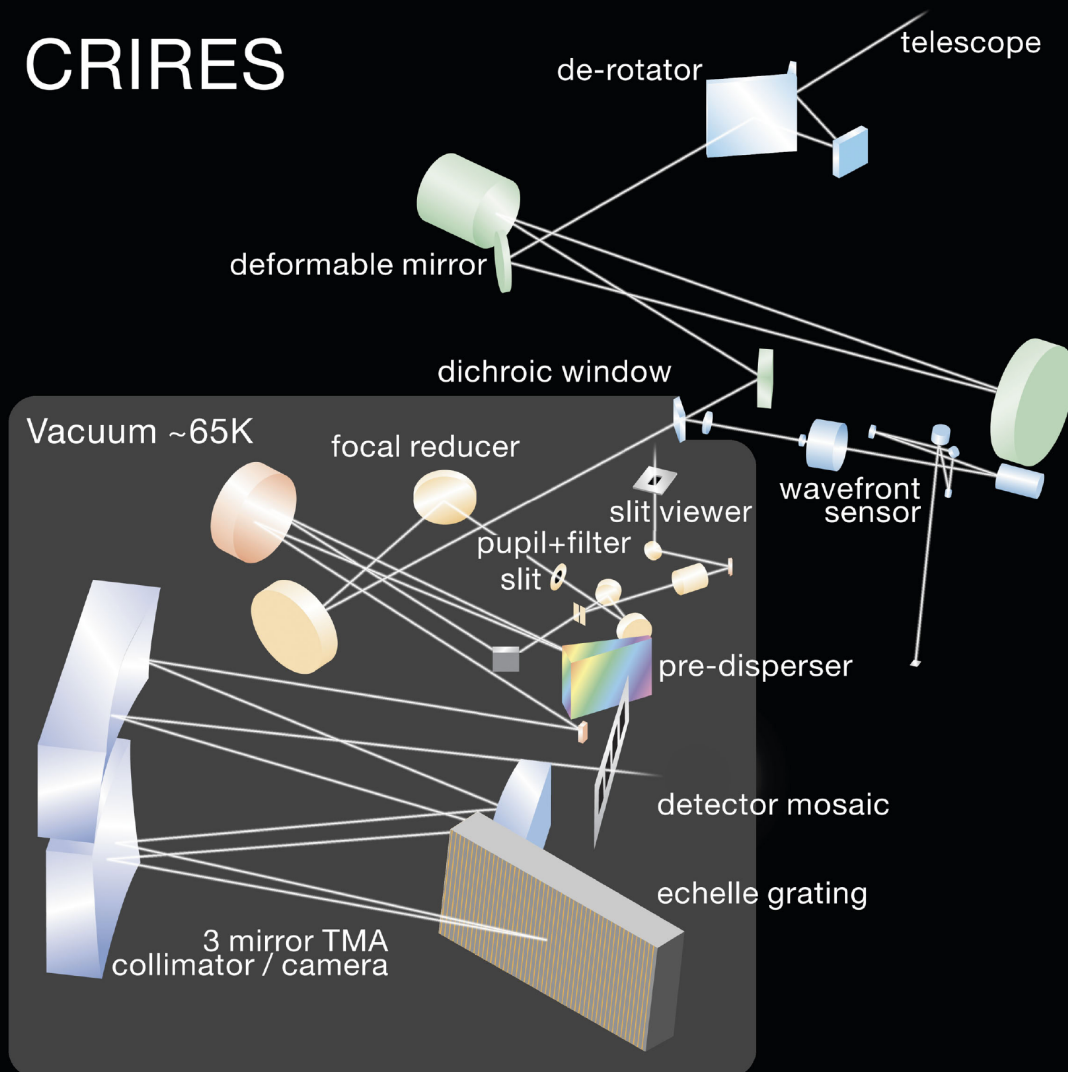

Same as UVES, but:

- For IR ( $\lambda = 1 - 5.4 \mu\text{m}$ )
- Can use adaptive optics
- Cryogenics needed
- No cross-disperser. Only 1 order at a time!  
-> Pre-disperser

# CRIRES@VLT, AO

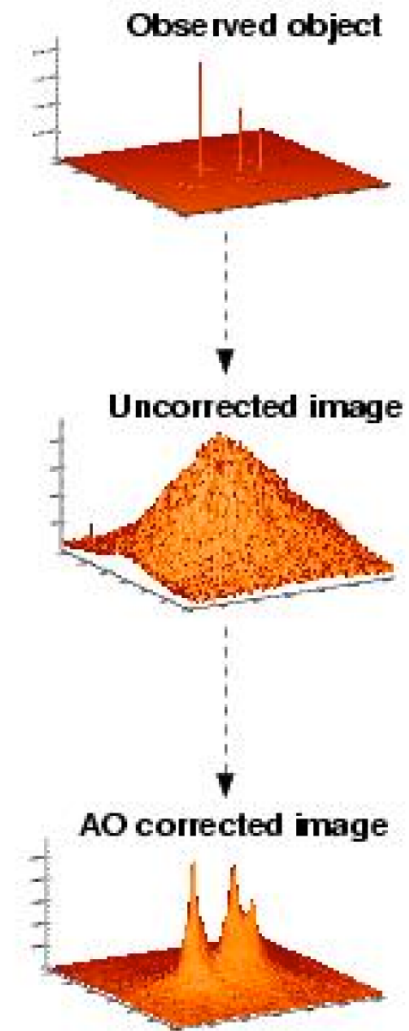
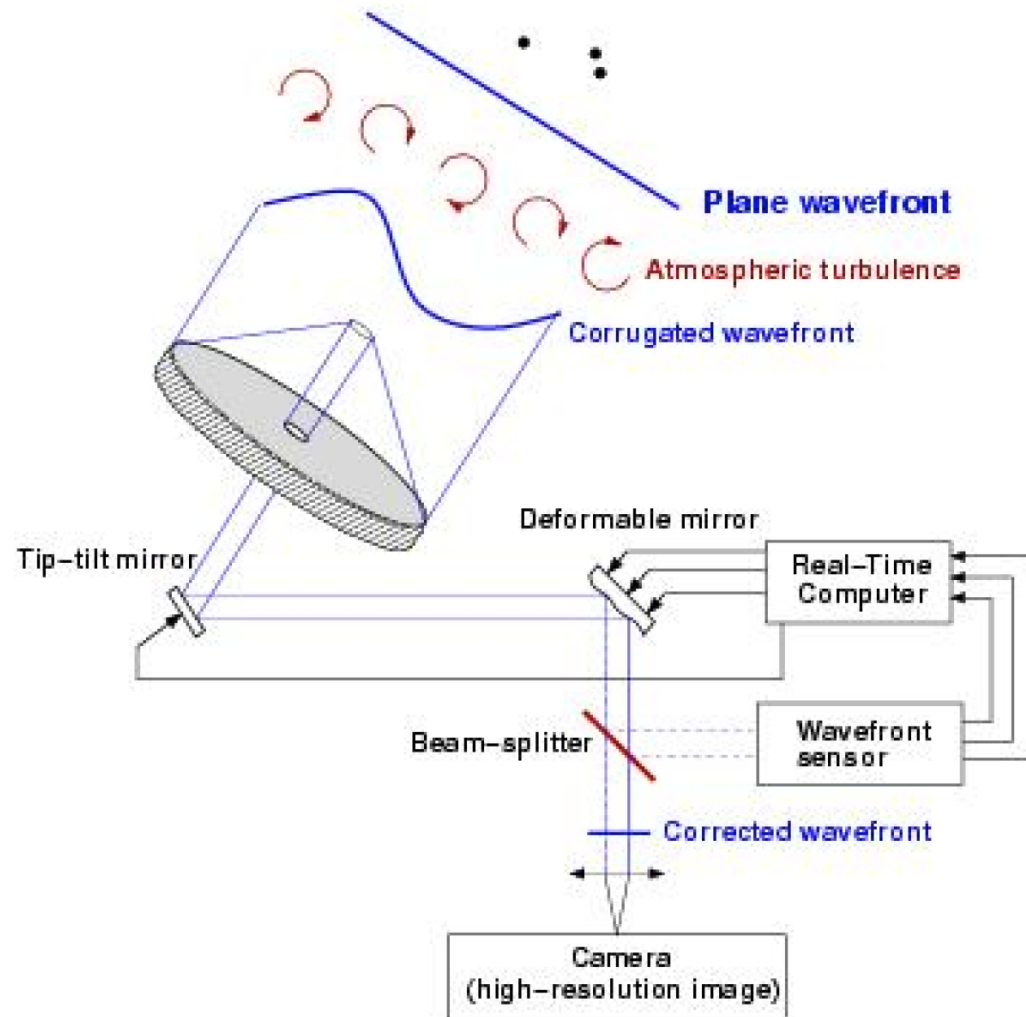

# CRIRES: Characteristics

---

Calibration system	halogen lamp, IR-emitter, ThAr, N <sub>2</sub> O and CO gas cells
Adaptive optics	60-actuator curvature sensing MACAO system
Slit length	≈ 31 "
Slit width	0.05 " – 3.0 ": recommended 0.2 " – 0.4 "
Echelle grating	40 × 20cm, 31.6 lines/mm, 63.5° blaze angle
Resolving power	100,000 (0.2 "); 50,000 (0.4 " slit)
Wavelength range	0.95μm ≤ λ ≤ 5.4μm
Free spectral range	λ/70
Detector science array	4096 × 512 pixels using 4 Aladdin III detectors
Pixel scale	0.086 "
Slit viewer: filters	J, H, K + 2 H neutral density
Slit viewer: detector	Aladdin III array
Slit viewer: field-of-view	≈ 36 " × 43 "
Slit viewer: pixel scale	≈ 0.045 "
Pre-disperser	ZnSe prism

---

---

# CRIRES: Spectral format

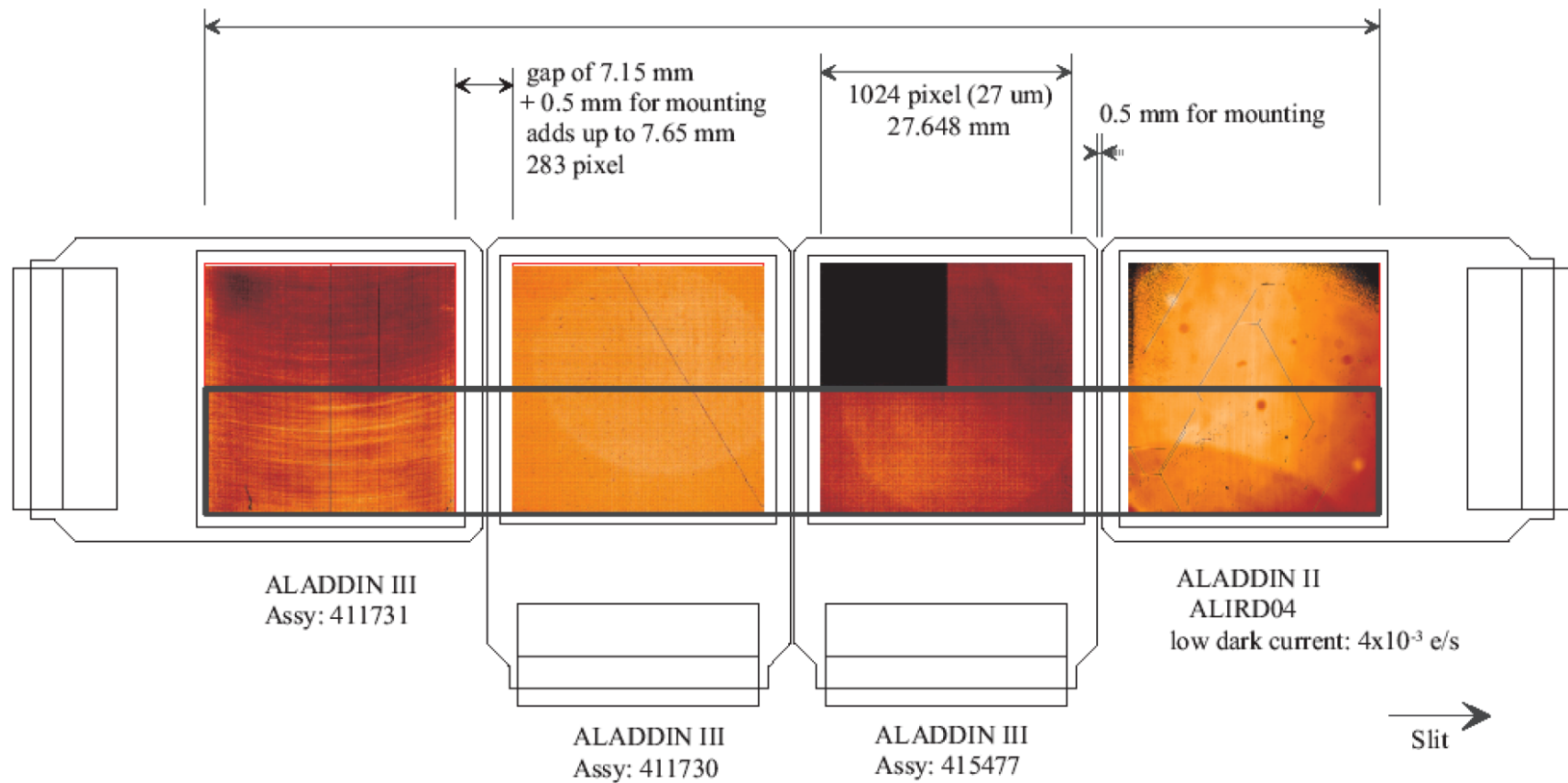

# CRIRES: Long slit

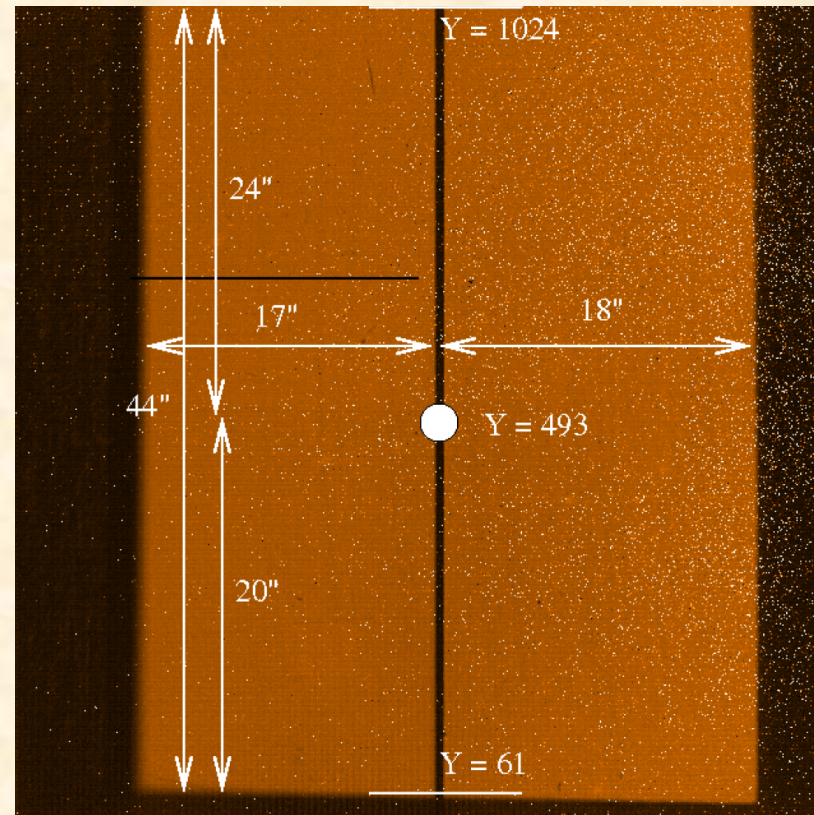
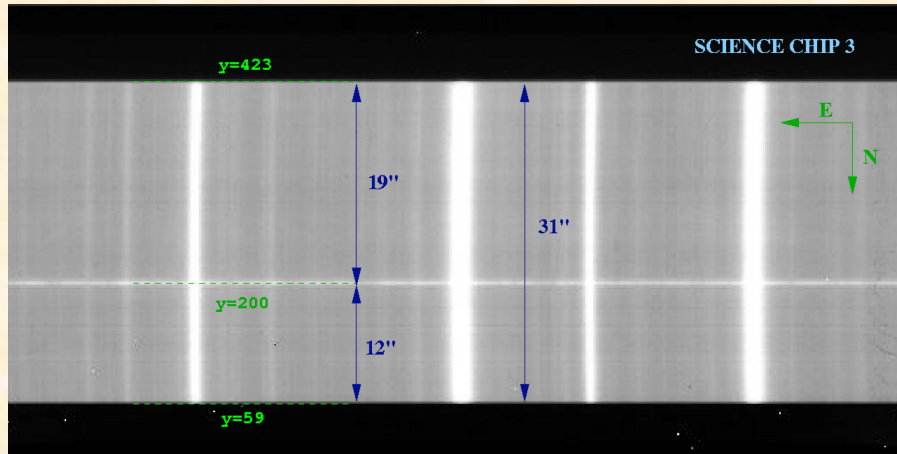



# CRIRES@VLT

Peculiarities of the IR domain:

- Detector technology (no Si-CCDs, behavior less 'ideal' in terms of noise, flat-field stability, etc.)
- Thermal and sky back-ground -> remove e.g. by 'nodding' over long slit and put instrument 'cold'
- Atmospheric absorption and emission features
- Advantage: Use of adaptive optics to reduce slit width.

# CRIRES@VLT

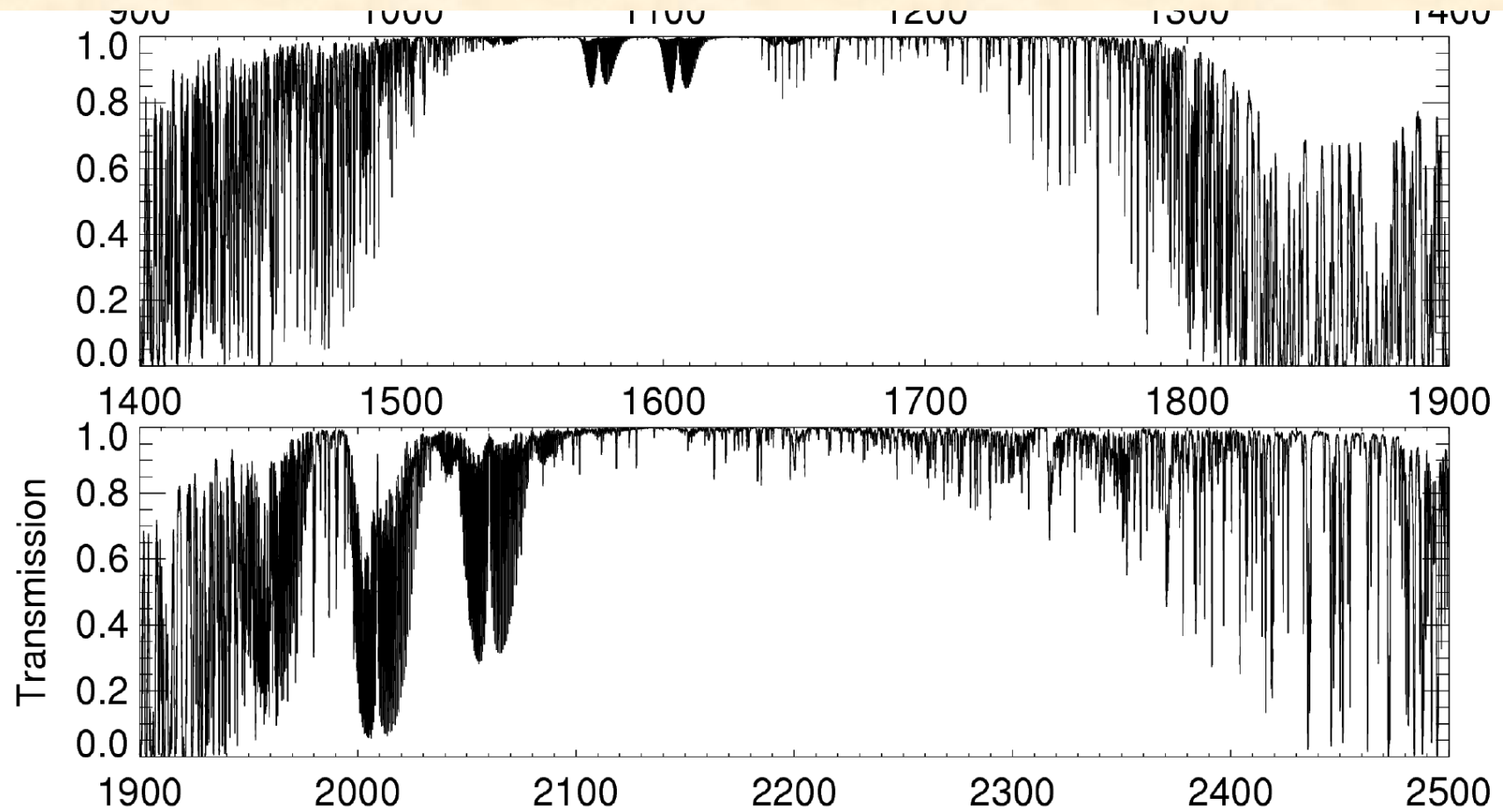

SOURCE

SPECTROGRAPHIC  
MODES

VLT  
INSTRUMENTS

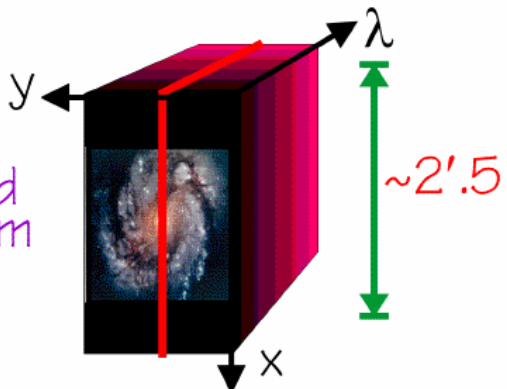
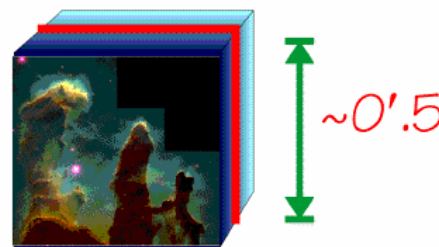
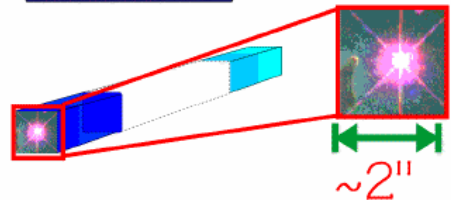
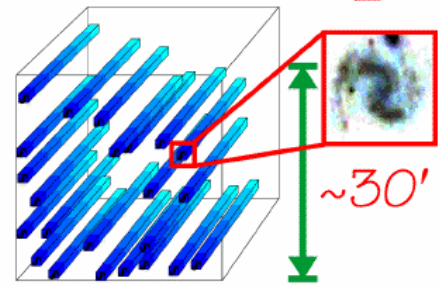
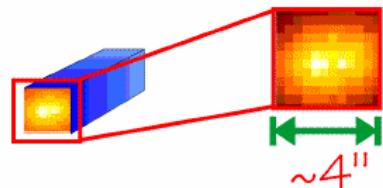
L.S.S. Extended Continuum		ISAAC FORS 1/2 CONICA VISIR
S.I.S. Extended Emission		CONICA
C.D.E.S. Single Point Continuum		UVES CRIRES
M.O.S. Diluted-Point Continuum		FORS 1/2 NIRMOS/ VIMOS GIRAFFE
I.F.S. Single Small Continuum		GIRAFFE SINFONI

SOURCE

SPECTROGRAPHIC  
MODES

VLT  
INSTRUMENTS

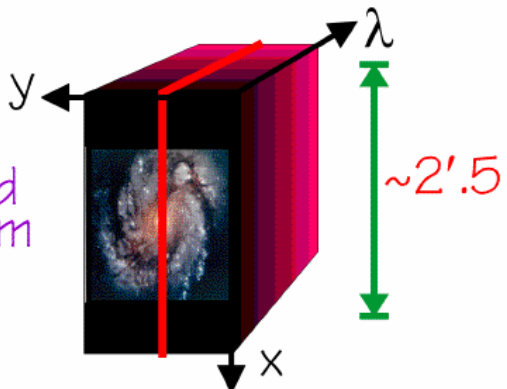
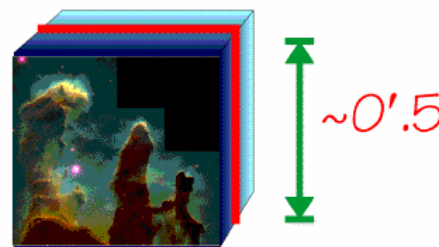
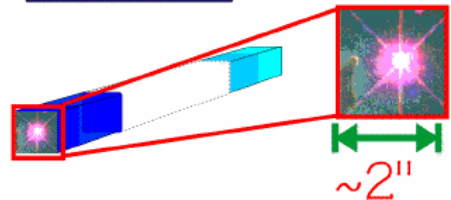
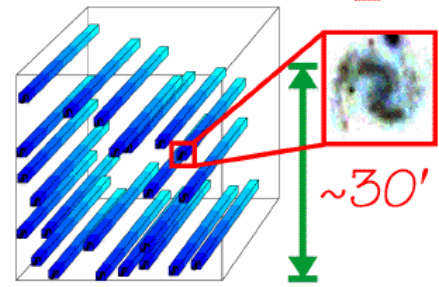
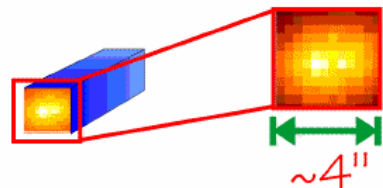
L.S.S. Extended Continuum		ISAAC FORS 1/2 CONICA VISIR
S.I.S. Extended Emission		CONICA
C.D.E.S. Single Point Continuum		UVES CRIRES
M.O.S. Diluted-Point Continuum		FORS 1/2 NIRMOS/ VIMOS GIRAFFE
I.F.S. Single Small Continuum		GIRAFFE SINFONI

# Flames@VLT

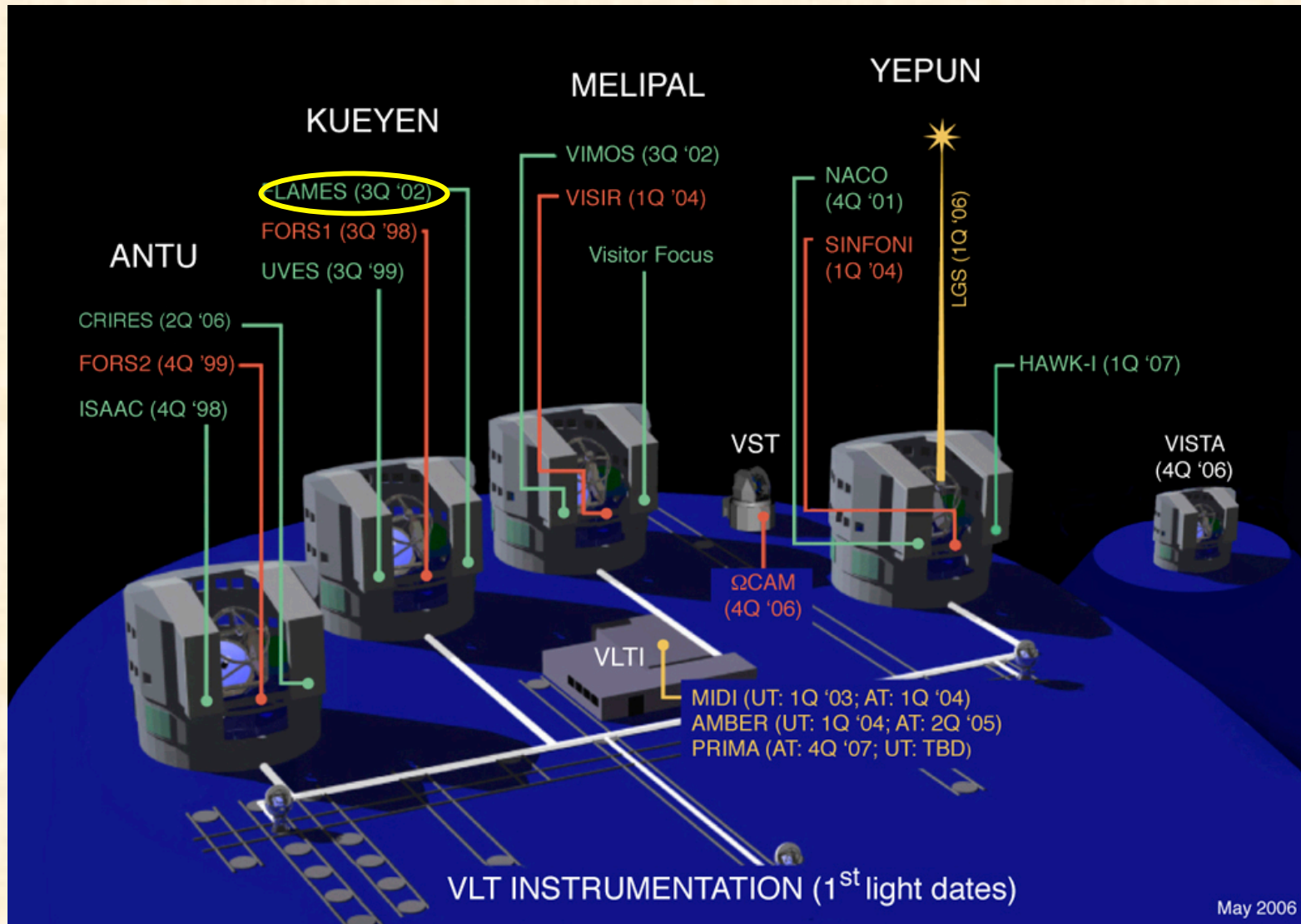

# Flames - various links

Mode	Number of Buttons	Fibers per Buttons	Sky Buttons	Total fibers
UVES	8	UVES	1 - 8	
Medusa	132		1 - 132	
IFU	15		20	15
ARGUS	1	Giraffe	14x22 (-8)	15

# Flames - UVES link

Mode	Number of Buttons	Fibers per Buttons	Sky Buttons	Total fibers
UVES	8	1	- 8	
Medusa	132	1	- 132	
IFU	15	20	15	315
ARGUS	1	14x22 (-8)	15	315

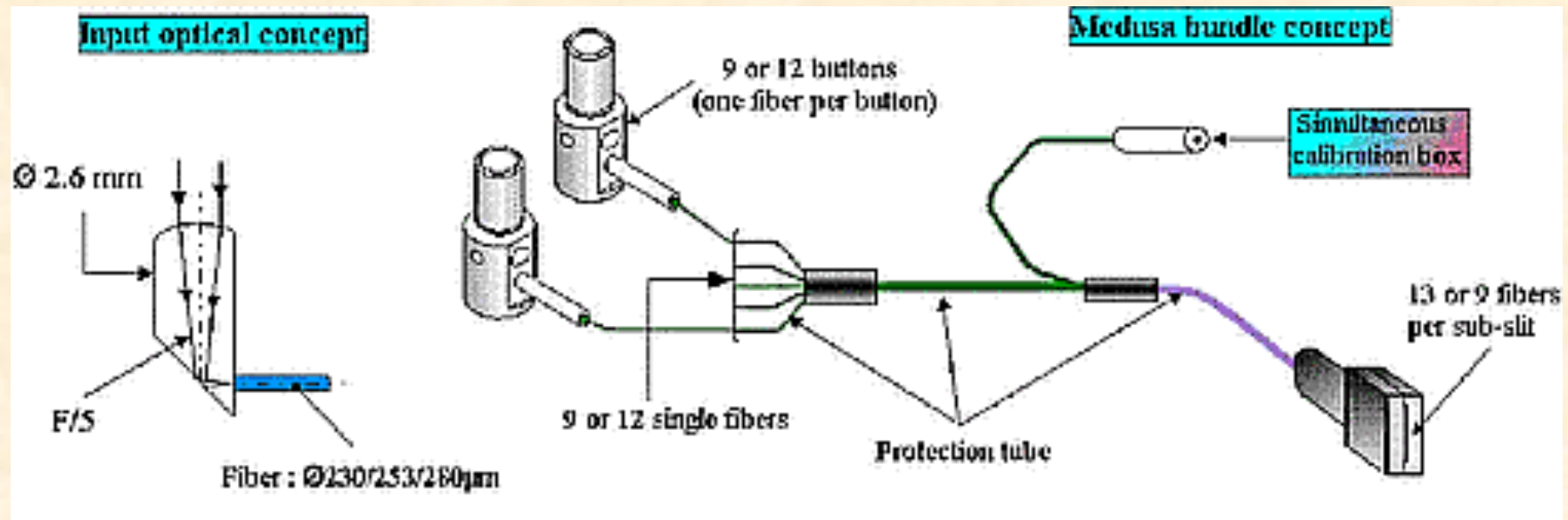

# Flames - UVES link

Mode	Number of Buttons	Fibers per Buttons	Sky Buttons	Total fibers
UVES	8	1	- 8	
Medusa	132	1	- 132	
IFU	15	20	15	315
ARGUS	1	14x22 (-8)	15	315

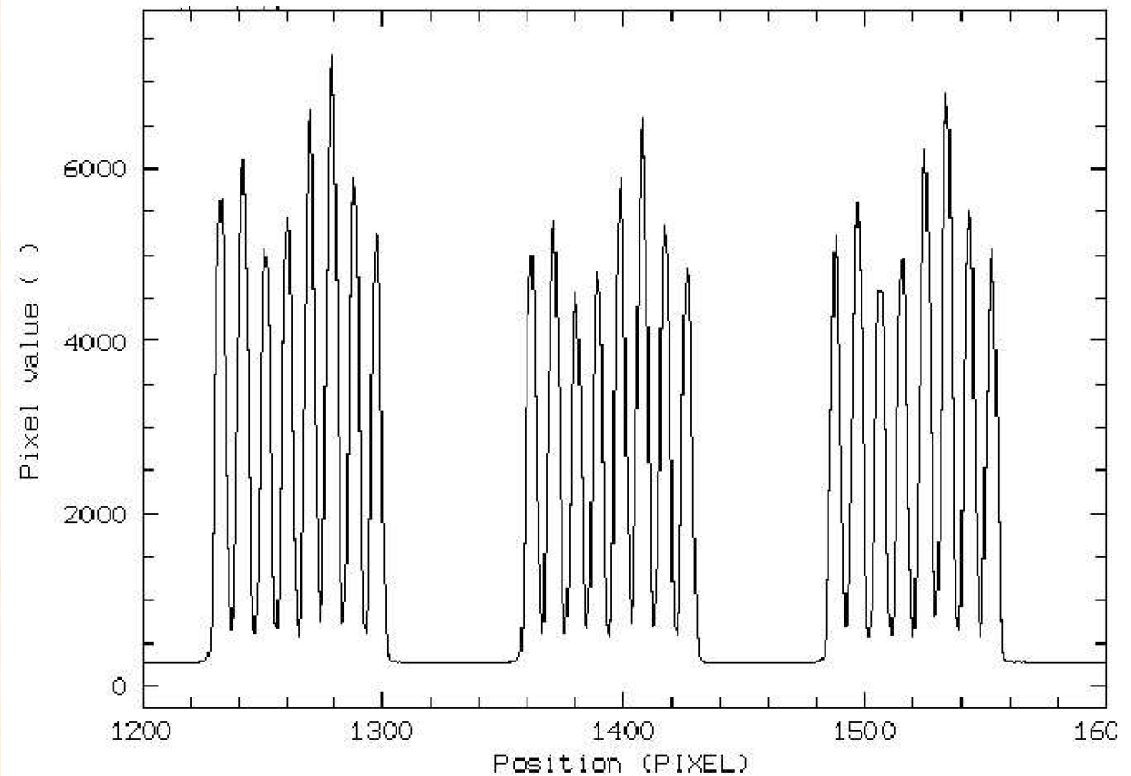
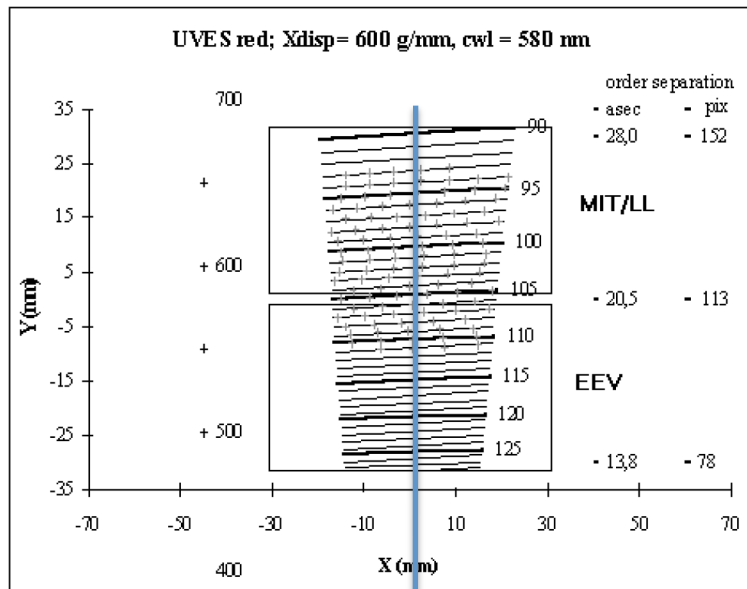



# Flames - Giraffe

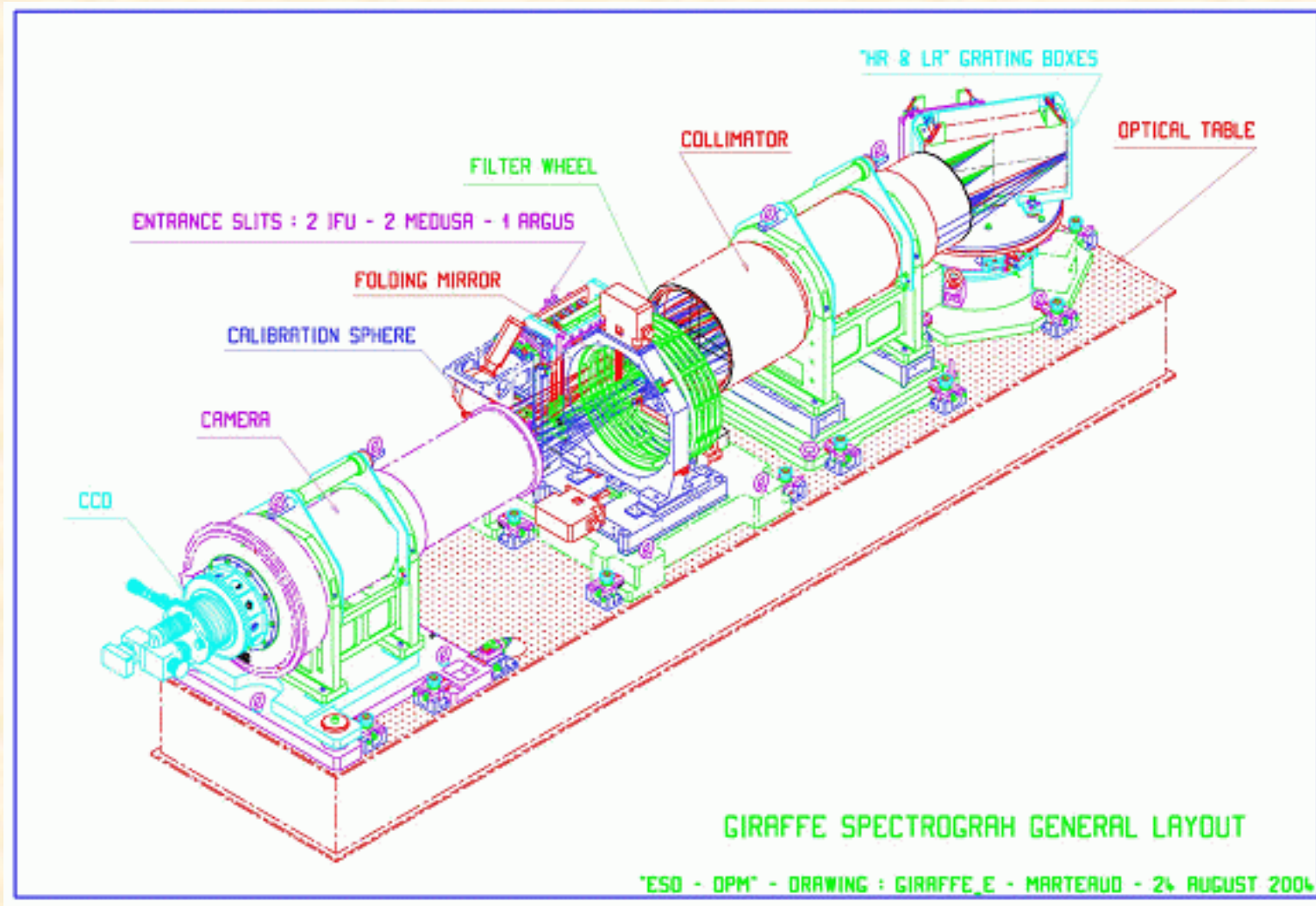

# Flames - MEDUSA

Mode	Number of Buttons	Fibers per Buttons	Sky Buttons	Total fibers
UVES	8	1	- 8	
Medusa	132	1	- 132	
IFU	15	20	15	315
ARGUS	1	14x22 (-8)	15	315

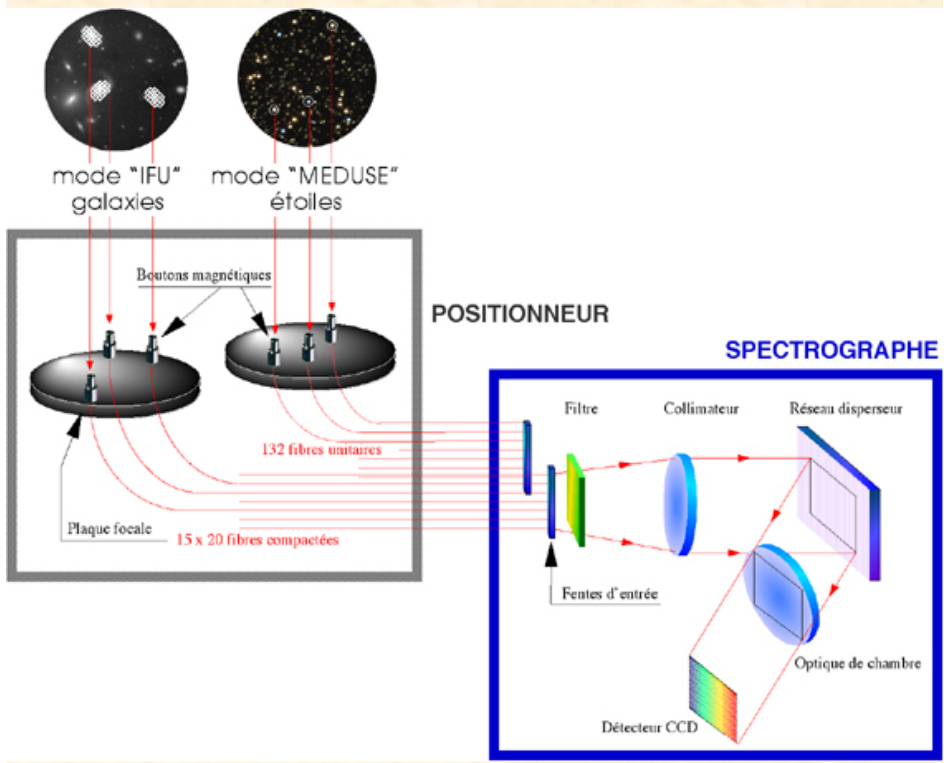
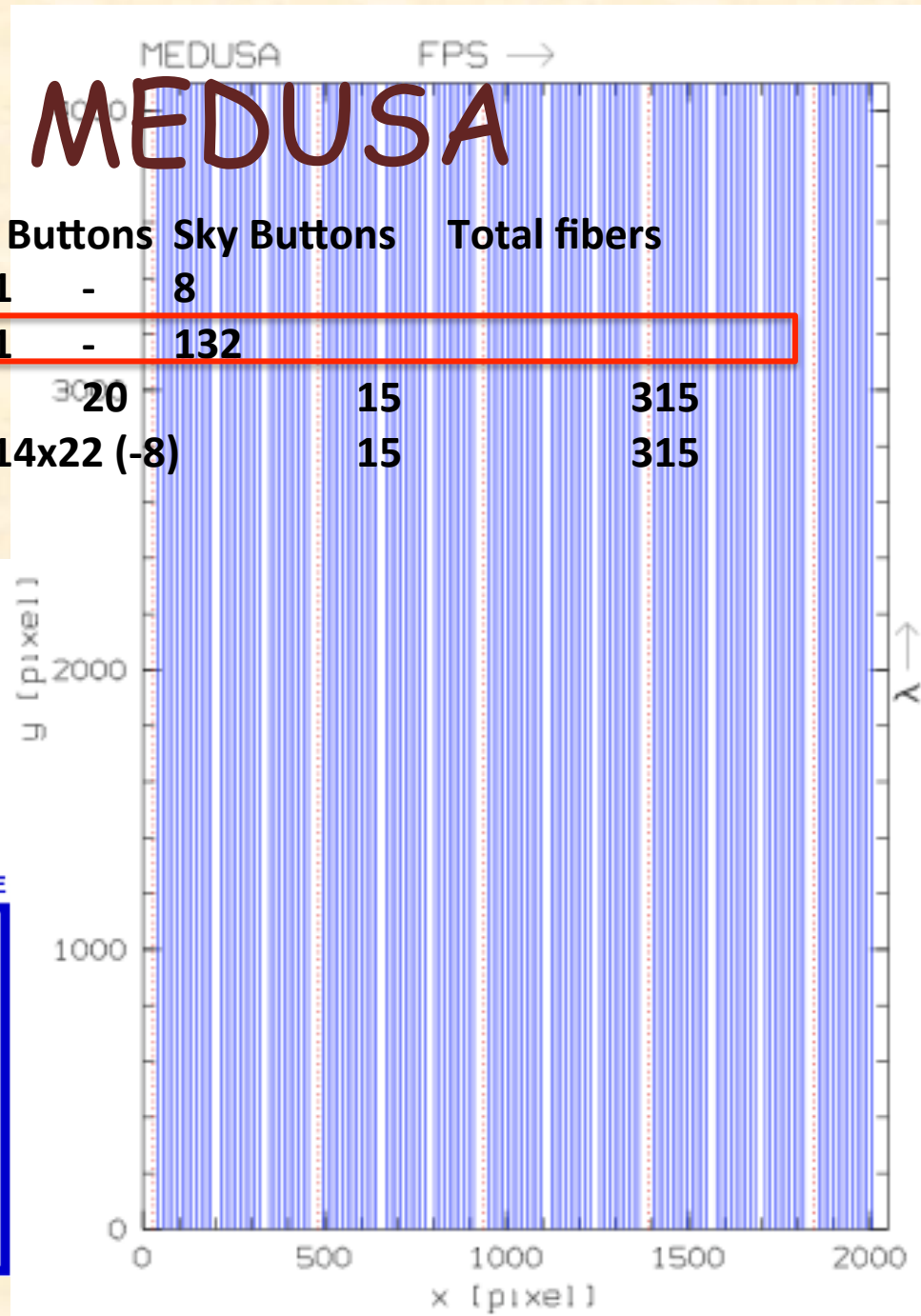

# Flames - MEDUSA



OzPoz fiber positioner

# Flames - MEDUSA

Mode	Number of Buttons	Fibers per Buttons	Sky Buttons	Total fibers
UVES	8	1 -	8	
Medusa	132	1 -	132	
IFU	15	20	15	315
ARGUS	1	14x22 (-8)	15	315

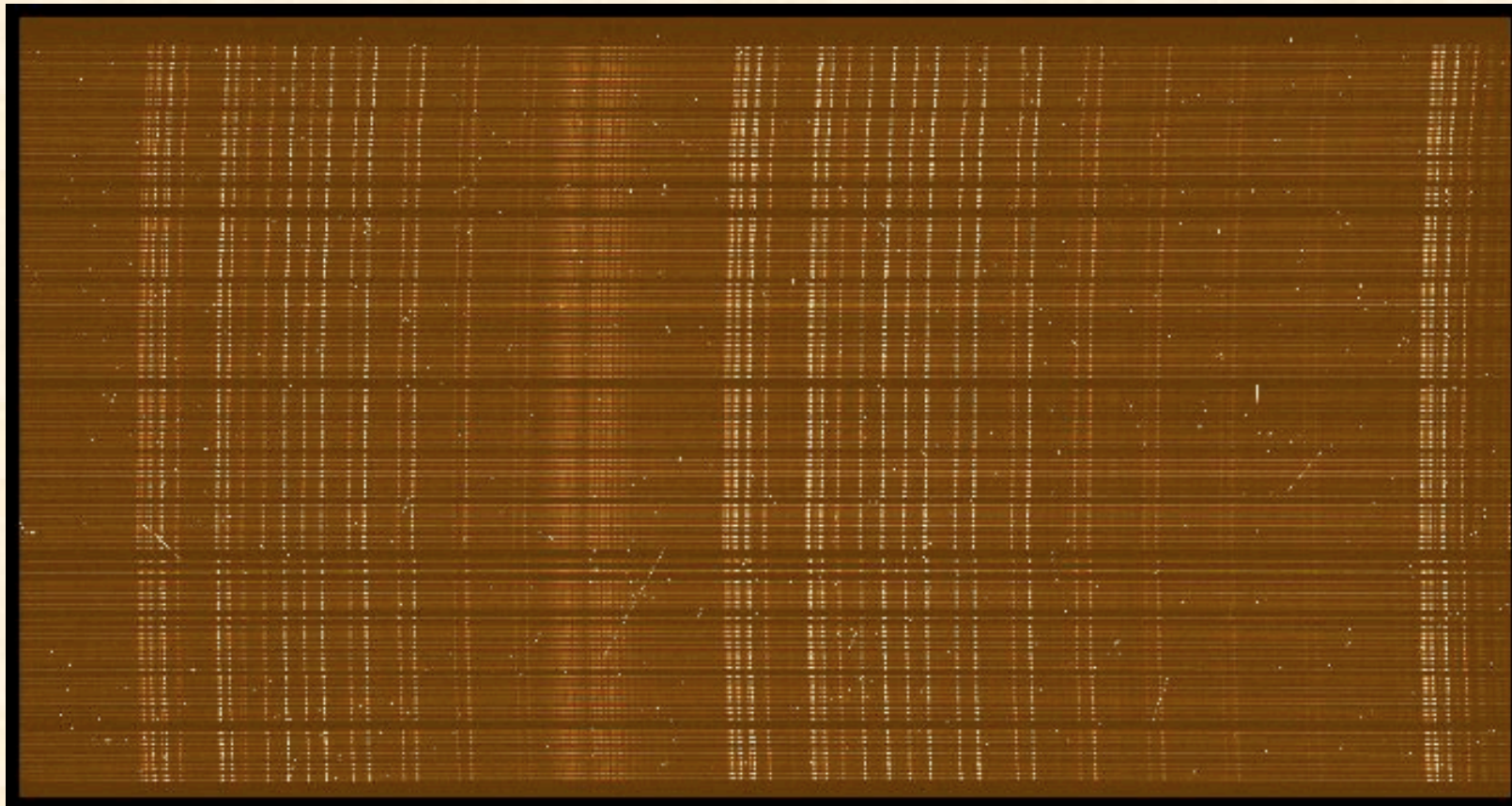

# Flames - IFU

Mode	Number of Buttons	Fibers per Buttons	Sky Buttons	Total fibers
UVES	8	1	- 8	8
Medusa	132	1	- 132	132
IFU	15	20	15	315
ARGUS	1	14x22 (-8)	15	315

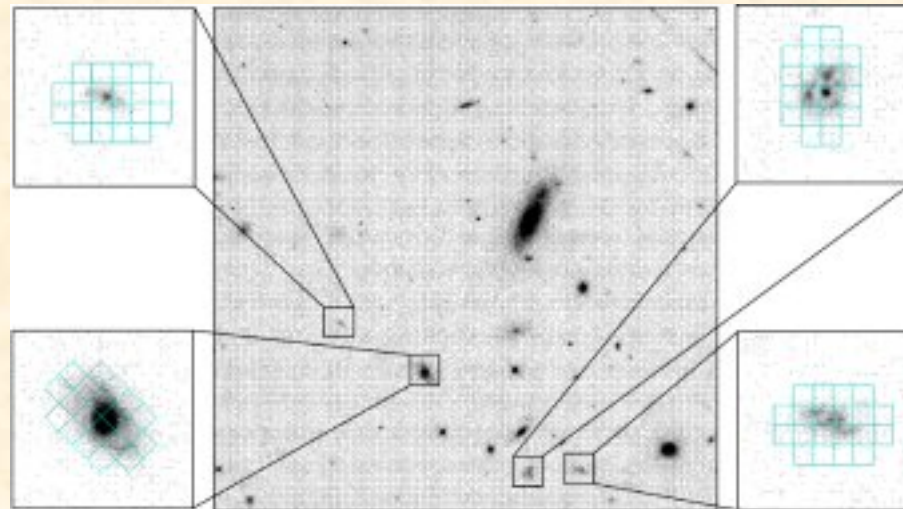

Observation with Integral Field Units at FLAMES  
(Simulation)

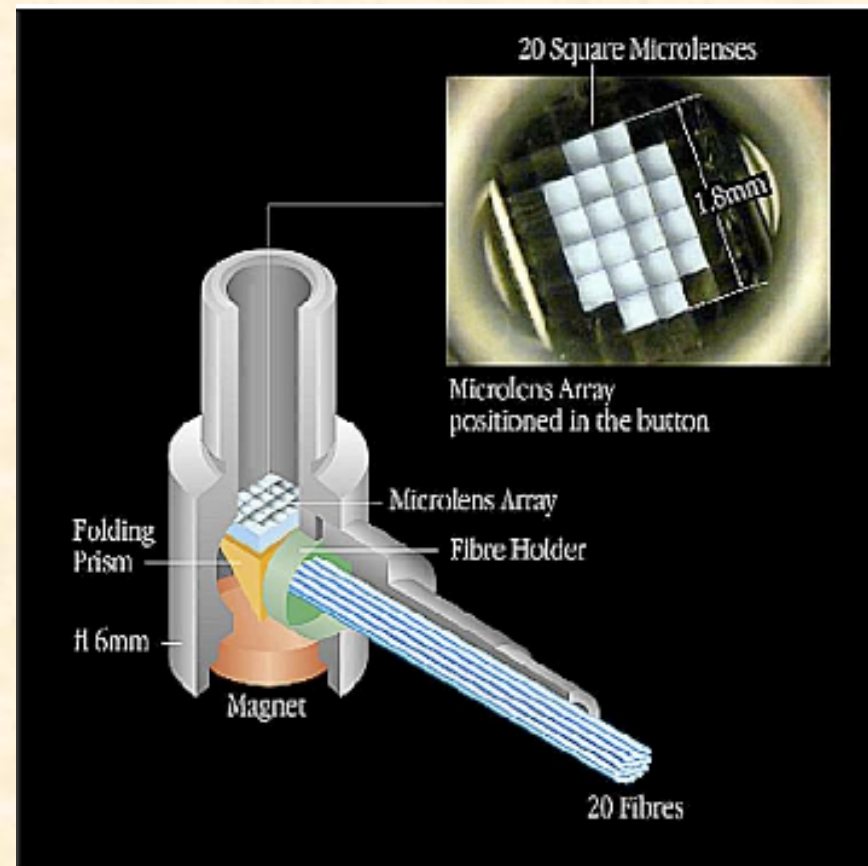

# Flames - IFU

IFU configuration shown for PA=0 deg.

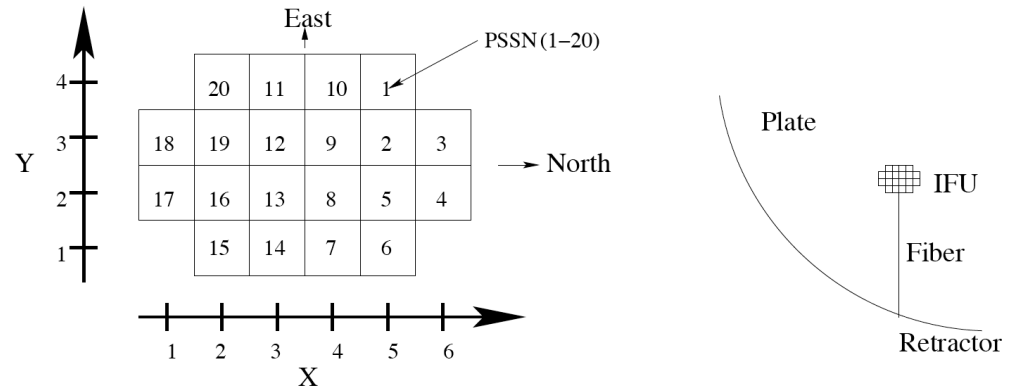

- Notes:
- 1) Position Angle PA = 315 deg – ORIENT in binary OzPoz table. PA=North–East.
  - 2) For IFUs with SKY fibers, the PSSN numbers should be increased by 1.
  - 3) X,Y and PSSN can be found in the binary FLAMES FIBER table.

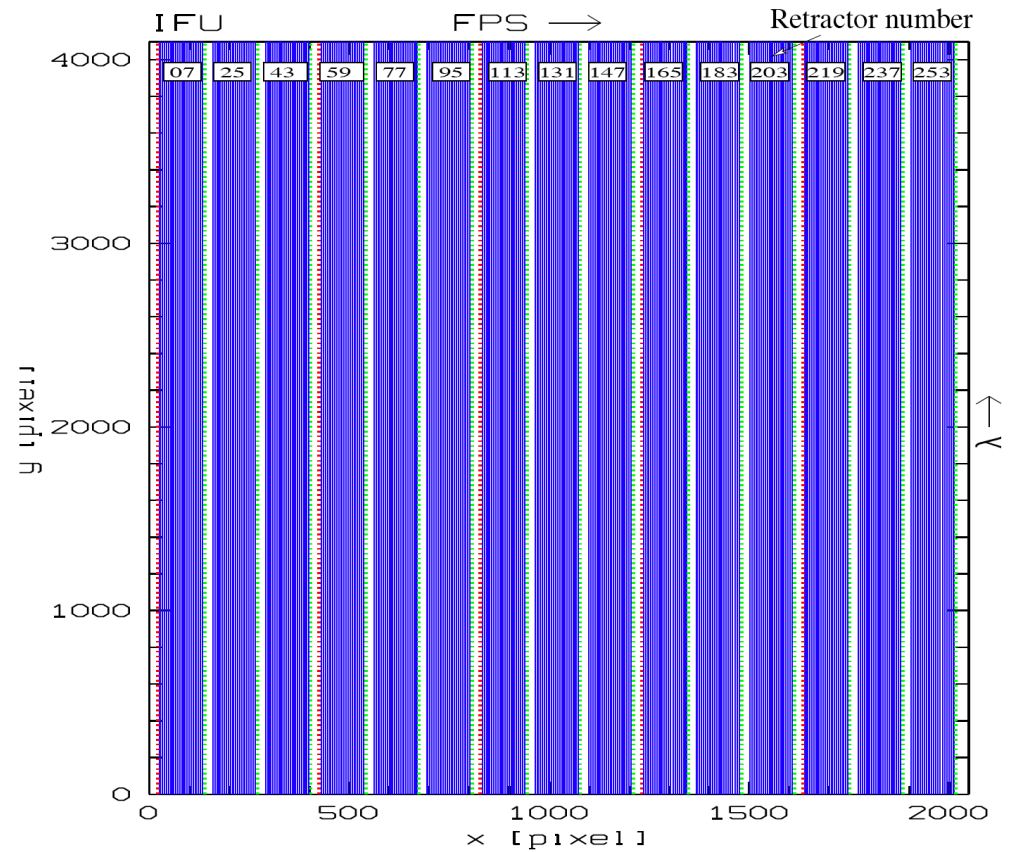

# Flames - ARGUS

Mode	Number of Buttons	Fibers per Buttons	Sky Buttons	Total fibers
UVES	8	1	- 8	
Medusa	132	1	- 132	
IFU	15	20	15	315
<b>ARGUS</b>	<b>1</b>	<b>14x22 (-8)</b>	<b>15</b>	<b>315</b>

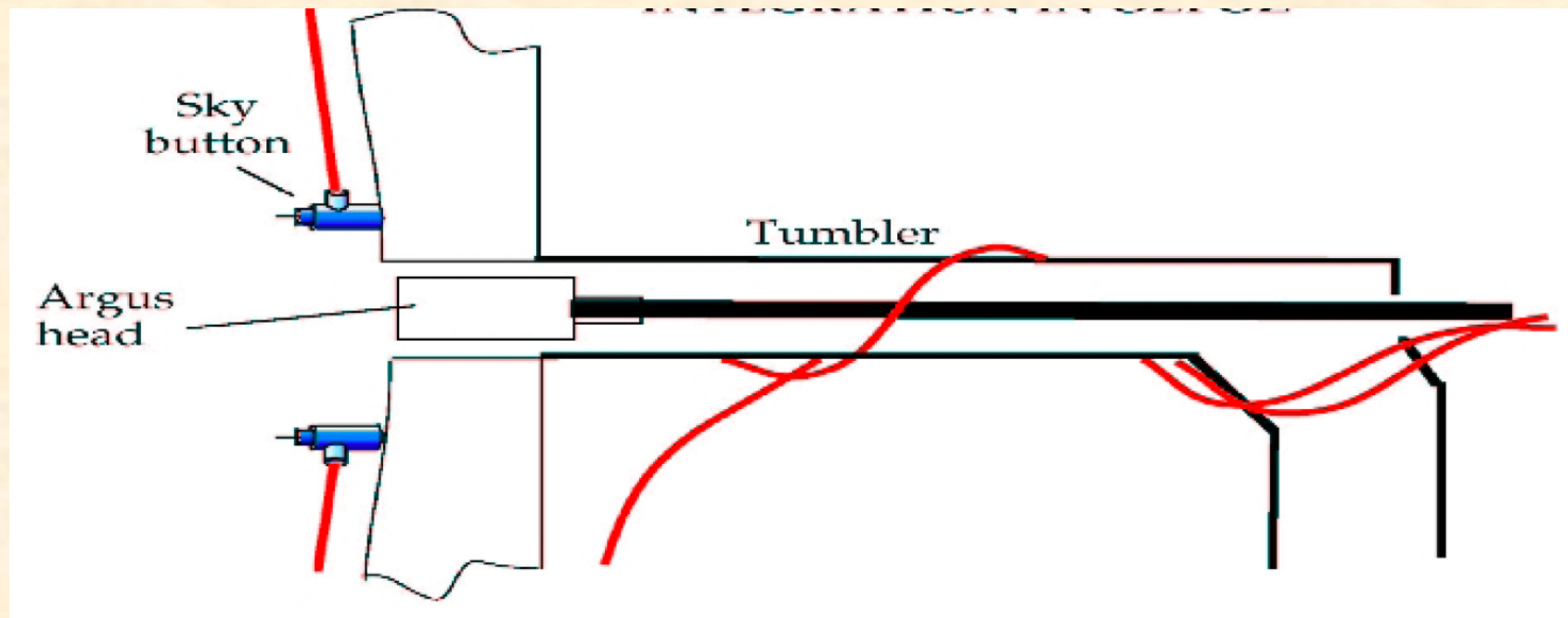

# Flames - ARGUS

Mode	Number of Buttons	Fibers per Buttons	Sky Buttons	Total fibers
UVES	8	1	8	
Medusa	132	1	132	
IFU	15	20	15	315
<b>ARGUS</b>	<b>1</b>	<b>14x22 (-8)</b>	<b>15</b>	<b>315</b>

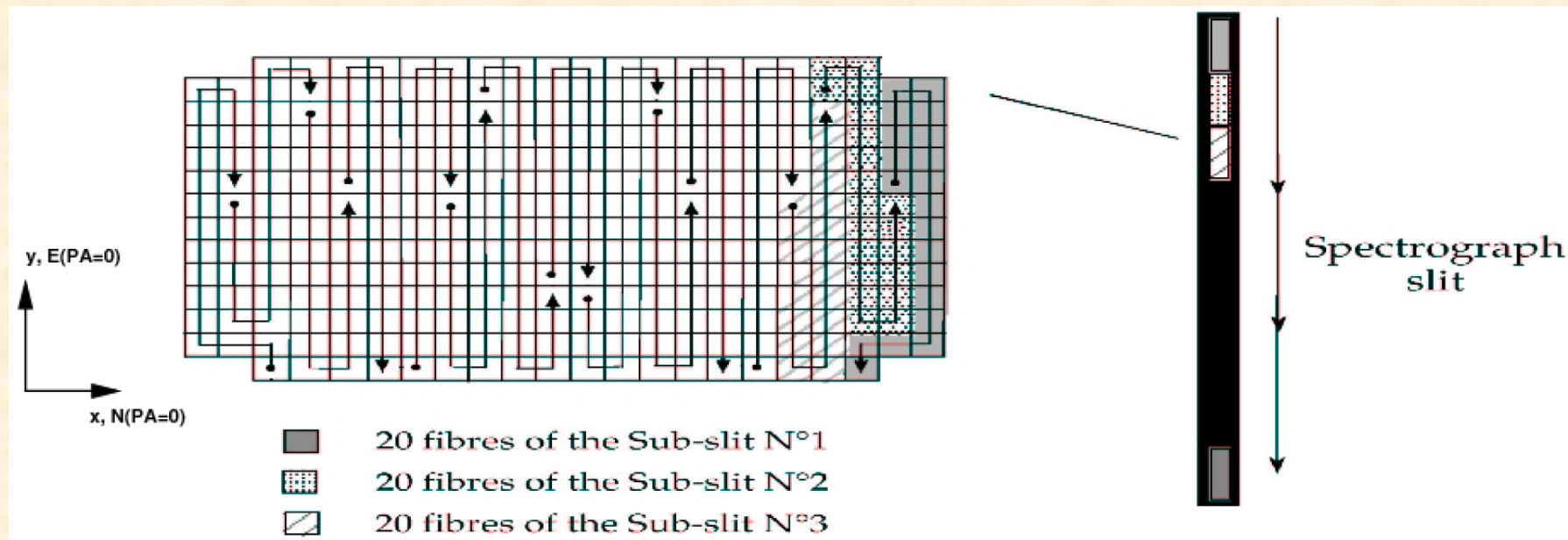



# Flames - ARGUS

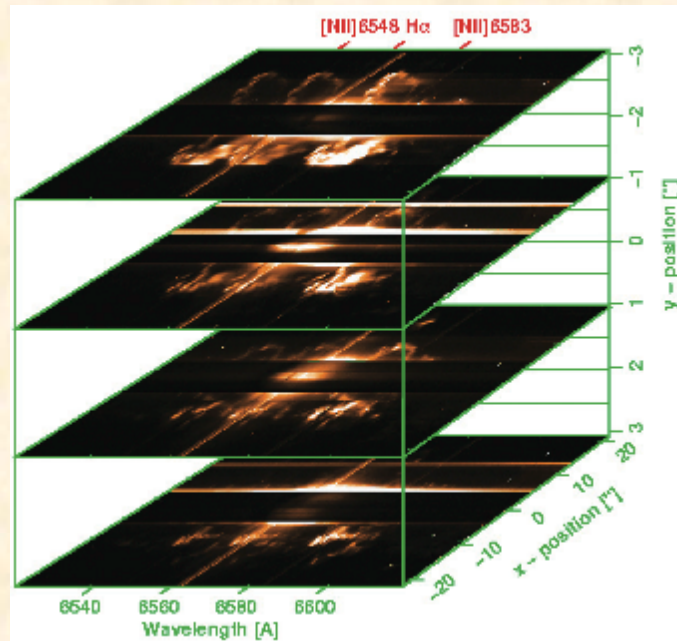
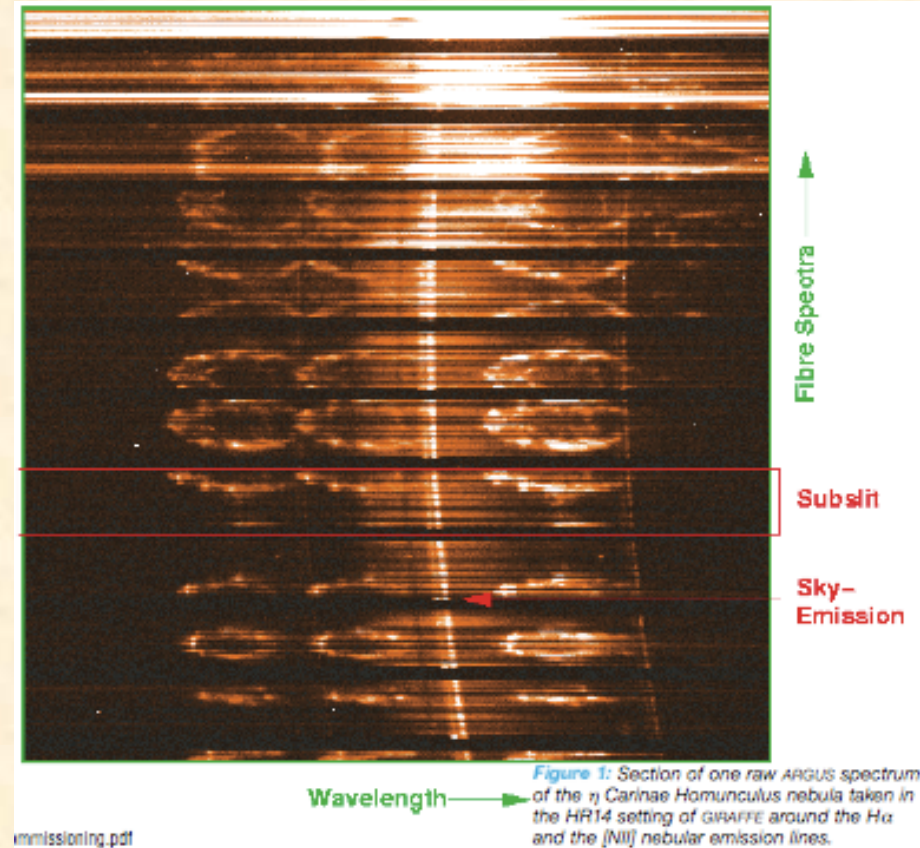
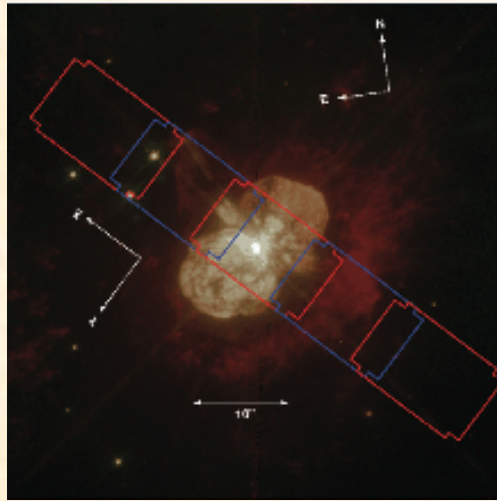

# Flames - Summary

Spectro.	Mode	N. Objects	Aperture ["]	R	Cover.
UVES	RED	8 (with sky)	1.0	47000	200
UVES7	RED	7 (with sky) +1 Simul. Calib.	1.0	47000	200
GIRAF HR	MEDUSA	131 <sup>a</sup> (with sky)	1.2	19000 <sup>†</sup>	$\lambda/22 - \lambda/12$
GIRAF LR	MEDUSA	131 <sup>a</sup> (with sky)	1.2	7000 <sup>†</sup>	$\lambda/9.5$
GIRAF HR	IFU	15 (+15 sky)	2×3	30000 <sup>†</sup>	$\lambda/22 - \lambda/12$
GIRAF LR	IFU	15 (+15 sky)	2×3	11000 <sup>†</sup>	$\lambda/9.5$
GIRAF HR	ARGUS	1	11.5×7.3 or 6.6×4.2	30000 <sup>†</sup>	$\lambda/22 - \lambda/12$
GIRAF LR	ARGUS	1	11.5×7.3 or 6.6×4.2	11000 <sup>†</sup>	$\lambda/9.5$

# Flames - Summary

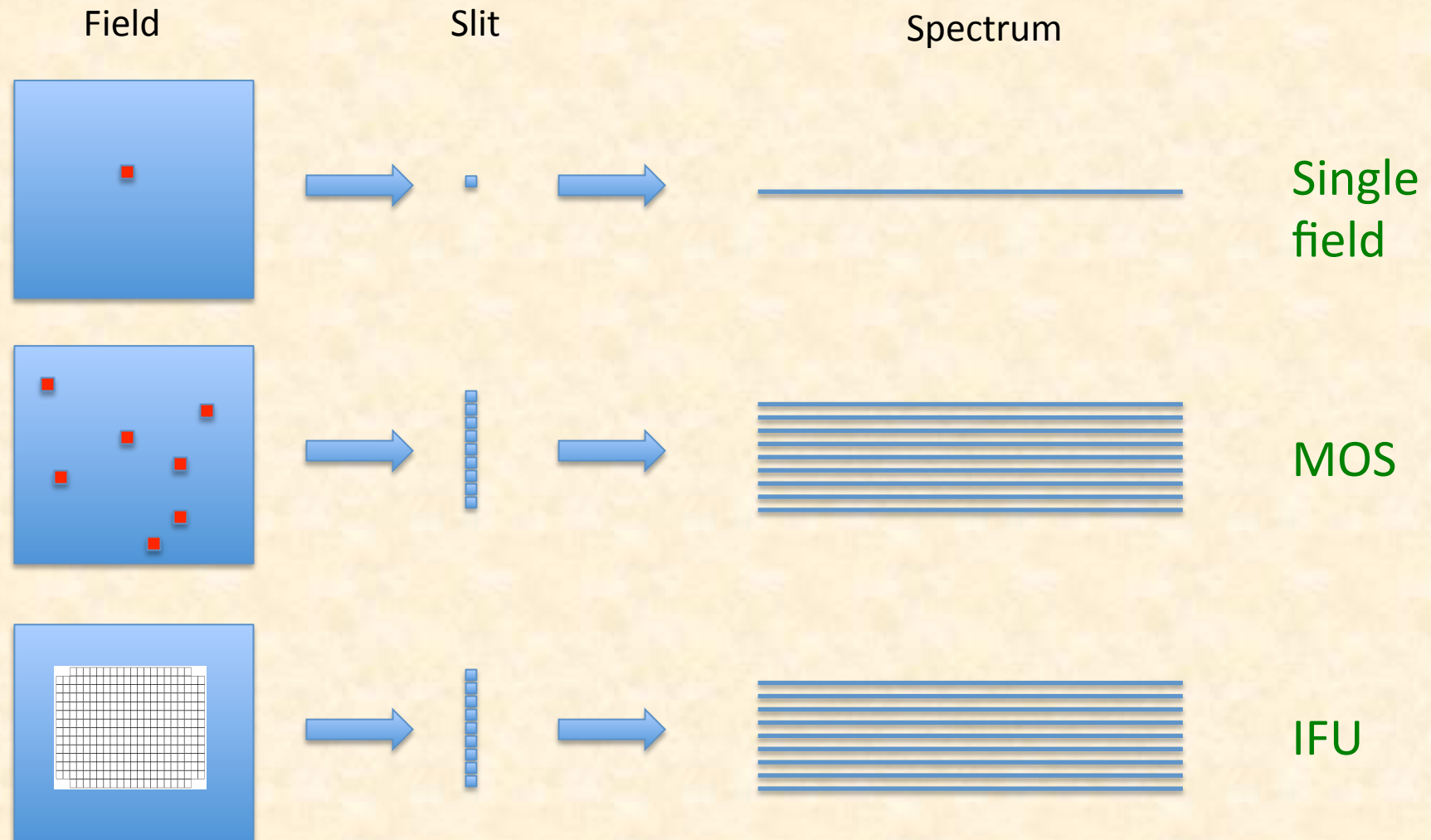

# VIMOS@VLT

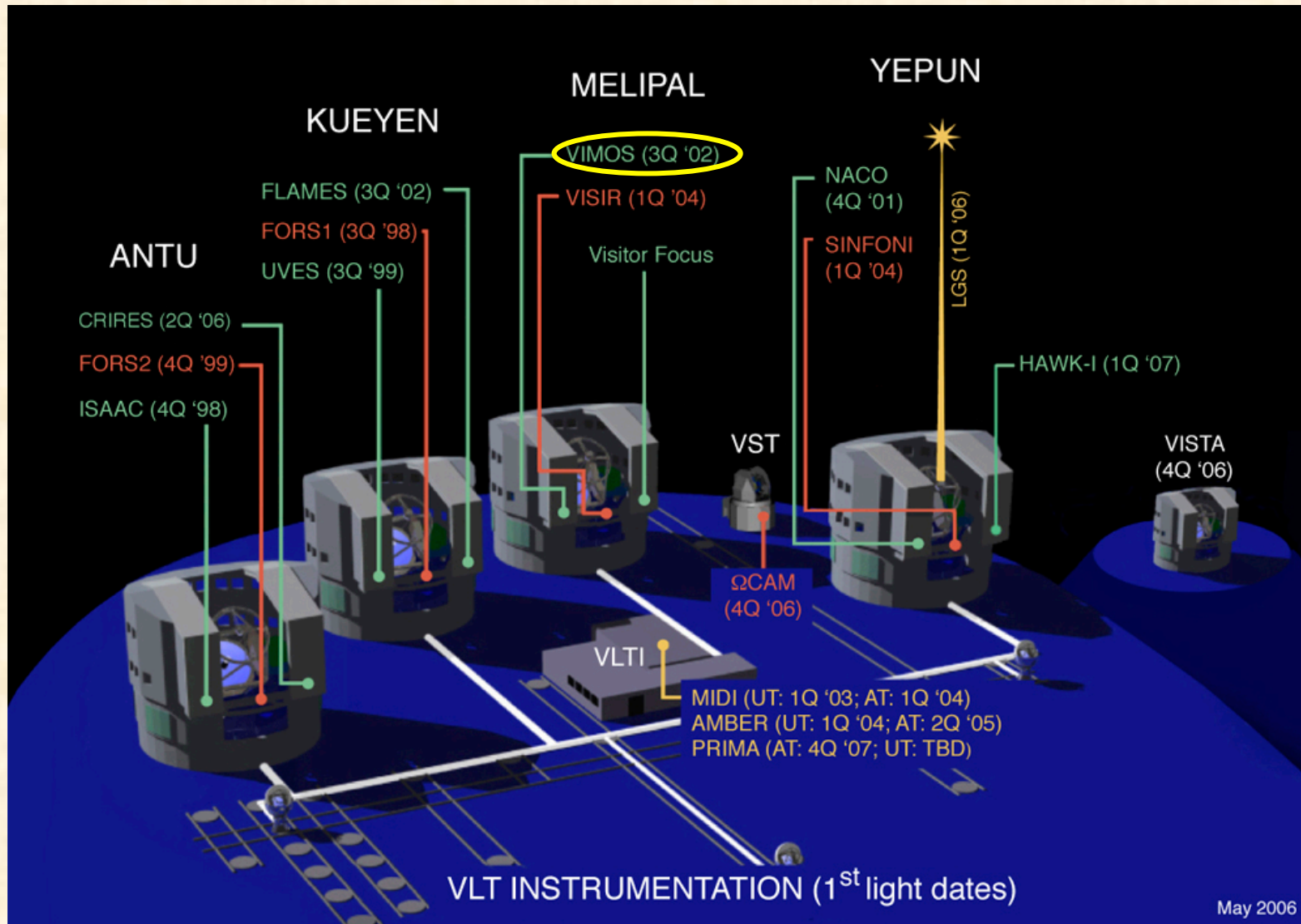

# VIMOS@VLT



# VIMOS - Modes

IMG: Imaging is possible in UBVRIz filters in a 4 x 7' x 8' field of view.

MOS: Multi-object spectroscopy is carried out using masks (one per quadrant) prepared in Paranal using a laser cutting Mask Manufacturing Unit. Depending on the grism used, the spectral resolution varies from 200 to 2500, and the observable range is from 360 to 1000 nm. The maximum number of slits per mask (quadrant) varies from ~40 at R=2500 to ~150-200 at R=200, for a field of view of 4 x 7' x 8'. (like FORS)

IFU: VIMOS is also equipped with an integral field unit made of 6400 fibers. The scale on the sky can be changed from 0.67" per fiber to 0.33" per fiber and the integral field unit can cover up 13"x 13" up to 54"x54" on sky depending on spectral resolution and spatial magnification. Spectral resolution and coverage are similar to MOS. (like Flames-Argus)

# VIMOS instrument

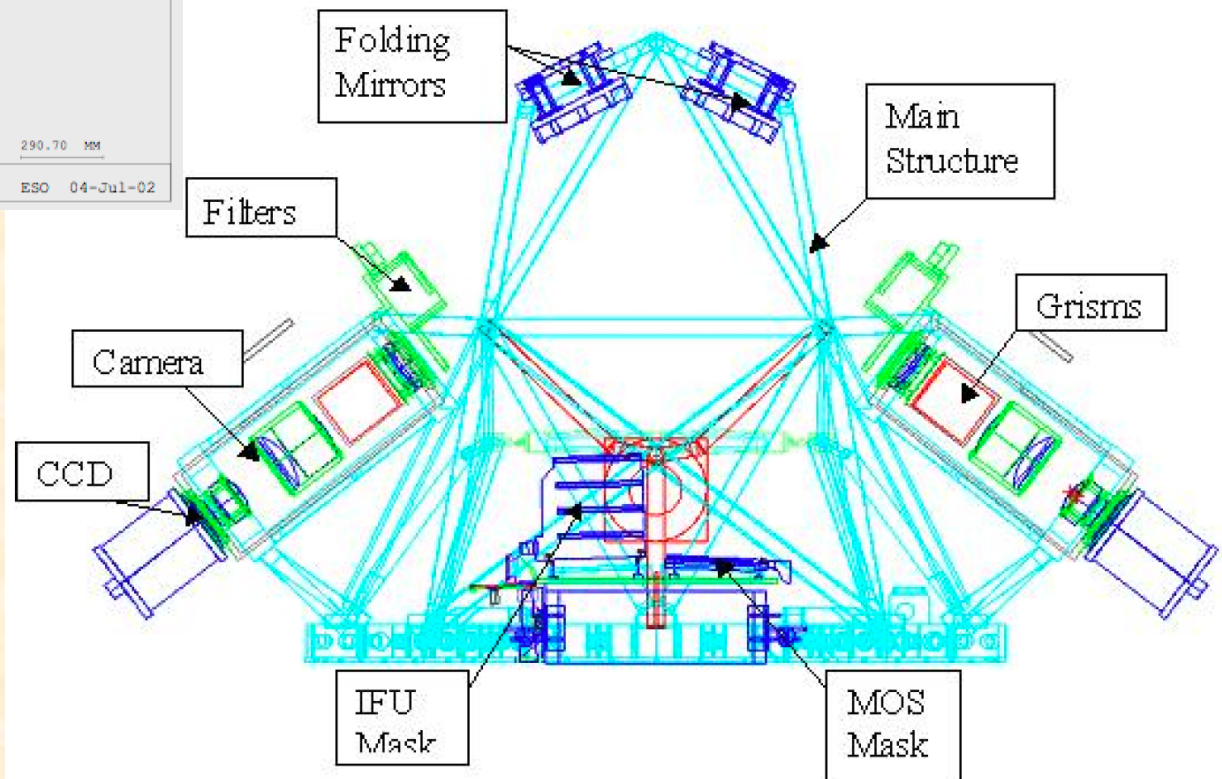
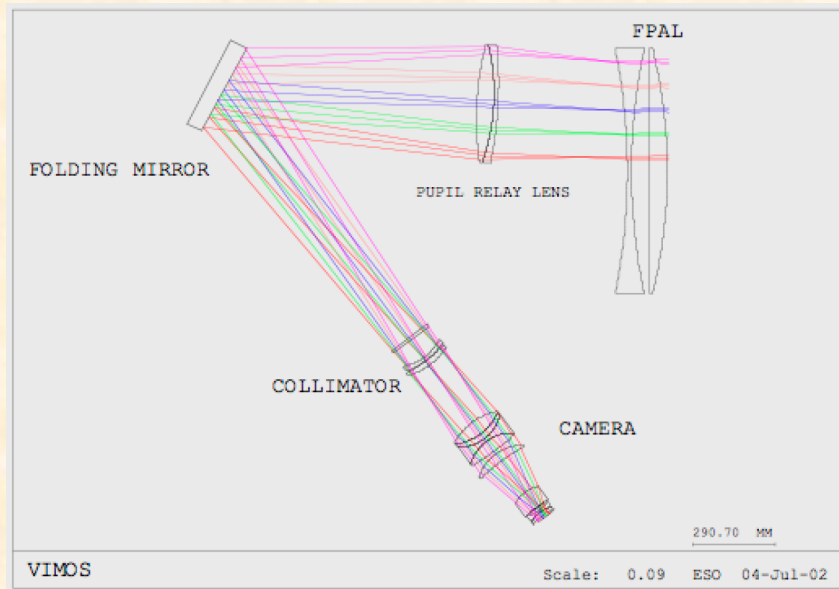

# VIMOS instrument

Table 2.1: VIMOS opto-mechanical characteristics

Instrument Location	Nasmyth B VLT-UT3 (Melipal)
Opto-mechanical layout	4 beams, each a complete focal-reducer, F/1.88 output
Wavelength coverage	0.37 to 1 microns
Detectors	$4 \times 2048 \times 4096$ , $15 \mu\text{m}/\text{pixel}$
Spectral Resolution	$R = 180$ to $2500$ (1 arcsec slit)
Filters	10 per channel, $U'BVRIZ$ , OS-red, OS-blue, GG435, GG475, 170mm diameter
Grisms	6 per channel, LR red, LR blue, MR, HR blue, HR orange, HR red <sup>[1]</sup>
Flexures	Passive compensation, motion of $\pm 2$ pixels over $360^\circ$ rotation
Masks	10 masks simultaneously loaded in instrument (practical) maximum (per channel) <sup>[2]</sup> . Slits of any position and shape, width $> 0.6''$ , length $< 30''$ .
Multiplex	840 simultaneous slits, $10''$ long at $R = 200$ 210 simultaneous slits, $10''$ long at $R = 2000-2500$
Integral Field Unit	$54'' \times 54''$ field, 6400 fibers with $0.67''$ sampling $27'' \times 27''$ field, 6400 fibers with $0.33''$ sampling



# VIMOS MOS

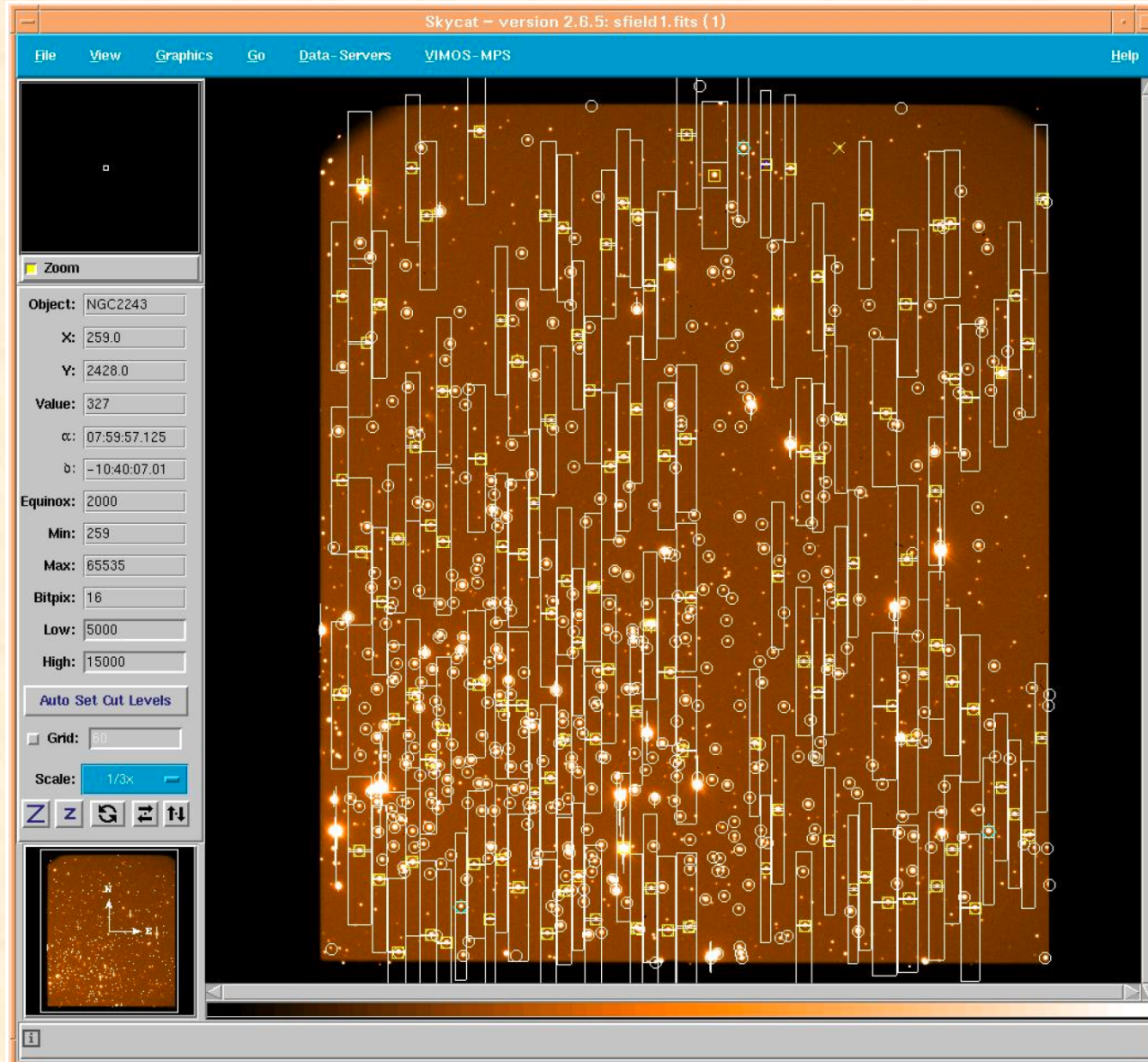

# VIMOS IFU

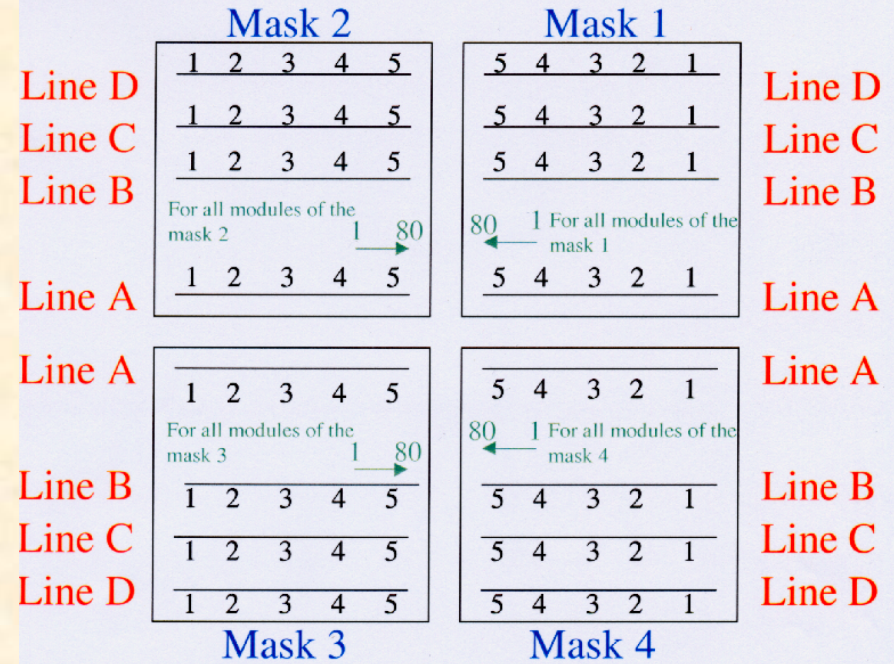
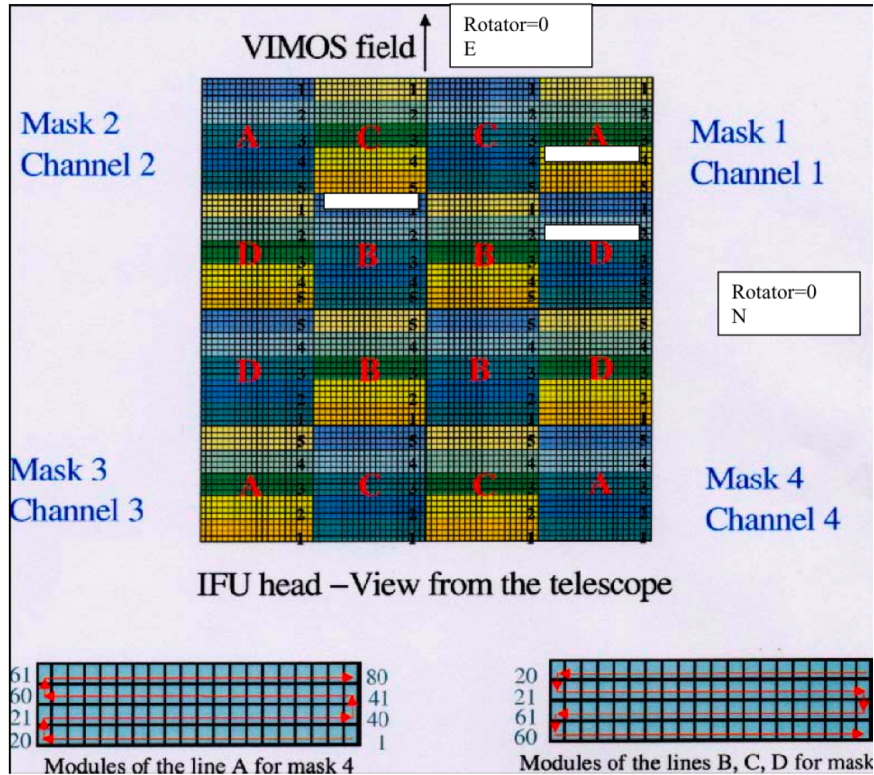

View from the telescope

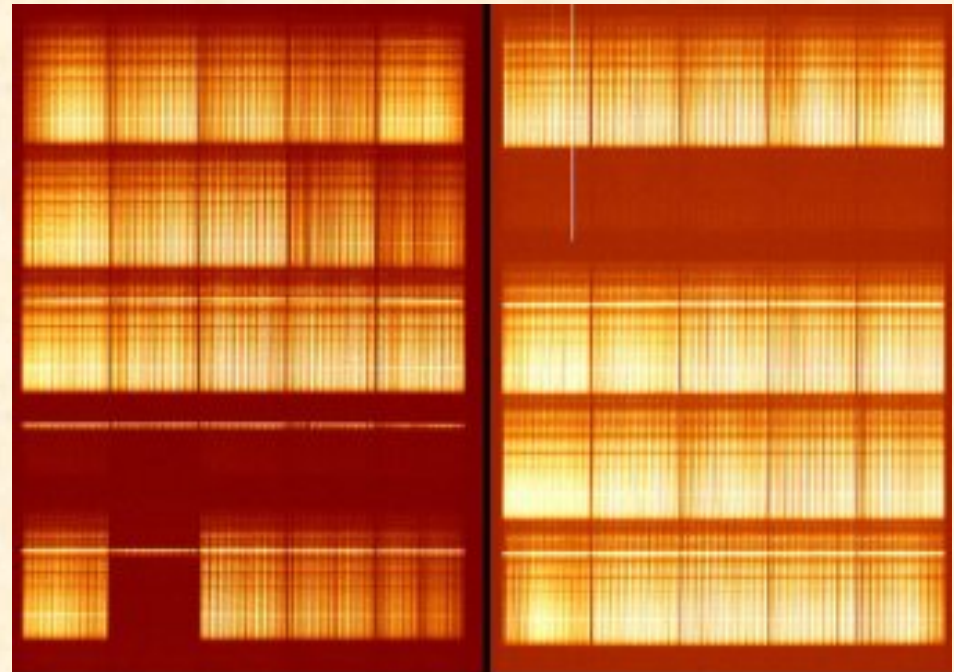

# Sinfoni@VLT

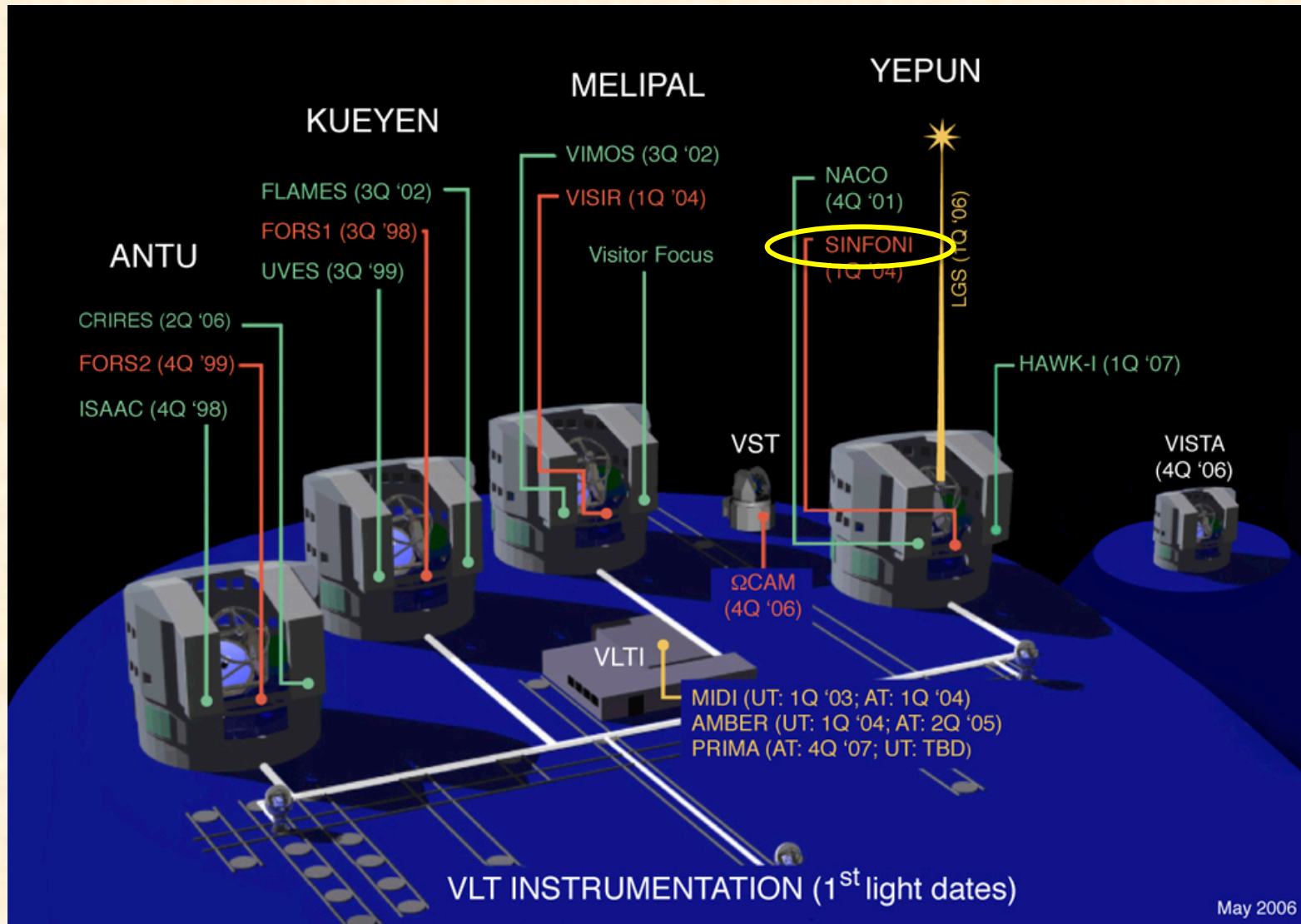

# Sinfoni@VLT



Infrared spectrograph  
(SPIFFI)

Dispersion grating

Cryogenic instrument  
Adaptive optics  
(SINFONI)

-> 'Small' instrument

-> enhance faint objects  
wrt to IR background

IFU module

# Sinfoni@VLT

SINFONI is a near-infrared (1.1 - 2.45  $\mu\text{m}$ ) integral field spectrograph fed by an adaptive optics module. The spectrograph operates with 4 gratings (J, H, K, H+K) providing a spectral resolution around 2000, 3000, 4000 in J, H, K, respectively, and 1500 in H+K - each wavelength band fitting fully on the 2048 pixels of the Hawaii 2RG (2kx2k) detector in the dispersion direction. The SINFONI field of view on the sky is sliced into 32 slices. The pre-slit optics allows to chose the width of the slices. The choices are 250mas, 100mas and 25mas, leading to field of views on the sky of 8"x8", 3"x3", or 0.8"x0.8" respectively. Each one of the 32 slitlets is imaged onto 64 pixels of the detector. Thus one obtains 32x64 spectra of the imaged region on the sky.

# Sinfoni@VLT

**Field of view** The pre-optics of the spectrograph allow to chose between 3 plate-scales, providing fields of  $8'' \times 8''$  ,  $3'' \times 3''$  ,  $0.8'' \times 0.8''$  . Each of these fields is then cut into 32 slices, and each slice is projected onto 64 detector pixels. Thus, the spatial resolution elements (spaxels) on the sky are rectangular.

Field of view	Spaxel size on the sky
$8'' \times 8''$	125mas $\times$ 250mas
$3'' \times 3''$	50mas $\times$ 100mas
$0.8'' \times 0.8''$	12.5mas $\times$ 25mas

**Wavelength bands** Four gratings are installed on a turret in the spectrograph: J,H,K, H+K. The dispersions are chosen such that the full wavelength range is covered by the detector in each case.

Band	Dispersion	FWHM of line	Resolution	$\lambda$ range
J	0.15nm/pix	$\sim$ 4pix	$\sim$ 2000	1.10 – 1.40 $\mu$ m
H	0.20nm/pix	$\sim$ 3pix	$\sim$ 3000	1.45 – 1.85 $\mu$ m
K	0.25nm/pix	$\sim$ 2pix	$\sim$ 4000	1.95 – 2.45 $\mu$ m
H+K	0.50nm/pix	$\sim$ 2pix	$\sim$ 1500	1.45 – 2.45 $\mu$ m

# Spiffi's IFU

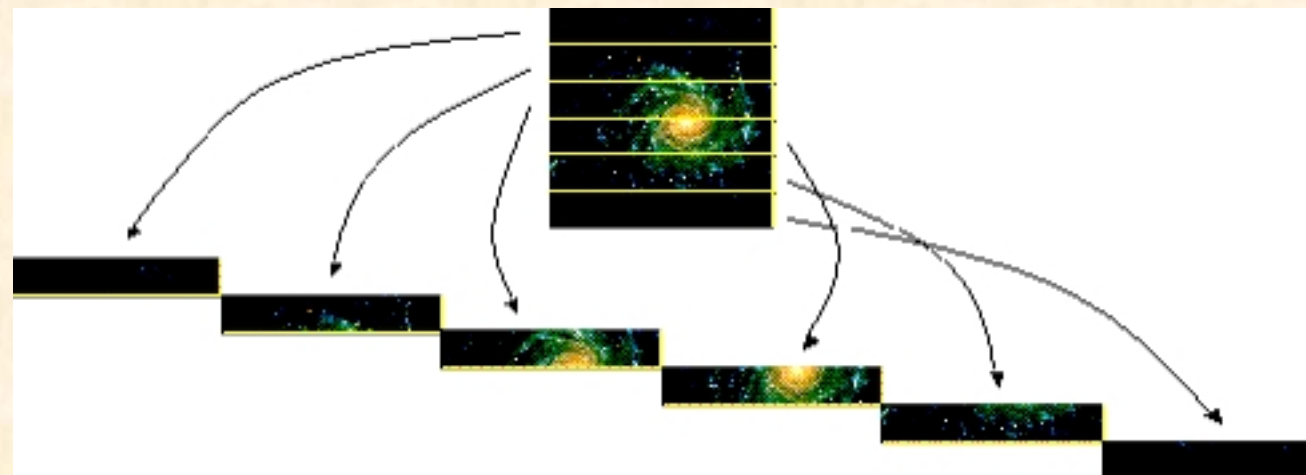
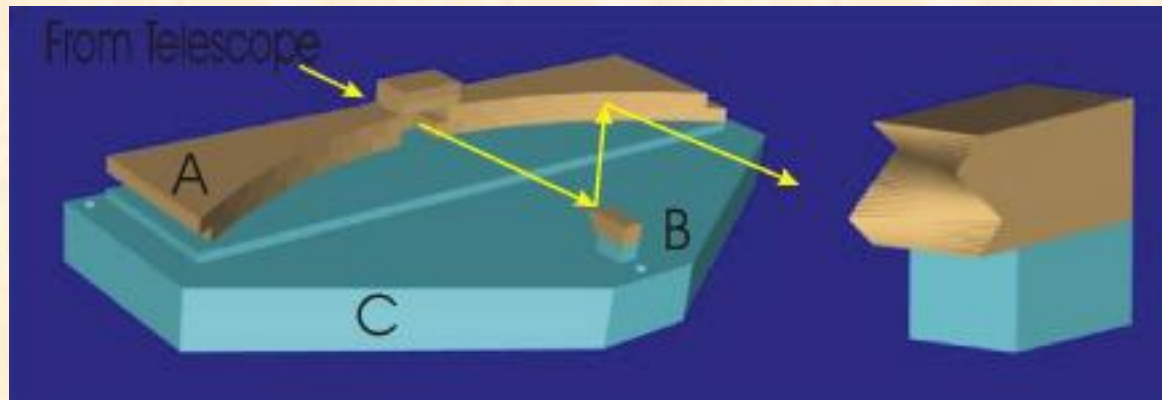

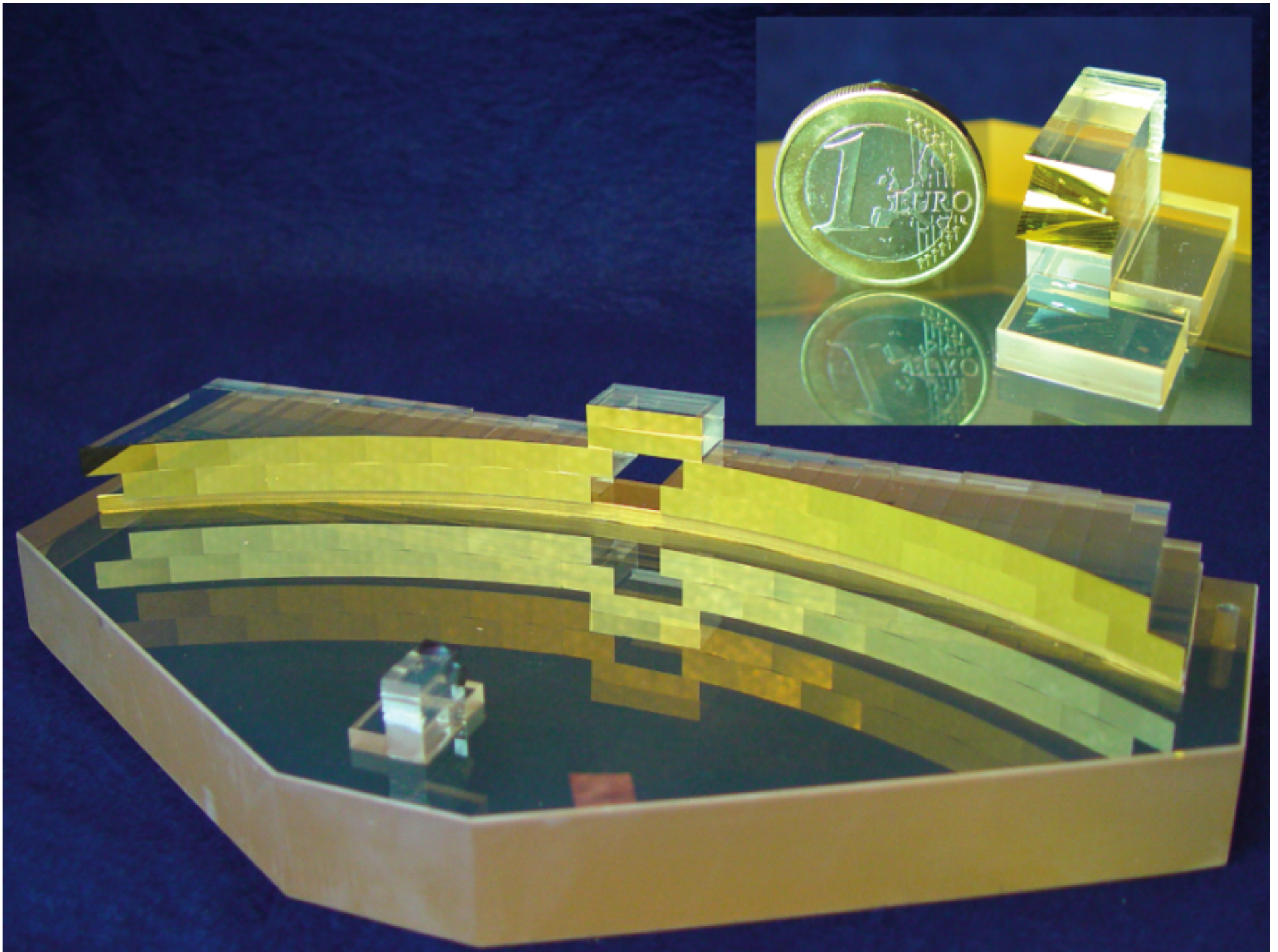



Two dimensional original on-sky image



Optical slicing of the on-sky image

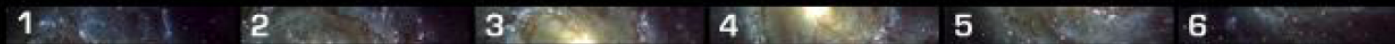

Spectral dispersion of the sliced image



Computer reconstruction of the 3D data cube

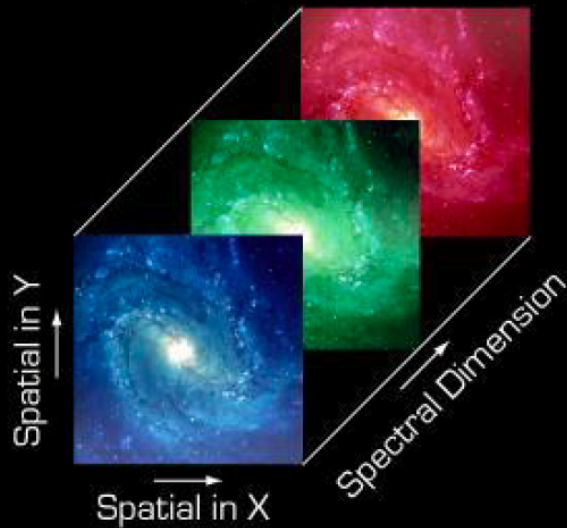

Spectrum of each 2D pixel

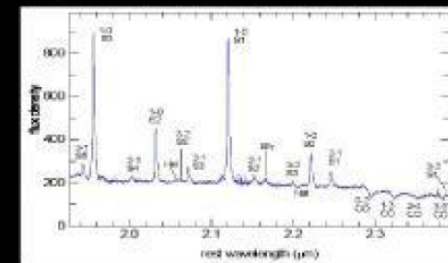

Computer reconstructed image



# Future VLT spectrographs

## X-shooter:

- Single-field
- Medium resolution
- Extreme wavelength range in one shot from 300 nm to 2.5  $\mu\text{m}$  in 3 arms
- IFU unit
- Already commissioned

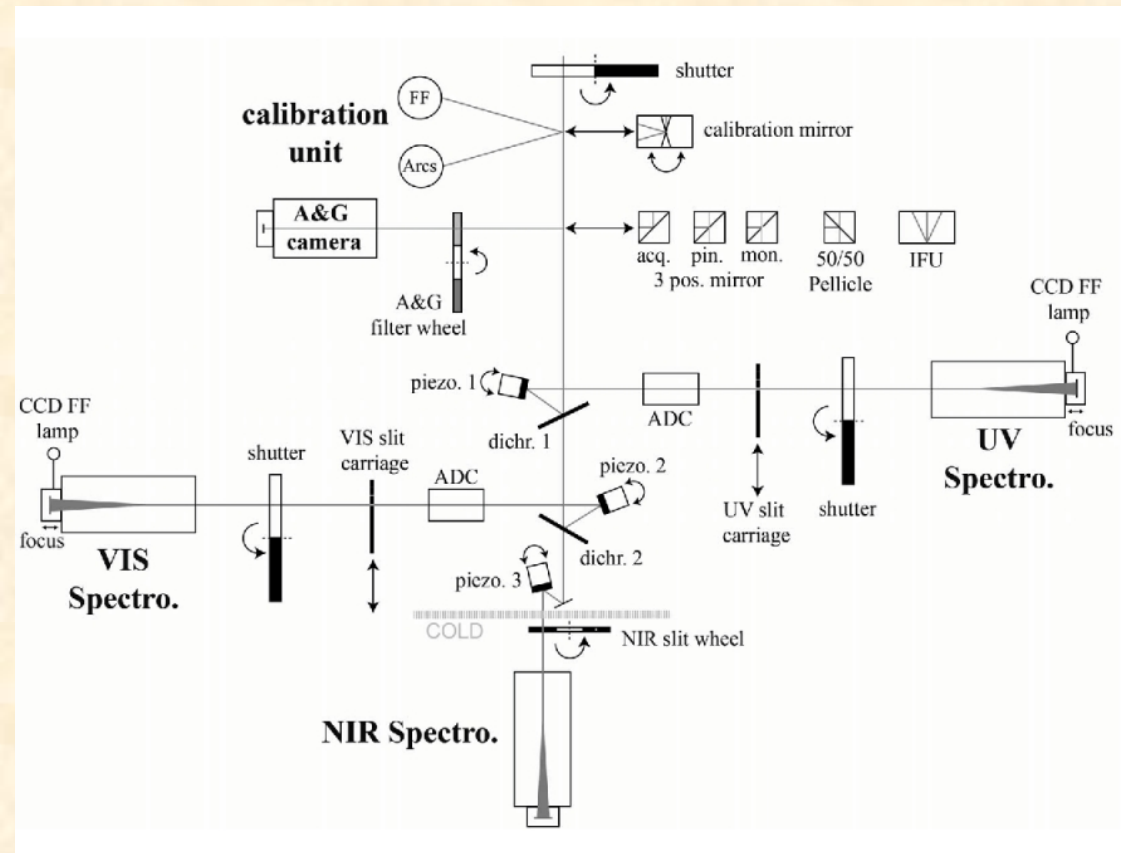

# Future VLT spectrographs

X-shooter

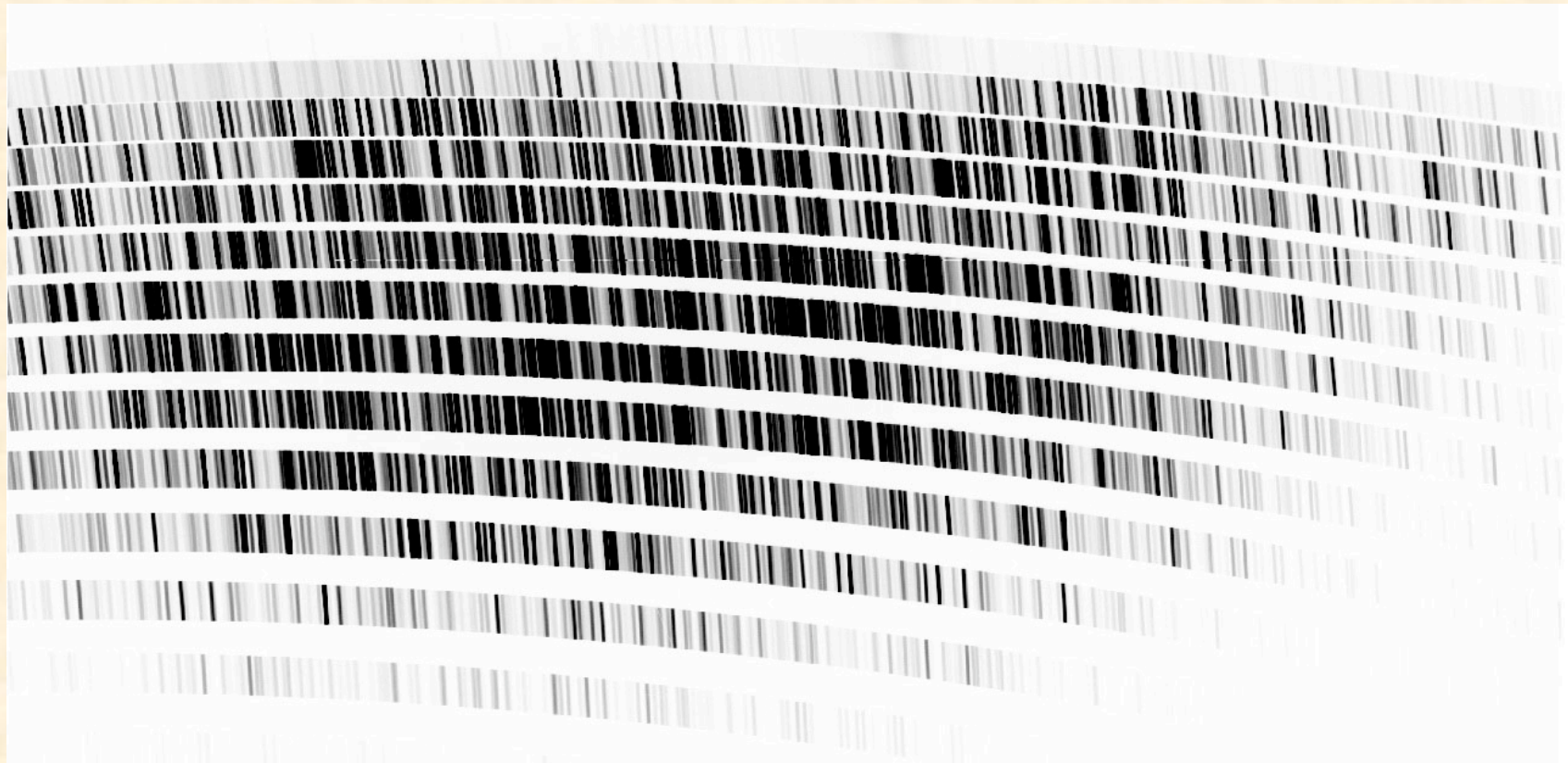

# Future VLT spectrographs

## MUSE:

- AO
- IFU with 1' x 1' (0,2" sampling) or 7.5" x 7.5" (0,025" sampling)
- Array of 24 fields organized in 24 spectrographs
- Resolution 2000 - 4000 @ NIR
- Available in 2011

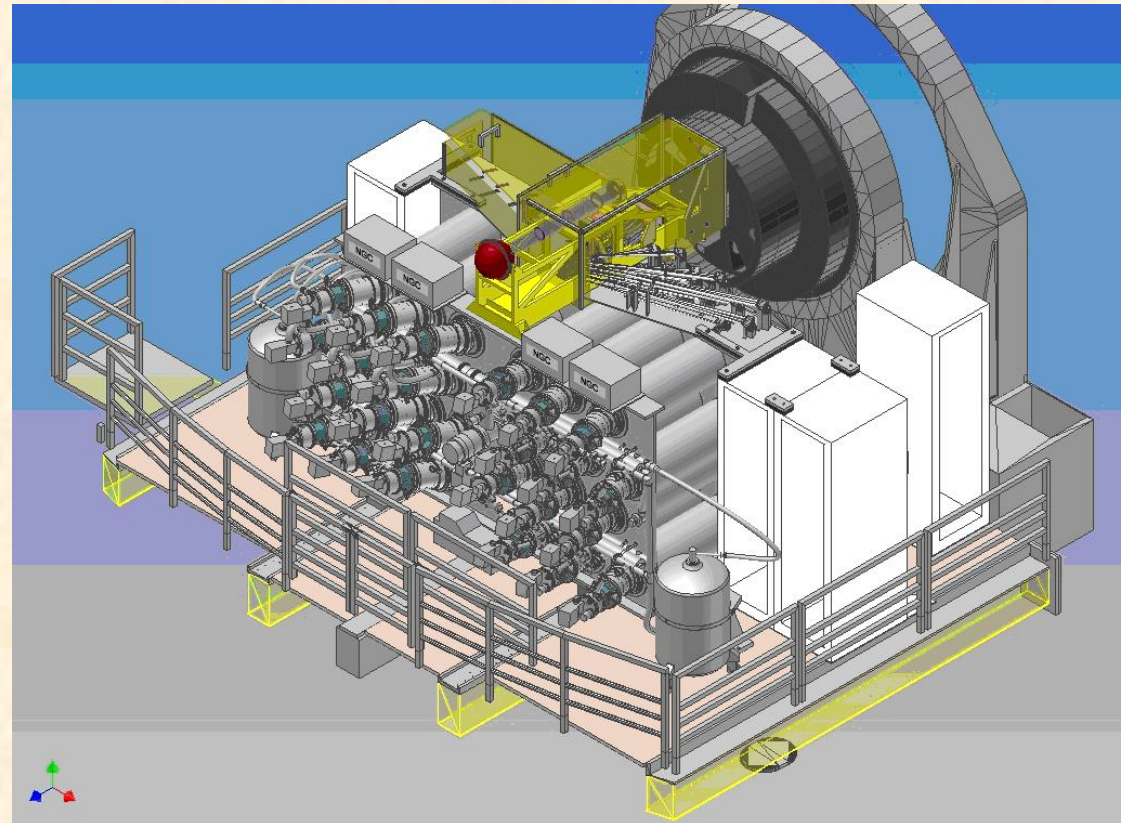

# Future VLT instruments

## Science objectives of MUSE:

Formation of galaxies: high redshift Lyman alpha emitters, fluorescent emission and the cosmic web, reionisation, feedback processes and galaxy formation, ultra-deep surveys using strong gravitational lensing, resolved spectroscopy at intermediate redshifts, Sunyaev-Zeldovich effect late forming population III objects

Nearby galaxies: supermassive black holes in nearby galaxies, kinematics and stellar populations, interacting galaxies, star formation in nearby galaxies

Stars and resolved stellar populations: early stages of stellar evolution, massive spectroscopy of stellar fields: the Milky Way and the Magellanic Clouds, the Local Group and beyond

Solar system: Galilean satellites, Titan surface, heterogeneities of the small bodies, temporal changes in the gas giant planets

# Future VLT spectrographs

## ESPRESSO:

- No AO
- Single field, fiber-fed echelle spectrograph
- High spectral resolution ( $R = 140'000$ )
- Extreme stability for highest RV precision
- Uses up to 4 UTs
- (first 16-m-equivalent
- telescope)
- Available in 2014

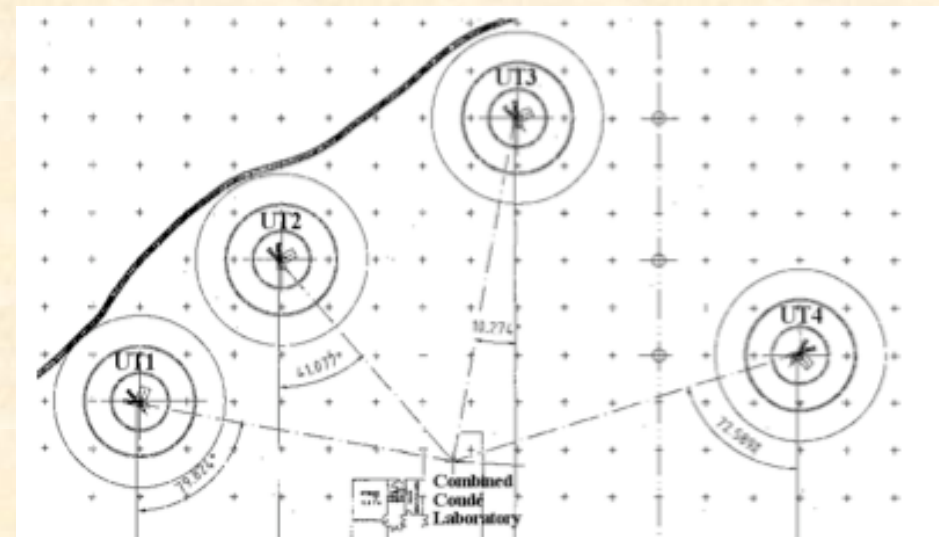

# Future VLT spectrographs

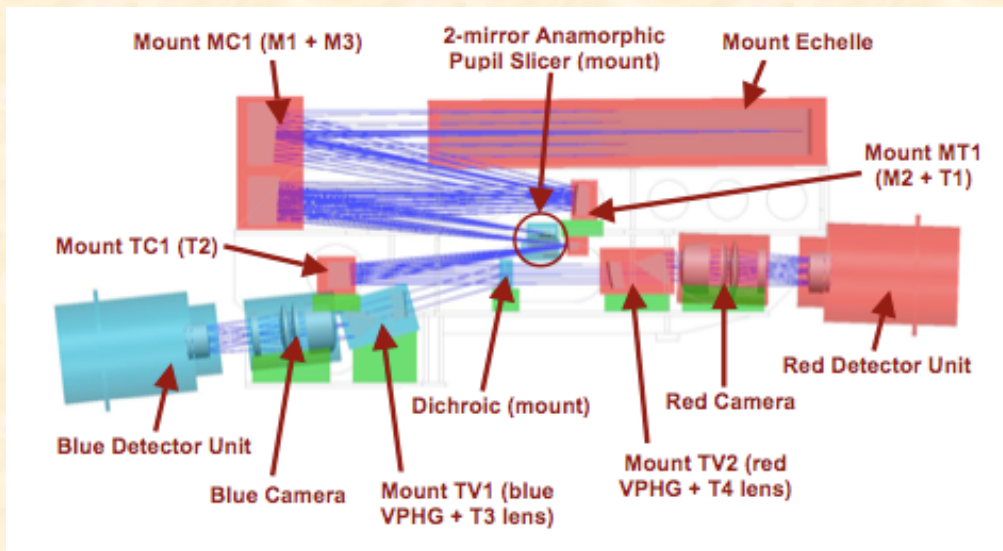

r deck)

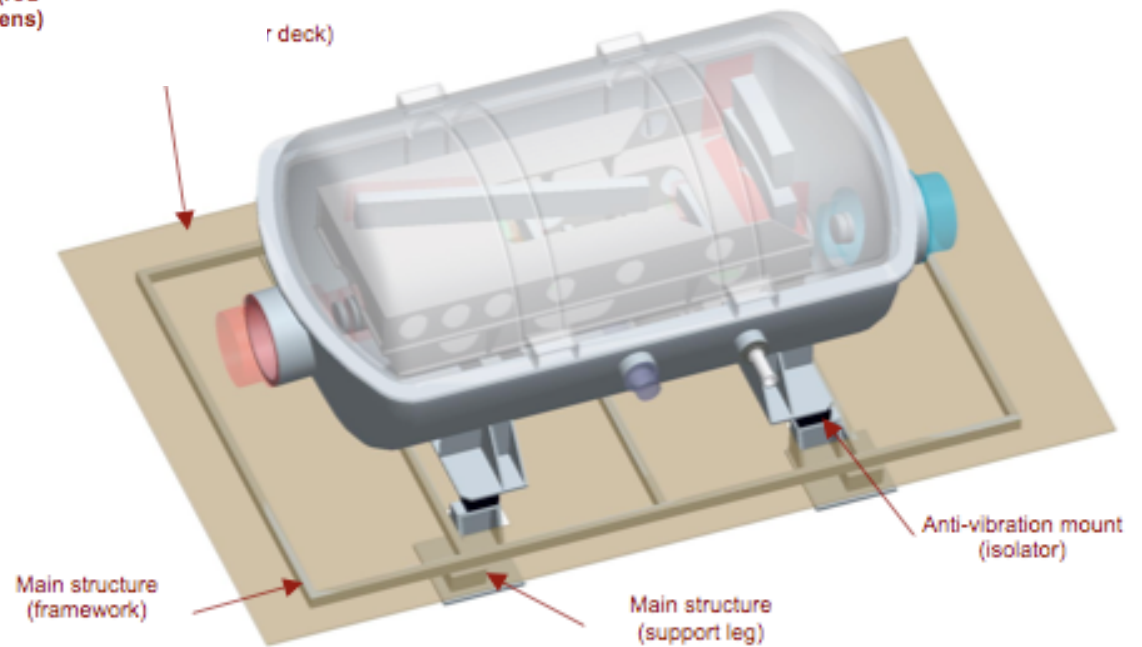

# Future VLT spectrographs

## ESPRESSO Science:

- Low-mass and rocky extra-solar planets
- Planets around late-type stars
- Variability of physical constants
- Abundances in near-by galaxies
- Etc.



# Challenges for ELT spectrographs

- Huge telescope -> huge instrumentations (conservation of étendu)
- Or, massive adaptive optics (very complex and demanding with increasing telescope size, difficulty increases with  $D$  and with  $\sim 1/\lambda$ )
- Location of the instruments (trade-off between stability and efficiency)
- Costs