

Strictly confidential. All rights reserved. Reproduction and processing of data in electronic systems or in any form whatever is not permitted without written authority of FISBA OPTIK AG.

Streng vertraulich. Alle Rechte vorbehalten. Die Vervielfältigung und die Verarbeitung mit elektronischen Systemen ist ohne schriftliche Genehmigung der FISBA OPTIK AG nicht gestattet.

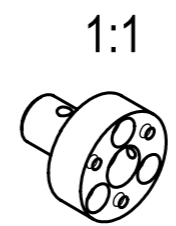
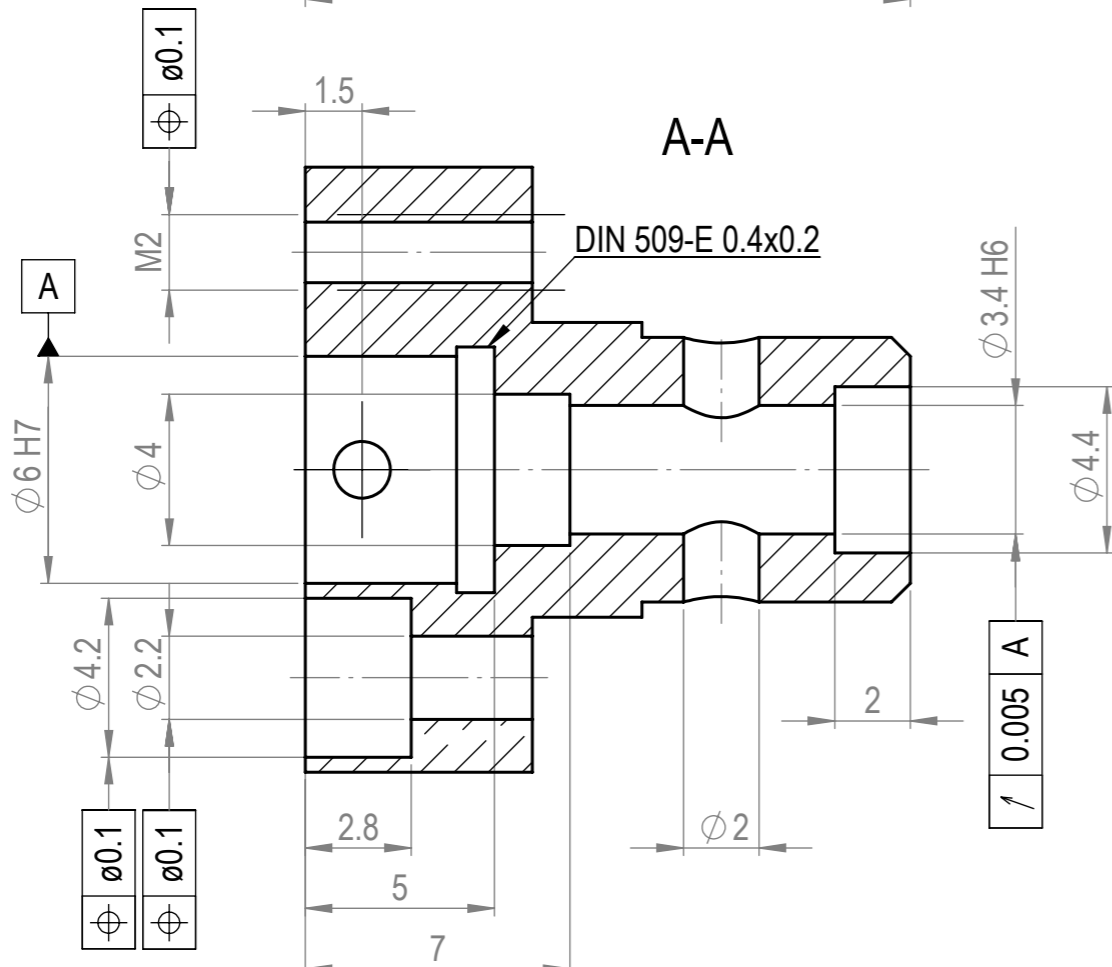
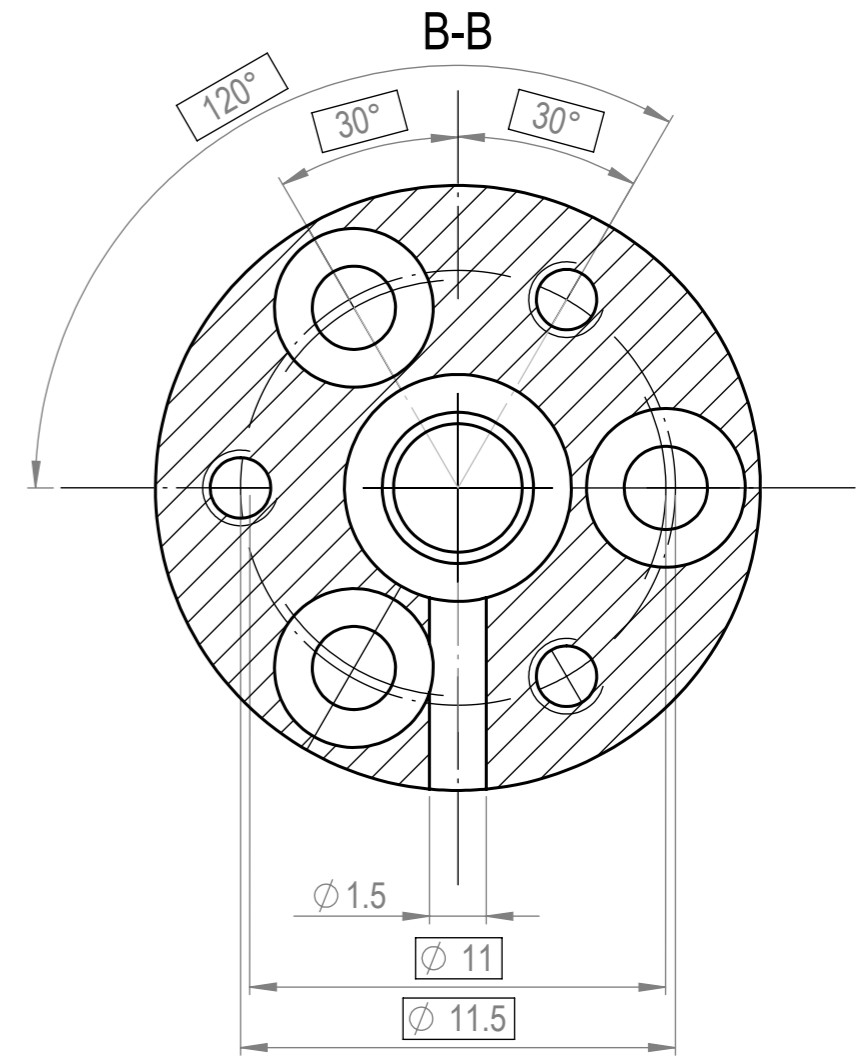
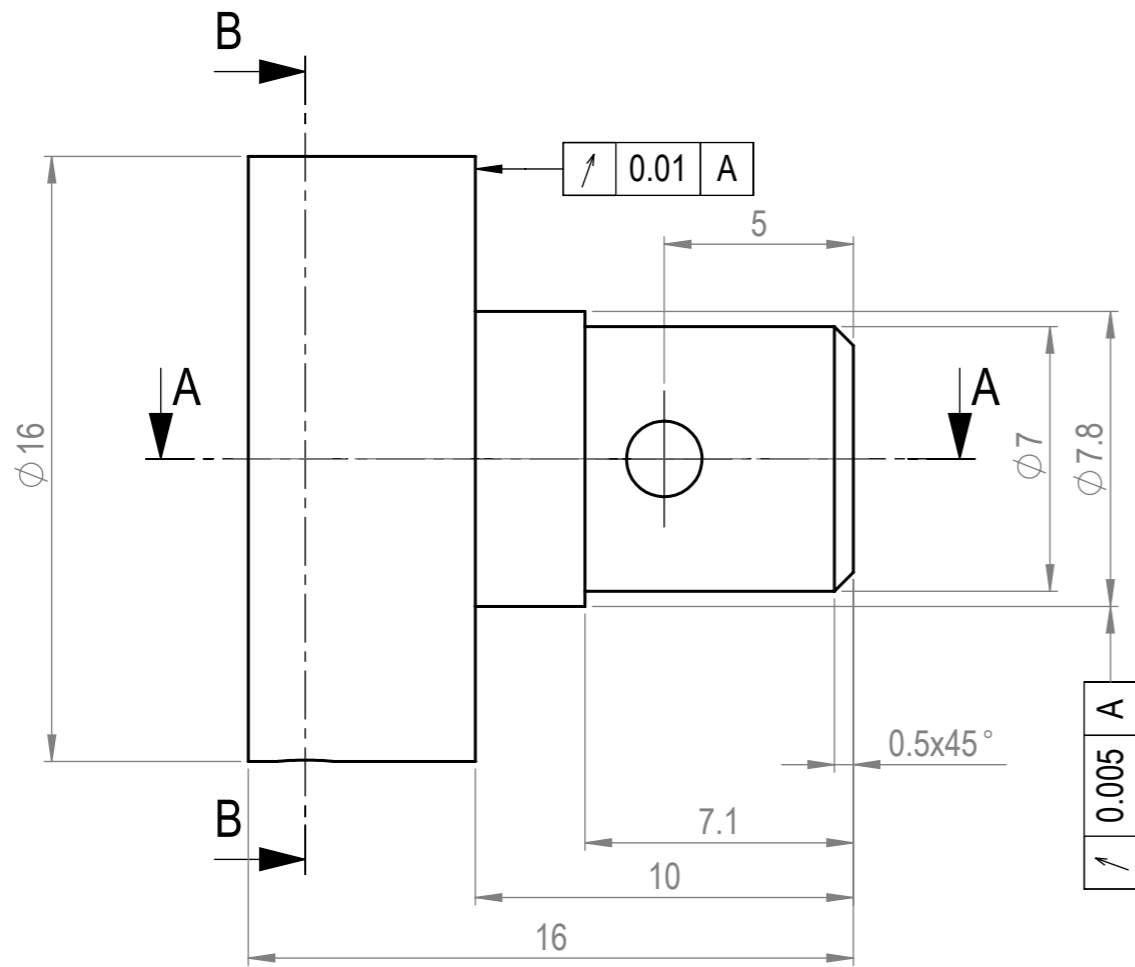

N7

Dimension nach Oberflächenbehandlung <i>Dimensions after surface treatment</i>			Oberfläche <i>Surface</i>	chemisch schwarz	Material <i>Material</i>	2.0401 (CuZn39Pb3)	Kanten gebrochen 0.1...0.2x45° <i>Edges chamfered 0.1...0.2x45°</i>
Erstellt <i>Prepared</i>	30.11.2009	brt	Gewicht <i>Weight</i>	8.4 g	Benennung / <i>Description</i>		Blatt / Anz. <i>Sheet / no. of</i>
Freigegeben <i>Approved</i>		-	Status <i>Status</i>	in Bearbeitung	Fassung		1 / 1
Geändert <i>Modified</i>		-	Änderungs-Nr. <i>Revision no.</i>				Format <i>Format</i>
Allgemeintoleranzen Mechanik <i>General mechanical tolerances</i>			Massstab / <i>Scale</i> 5:1		Zeichnungs-Nr. / <i>Drawing no.</i>		Version <i>Version</i>
Längenmasse / <i>Linear dimensions</i>			www.fisba.ch		00.234.03-060		-+
Mass / <i>Dimension</i>	0 ... 20	> 20 ... 50	> 50 ... 120	> 120			
Tol. / <i>Tol.</i>	± 0.1	± 0.15	± 0.2	± 0.3			