

Strictly confidential. All rights reserved. Reproduction and processing of data in electronic systems or in any form whatever is not permitted without written authority of FISBA OPTIK AG.

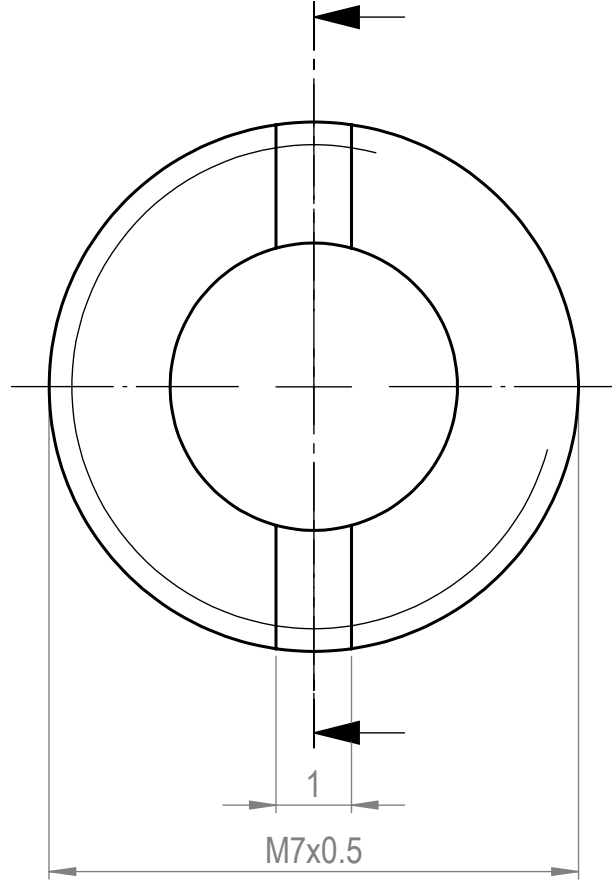

1:1

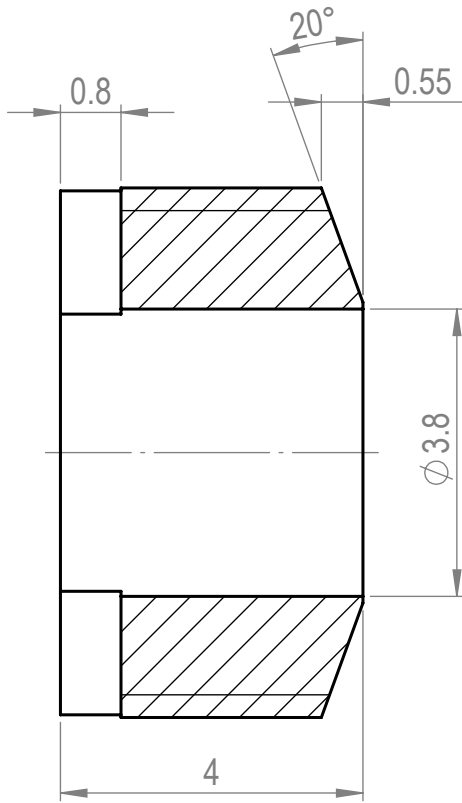

N7

Streng vertraulich. Alle Rechte vorbehalten. Die Vervielfältigung und die Verarbeitung mit elektronischen Systemen ist ohne schriftliche Genehmigung der FISBA OPTIK AG nicht gestattet.

Dimension nach Oberflächenbehandlung <i>Dimensions after surface treatment</i>				Oberfläche <i>Surface</i>	chemisch schwarz	Material <i>Material</i>	1.4305 (X8CrNiS18-9)	Kanten gebrochen 0.1...0.2x45° <i>Edges chamfered 0.1...0.2x45°</i>
Erstellt <i>Prepared</i>	30.11.2009	brt	Gewicht <i>Weight</i>	0.8 g	Benennung / Description Si-Ring			Blatt / Anz. <i>Sheet / no. of</i>
Freigegeben <i>Approved</i>		-	Status <i>Status</i>	in Bearbeitung				1 / 1
Geändert <i>Modified</i>		-	Änderungs-Nr. <i>Revision no.</i>					Format <i>Format</i>
Allgemeintoleranzen Mechanik <i>General mechanical tolerances</i>					Massstab / Scale 10:1	Zeichnungs-Nr. / Drawing no.		Version <i>Version</i>
Längenmasse / Linear dimensions				 www.fisba.ch		00.234.03-100		-+
Mass / Dimension	0 ... 20	> 20 ... 50	> 50 ... 120					
Tol. / Tol.	± 0.1	± 0.15	± 0.2	± 0.3				