

## SECTION L

### FUEL SYSTEM

<u>Section</u>	<u>Description</u>	<u>Page No.</u>
L.1	General Description	3
L.2	Fuel System	3
L.3	Fuel Tank	4
L.4	Fuel Tank Sender Unit	8
L.5	Fuel Gauge	8
L.6	Fuel Pump	9
L.7	Weber Carburetters: Description	12
L.8	Weber Carburetters: Removing	18
L.9	Weber Carburetters: Adjusting	21
L.10	Weber Carburetters: Cleaning	22
L.11	Weber Carburetters: Overhaul	23
L.12	Zenith Stromberg Carburetters: Description	30
L.13	Zenith Stromberg Carburetters: Removing	37
L.14	Zenith Stromberg Carburetters: Adjusting	37
L.15	Zenith Stromberg Carburetters: Cleaning	39
L.16	Zenith Stromberg Carburetters: Overhaul	42
L.17	Zenith Stromberg Carburetters (Exhaust Emission) Description	47
L.18	Air Cleaner	51
L.19	Choke Control	52
L.20	Throttle Cable	52
L.21	Carburettor Fault Finding	53

Additional Information

L.22	Weber Carburetters Air Trumpet	55
L.23	Air Cleaner Trunking	56
L.24	Starter Housing (Exhaust Emission)	58
L.25	1971 Evaporative Loss Control	58
L.26	Dellorto Carburetters - Description	63
L.27	Dellorto Carburetters - Removing	72
L.28	Fuel Cut-off Valve	73

L.1 - GENERAL DESCRIPTION

The fuel system has a fuel tank located at the rear of the luggage compartment. A flush fitting filler cap is located on the rear left-hand panel, the filler pipe being connected to the tank by a short length of hose retained with clips. The fuel tank gauge unit is located in the rear face of the tank. Fuel ventilation is by breather pipes at each rear upper side.

A fuel pipe connects the fuel tank to a diaphragm type mechanical fuel pump mounted on the right-hand side of the engine and operated by the jackshaft. The fuel pump incorporates a gauze screen and an inverted sediment bowl. From the fuel pump a branched pipe delivers fuel to the carburetters.

Either two side draught Weber, or from Chassis No. 50/1280, two side-draught Zenith Stromberg carburetters are used (see respective sections dealing with carburetters and also 'TECHNICAL DATA').

The air cleaner is of the replaceable paper element type, mounted in the nose of the car forward of the radiator. A flexible hose connects the air cleaner to an airbox mounted on the carburetters.

The fuel gauge on the instrument panel registers the quantity of fuel in the tank with the ignition switched on. A low level warning lamp is incorporated in the gauge and will glow when the tank contents fall to  $1\frac{1}{2}$  Imperial gallons (1.8 U.S. gallons; 6.8 litres) or below.

L.2 - FUEL SYSTEM

To Clean

1. Remove the air cleaner and clean (Section L.17).
2. Disconnect the fuel supply pipe at both the carburetters and fuel pump locations.

Weber Carburetters

1. Unscrew the wing nuts and lift off the two main and idling jet covers. Remove the screws securing the carburetter covers and remove the two covers.
2. Remove the jets and blow them clean with an air line (Section L.10).
3. Clean the floats and float chambers with petrol and blow clean with an air line.
4. Refit the carburetter covers ensuring that the floats are free to move in their bodies. Replace the two main jet covers and secure with their wing nuts. Check float level.

Zenith-Stromberg Carburettors

1. Remove the carburettors from the engine (Section L.13).
2. With the carburettors off the engine, remove and clean the float chambers, floats and needle valve assemblies (Section L.15).
3. Refit the needle valve assemblies, the floats and float chambers. Ensure that the needle valves and floats are free to move. Refit the carburettors to the engine.

All Engines

1. Using an air line, blow through the previously dis-connected fuel supply pipes between carburettors and fuel pump. Replace the pipe.
2. Disconnect the pipe between the fuel tank and the fuel pump, and blow through using an air line. Replace the pipe.
3. Remove the fuel pump sediment bowl and filter, wash in clean petrol, and refit.
4. Replace the air cleaner.

L.3 - FUEL TANK

To Remove

1. From under the L/H side of the car and above the rear suspension upper wish-bone, remove the rubber grommet (not fitted on all models) from the body to expose the fuel tank drain plug. Some models are provided with a seal (W.0210) between the body and the tank. Using a funnel with rubber tube attached, release the plug and drain the petrol into a suitable container.
2. While still under the car, remove the fuel supply pipe from the tank.
3. From inside the boot, remove the boot floor and backboard (see Section B). Remove the cables from the fuel gauge sender unit, noting their locations. Release the rubber elbow connecting the fuel filter neck to the tank.
4. Remove the nuts from the ends of the tank retaining straps, fold the straps upwards, pull off the breather tubes from the rear upper sides of the tank, and pull tank from its location.

To Replace

1. Refit the drain plug into the tank ensuring that it is fully tightened.
2. Push the tank into its location after fitting seal (W.0210), ensure the rubber strips are correctly positioned, fold down the tank retaining straps and secure with their nuts and washers.
3. Refit the rubber elbow connecting the tank to the filler neck. Replace the breather tubes. Replace the cables to the fuel tank sender unit. If

1C-50-L1

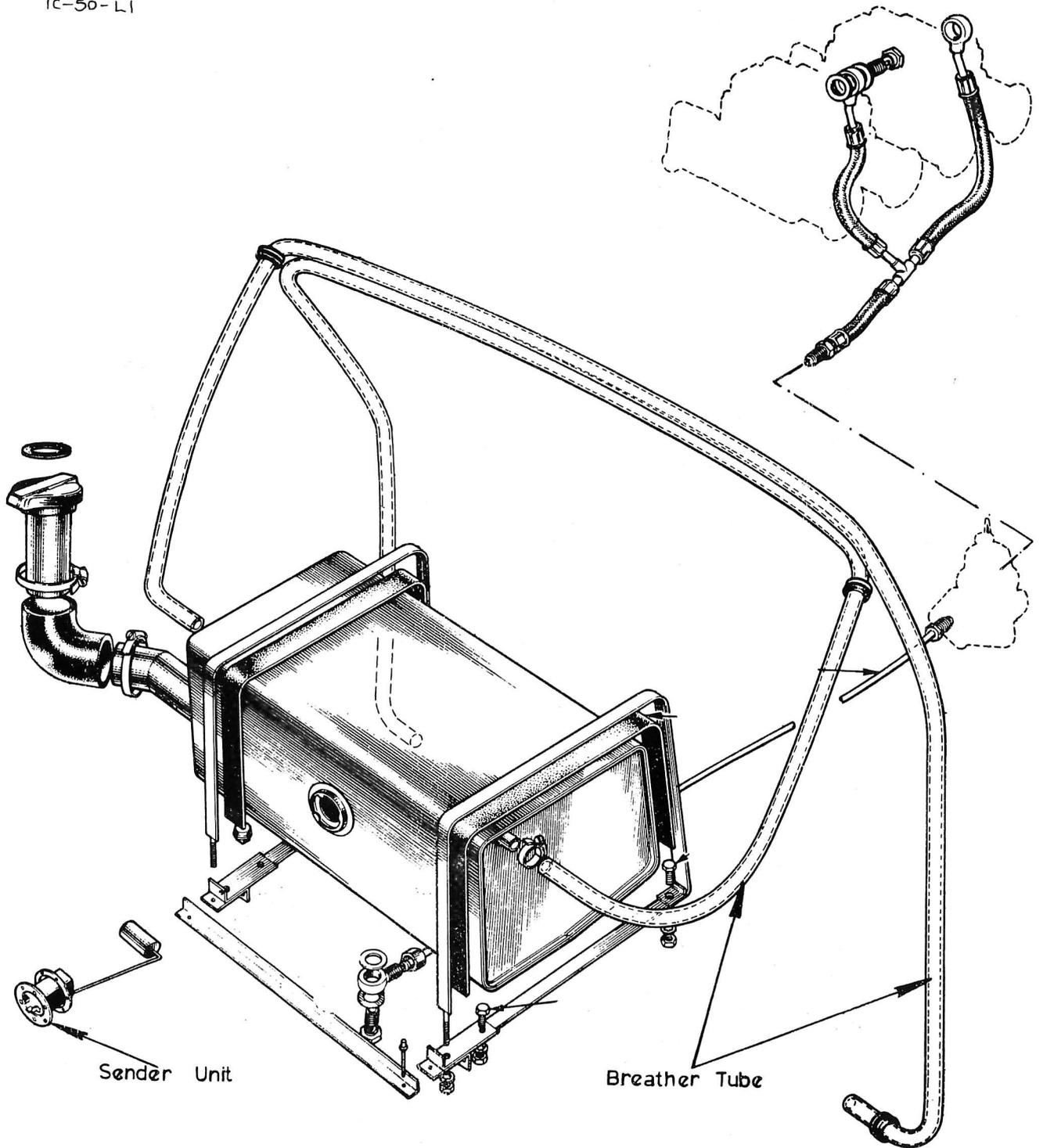

Fig.1. FUEL SYSTEM

IC-50-L2

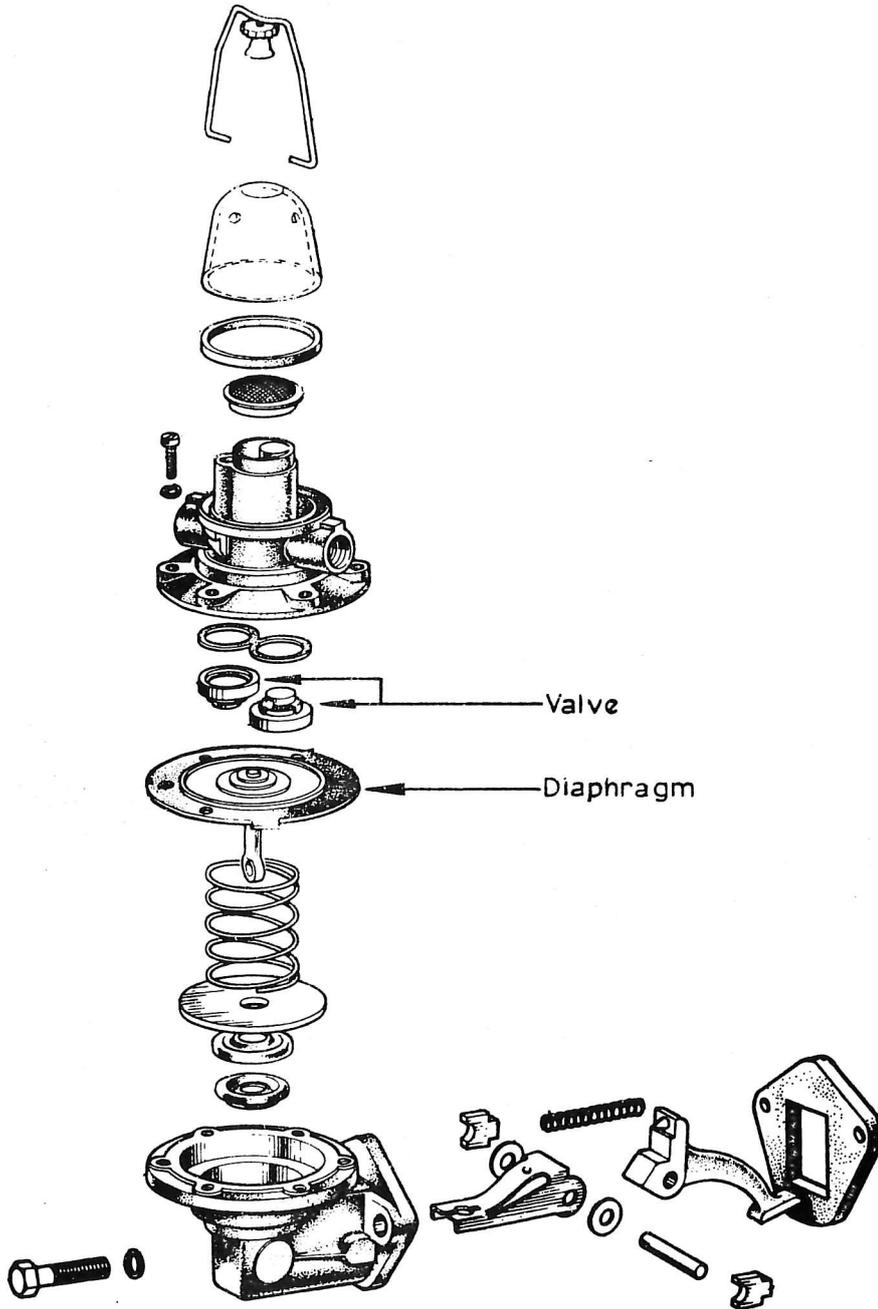

Fig. 2. FUEL PUMP COMPONENTS

disturbed, the body aperture through which the drain tube passes must be resealed with a continuous ring of 'Prestik' to prevent possible water entry. Replace boot backboard and floor.

From below the car, refit the fuel supply pipe to the tank. Replace rubber grommet (where fitted) concealing tank drain plug.

Fuel Tank Filler Neck

If gel-coat crazing of the bodywork has occurred in the vicinity of the filler neck, this being caused by the flexing of the rubber elbow, it can be rectified in the following manner:-

1. Fit bracket (Part No. 50B 1440) to the inside of the body in line with, and on centre-line of filler neck with 2 off tappits (Part No. 50 B 6052).
2. Secure filler neck to bracket with clip (Part No. 50 B6104).

Fuel Tank Breather Tubes

It is possible under certain conditions, particularly with a full load of fuel, that the breather tubes can become filled with fuel thereby causing difficulty in filling, but more important, the tank will not be able to vent (breathe) itself. In warm climatic conditions, when trapped air expands, it will force the fuel back up the filler neck and subsequently under the seal in the filler cap, eventually spilling out over the bodywork which could have disastrous consequences.

The reason for this is that the breather tubes are sometimes too long, the excess length of tube lying in the space within the body between the fuel tank and the body side.

To obviate this it is necessary to carry out the following procedure:-

1. Remove both the rear screen (backlight) and the rear parcel shelf (see Section B) which will expose the fuel tank and breather tubes.
2. Remove the rear seat cushion, squab and trim panel at each rear quarter (see Section B).
3. From each end of the fuel tank, release the tube retaining clips and remove the tubes.
4. Using a new 10 ft. (3.04m.) length of tubing connect one end to one side of fuel tank. Lay the tube over the tank to the other side of the car.
5. Lay the tube in the air extractor box. It will be seen that a hold must be made in the front face of the extractor box to enable the tube to be passed through. The tube is then passed vertically down the side of the body.
6. Another hole must now be made in the side face of the seat pan moulding so that the tube can protrude into the atmosphere. Secure the tube on the outside

face with a wire clip.

7. Carry out procedures 4, 5 and 6 on the other side of the fuel tank.
8. Ensure that the tubes are not 'kinked' or 'drooping' below the tank vent outlet pipe.
9. Cut off the visible original part of the breather tubes and discard.
10. Replace rear quarter trim panels, rear seat squab, rear seat cushion, rear parcel shelf and backlight.

#### Fuel Tank Filler Cap

The seal in the filler cap has been found to be liable to attack by certain fuels, which will cause leakage of fuel and subsequently deterioration of the paintwork.

To rectify, carry out the following procedure:-

1. Remove the fuel filler cap from the filler neck by extracting the hinge pin.
2. Remove the cap seat by carefully filing, or drilling off the belled end of the seat pillar. Remove the existing rubber seal and discard.
3. Fit a new seal (Part No. 50L 6008) and retain by drilling and tapping the pillar to accept a  $\frac{3}{8}$  in. (9.5 mm.) long x 2BA setscrew. Apply 'Loctite (AV)' to the screw before inserting.
4. Replace the filler cap on the filler neck.

#### L.4 FUEL TANK SENDER UNIT

##### To Remove

1. Drain the fuel from the tank into a suitable container. (See Section L.3)
2. Remove boot backboard. (See Section B.)
3. Make a note of the wiring positions, then remove cables from sender unit.
4. Unscrew the sender unit lock ring.

##### To Replace

1. Place a new sealing ring in the recess in the tank, then fit the sender unit tightening its lock ring with a suitable wrench.
2. Reconnect the cables to their correct locations on the sender unit.
3. Replace the boot backboard.

#### L.5 - FUEL GAUGE

##### To Remove

1. Remove the glove box (Section B).
2. From behind the fuel gauge, release the nut securing the gauge strap, pull off

strap and pull gauge out of facia panel from front.

3. Note position of wiring cables and remove from gauge.

To Replace

1. Reconnect cables to the fuel gauge, push gauge into location in facia panel.
2. From behind facia panel, replace securing strap with its nut.
3. Refit glove box.

L. 6 - FUEL PUMP

Description

Fuel is drawn from the fuel tank by the pump which is secured to the engine block and is driven by an eccentric on the jackshaft. The pump consists of two main bodies which clamp a diaphragm between their outer flanges.

The lower body assembly comprises a rocker arm and link, both of which pivot on a pin located in the body; attached to the link is the pull rod incorporated in the diaphragm assembly. To protect the diaphragm from crankshaft oil splash, an oil seal is located at the point in the lower body where the push rod passes through. A return spring is interposed between the undersides of the diaphragm and the lower body, the spring determining the pump output pressure, (See 'TECHNICAL DATA'). A further spring is fitted between the rocker arm and the body for the purpose of ensuring that the rocker arm is in constant contact with the eccentric on the jackshaft.

Assembled in the upper body are two valve assemblies <sup>oil</sup> being opened by suction, the other by pressure. Both valves are held in position by a recess in the upper body which is then staked.

Both inlet and outlet valve assemblies are identical in construction and are renewable and interchangeable.

Also incorporated in the upper body is a filter gauze which is held in position with a domed glass top cover and gasket, this in turn being held by a centre screw clamping the cover to the upper body.

To Remove Fuel Pump

1. Disconnect the pipes from the inlet and outlet bosses of the fuel pump. Seal off the ends of the pipes to prevent the ingress of foreign matter.
2. Remove two fuel pump retaining bolts and lockwashers, and withdraw fuel pump and gasket from cylinder block.

To Dismantle

1. Before commencing to dismantle, clean exterior of pump and scribe a line across the lower and upper body flanges of the pump for location purposes during re-assembly.
2. Remove domed glass top cover of pump also gasket and filter gauze.
3. Remove the screws and spring washers securing the lower and upper bodies together and separate the two bodies.
4. The valve assemblies are 'staked' in position and it is necessary to relieve this 'staking' in order to remove valves.
5. From the lower body remove the diaphragm and pull rod assembly, first turning the assembly through an angle of  $90^{\circ}$  in order to free the rod from the link in the rocker arm assembly.

NOTE: The diaphragm and pull rod are a permanent assembly and no attempt should be made to separate the two parts.

6. Lift out the diaphragm return spring and where fitted, remove oil seal retaining washer and oil seal.
7. Providing that the rocker arm pin is held firmly in the lower body it should not be necessary to remove the rocker arm pin or associated parts unless undue wear is in evidence.

Should it be necessary to remove the rocker arm from body, the following procedure should be adopted:

The rocker arm and associate parts are located by two retainers, which are fitted into slots at engine face of castings, the retainers in turn being held by punch indentions at each end of retaining pins.

To remove the rocker arm assembly, hold rocker arm firmly in suitable vice and with two flat bars, approximately 12 in. long, (30.5 cm.) insert one in the gap each side of the casting and vice, lever the body away from the rocker arm and pin.

NOTE: Care should be taken that the type of removing bars used are flat to ensure that the body machined face is not damaged.

Inspection and Overhaul

1. Thoroughly wash all parts in clean paraffin, ensuring that valves are cleaned separately if being used again.
2. Check the diaphragm for hardening or cracking and examine the lower extremity of the pull rod, where it connects with the rocker arm link, for wear. Renew the diaphragm assembly if any of these signs are in evidence.
3. Check diaphragm return spring, if corroded damaged, it should be replaced.

4. Visually check valve assemblies, if any doubt exists, replacement valves should be fitted. The two valves are identical and can be used for either application by inverting their positions.
5. Examine the rocker arm face pad for wear. Slight wear is permissible but should not exceed a depth of .010in. (.254 mm.).  
Check rocker arm pin and link holes for wear, also the underside of link where diaphragm pull rod engages for wear.  
Badly worn or damaged parts should be renewed.  
Check rocker arm return spring.
6. Discard old oil seal and gaskets.
7. Examine upper and lower bodies for cracks or damage. If either the diaphragm or engine mounting flanges are distorted, these should be lapped to restore their flatness. Renew if either distortion is excessive.

To Re-assemble

The re-assembly of the rocker arm into the body is as follows:  
Assembly rocker arm, link and spacing washers onto rocker arm pin, place rocker arm return spring into body and insert rocker arm assembly into body of pump. Ensure that the rocker arm return spring is properly engaged between locating 'pips' on casting and rocker arm. Tap two new pin retainers into slots in the body and while holding the retainers hard against the rocker arm, pin punch over the end of the slots with a  $\frac{1}{8}$  in. (3.17 mm.) pin punch to prevent retainers working loose.

NOTE : When refitting rocker arm pins, always use new service replacement retainers (coloured copper for identification). These are slightly shorter than the original type to allow for new staking.

Fit new oil seal washer and steel retaining washer into the lower body.

Place the diaphragm return spring in position over oil seal retaining washer.

Place the diaphragm assembly over the spring, with the pull rod downwards and with the locating tab on the diaphragm at the twelve o'clock position. Press down on the diaphragm at the same time turning the assembly to the left in such a manner that the slot on the pull rod will engage the fork in the link, ultimately turning the assembly a complete quarter of a turn to the left, which will place the pull rod in its correct working position in the link.

This will also permit the matching up of the holes in the diaphragm with those on the pump body flange and the tab will now be at nine o'clock position.

Place the new valve gasket in the upper body around the valve ports. Place valve assembly in inlet port with spring facing outwards. Fit other valve in the outlet port position with spring inside the port.

When refitting re-stake valve in four positions by using a suitable punch.

Refit filter gauze in top of upper body also glass domed cover with new cover gasket. Fit central clamping screw.

The upper and lower bodies can now be fitted together as follows:

Push the rocker arm towards the pump body until the diaphragm is level with the body flange.

Place the upper half of the pump body into its correct position by aligning the scribed lines made on the two flanges prior to dismantling.

Replace the securing screws and spring washers and tighten only until the heads of the screws engage the washers.

Push the rocker arm away from the pump so as to hold the diaphragm at the top of the stroke and while so held, tighten the body screws diagonally and securely.

IMPORTANT: After assembling in the manner described above, the edges of the diaphragm should be flush with its two clamping flanges.

Any appreciable protrusion of the diaphragm indicates incorrect fitting in which case, special care should be taken in maintaining downward pressure on the rocker arm while the diaphragm screws are finally tightened.

#### To Replace

1. Clean the mounting face on the cylinder block, removing any trace of gasket which may be adhering to the face. Fit a new gasket to the cylinder block flange, holding it in place with a smear of grease.
2. Insert the rocker arm through the hole in the cylinder block so that the arm lies on the camshaft eccentric.
3. Secure the fuel pump to the cylinder block with two spring washers and bolts, tightening the bolts evenly to the torque loading given in 'TECHNICAL DATA'.
4. Ensure that the pipe joints are clean and refit the fuel pipes.
5. Run the engine and check for leaks at the joints.

### L.7 - WEBER CARBURETTERS

#### General Description

These carburetters are of the dual barrel side-draught type, each consisting of two single barrel carburetters with two venturis in each barrel. A small auxiliary venturi is located in each barrel and they discharge fuel, except under certain conditions, into the narrowest portions of the large venturis. By using two venturis in each barrel a greater depression is created than when a single venturi is employed. Also, the velocity of an airstream is higher at the centre, and the velocity of

this central core is used by the auxiliary venturis, which discharge into the centre of the main venturis at the narrowest section.

The throttle plates in each carburetter are on a common spindle and the synchronising linkage between the carburetters ensures that the throttle plates in each carburetter open an identical amount. It should be remembered that one barrel supplies one cylinder only, since the inlet tracts are not interconnected. Apart from the throttle linkage, the carburetters are identical and each carburetter is, in effect, two carburetters with duplicated main jets, idling jets, etc.

However, whilst each barrel has an accelerator pump jet there is only one piston type accelerator pump per carburetter and this feeds both jets. To facilitate cold starting a progressive starting device is fitted, discharging the mixture into both barrels on the engine side of the throttle plates. The idling jets, main and air correction jets, together with their emulsion tubes, are accessible after removing the small circular cover retained by a wing nut on top of the carburetter cover.

A common float chamber is incorporated in each carburetter with twin floats, to reduce the effects of fuel surge, actuating a single needle valve which incorporates a damping device to prevent the needle from chattering on its seat. The floats straddle the centrally located jets, their position reducing the effects of fuel surge which occurs when cornering, braking and accelerating. A gauze filter is fitted between the fuel entry point in the carburetter cover and the float chamber.

The following operating details apply, for simplification purposes, to one barrel of a carburetter. The supply to the other barrel is the same.

#### Cold Starting

The progressive starting device on one side of the carburetter is actuated by the choke control on the instrument panel. It consists of two spring-loaded pistons, operated by a single lever connected to the choke control, which opens or closes a duct to each throttle barrel, and two petrol starting and air corrector jets, supplied with petrol from the float chamber and air from the float chamber respectively.

With the engine being cranked by the starter motor and the pistons raised from their seats by the action of pulling out the choke control on the facia panel, petrol passes from the float chamber through the starting jet and is emulsified by air from the calibrated bush in the carburetter body. This mixture is then ducted to the piston chamber at a point below the piston where it meets further air passing through two holes, uncovered by the piston, which are open to atmosphere. The mixture is then ducted to an orifice on the engine side of the throttle plate.

When the engine starts and the choke control is pushed progressively home as the engine warms up, the piston will move closer to its seat and orifice at the top of the piston chamber will be uncovered thus allowing a greater quantity of air to enter through the starting device piston spring guide/retainer. At the same time, the orifice below the piston which supplies the mixture from the starting jet is partially blanked and so are the holes open to atmosphere, thus reducing and weakening the quantity of mixture delivered.

With the choke control pushed fully home the piston will be returned to its seat and close the duct to the barrel.

#### Idling and Progression Supply

Petrol passes from the float chamber to the idling jet and is emulsified with air from the float chamber. The orifice in the tapered end meters the petrol and the hole in the side of the idling jet calibrates the air. The mixture passes through the holes in the idling jet holder and via passages is ducted to the idling discharge orifice on the engine side of the throttle plate. The quantity of mixture passing through the discharge hole is regulated by a needle type volume control screw.

Three progression holes by the throttle plate edge are connected to the passage supplying the idling mixture. These progression holes ensure a smooth and progressive supply of mixture as the throttle plate is gradually opened.

#### Main System

The emulsion tube is a push fit in its holder. In one end of the emulsion tube is the air corrector jet and in the other end the petrol jet.

When the throttles are opened further, depression is imposed on the auxiliary venturis. Petrol passes from the float chamber through the main jet into the emulsion tube where it mixes with air which has passed through the air corrector jet.

The mixture is then channelled to the 'beak' in the auxiliary venturi which in turn discharges into the main venturi.

#### Accelerator Pump System

The accelerator pump ensures smooth acceleration and reduces any hesitation when the throttle is suddenly opened.

The single accelerator pump in each carburetter supplies two pump jets, one per barrel. Only one inlet valve is fitted but there are two delivery valves.

With the throttle plates closed the accelerator pump control rod is raised by the arm pinned to the throttle plate spindle. The control rod, which is 'U' shaped, and the piston are spring-loaded so that if the throttle spindle arm is lowered the pump piston will descend under the action of its own spring.

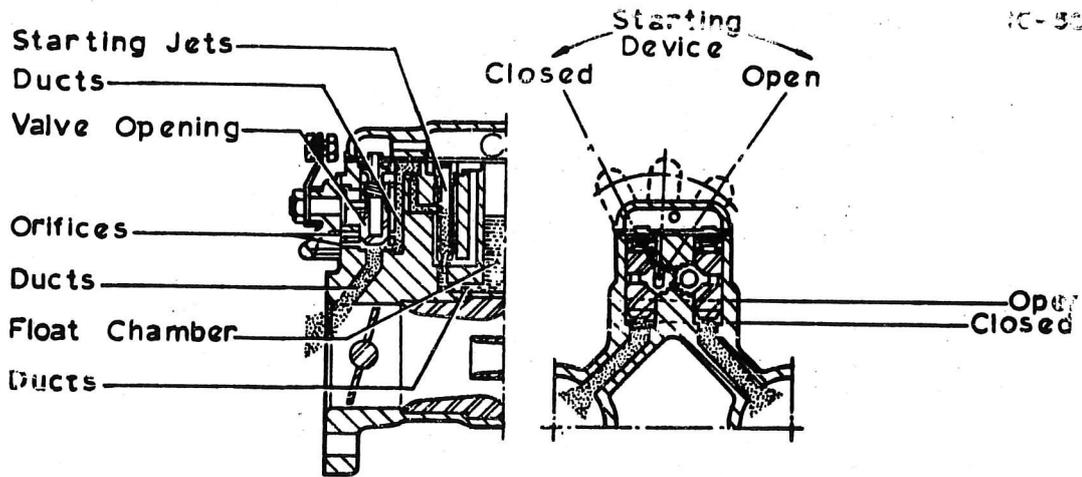

Fig. 3. STARTING DEVICE (WEBER)

IC-50-L4

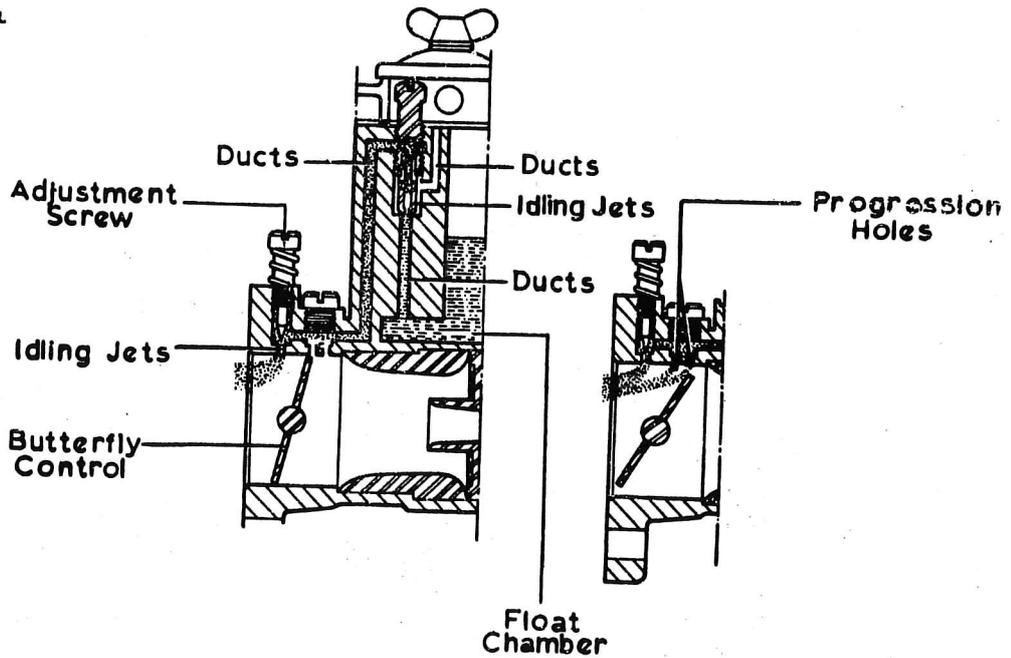

Fig. 4. IDLING & PROGRESSION SUPPLY (WEBER)

IC-50-L5

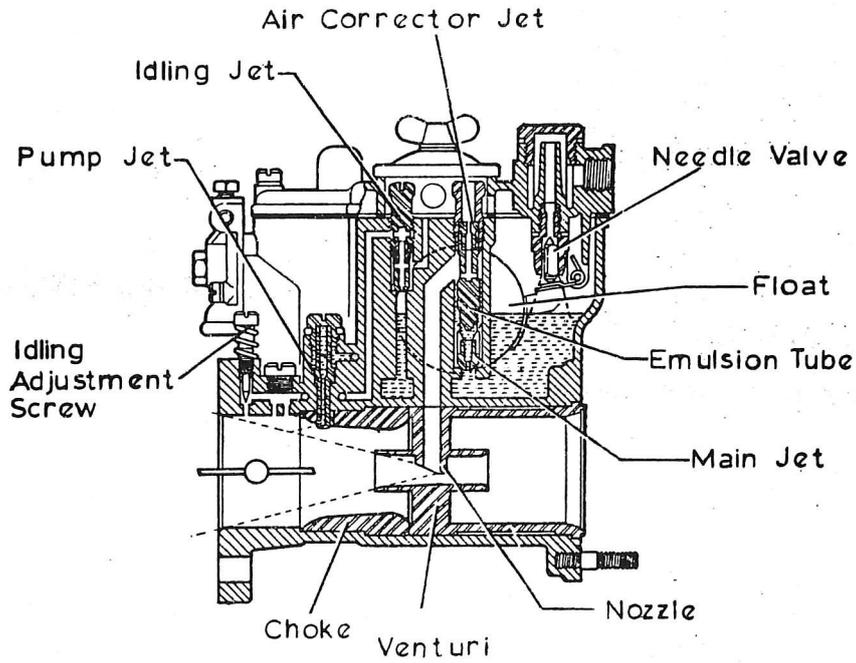

Fig. 5. MAIN SYSTEM  
(WEBER)

IC-50-L6

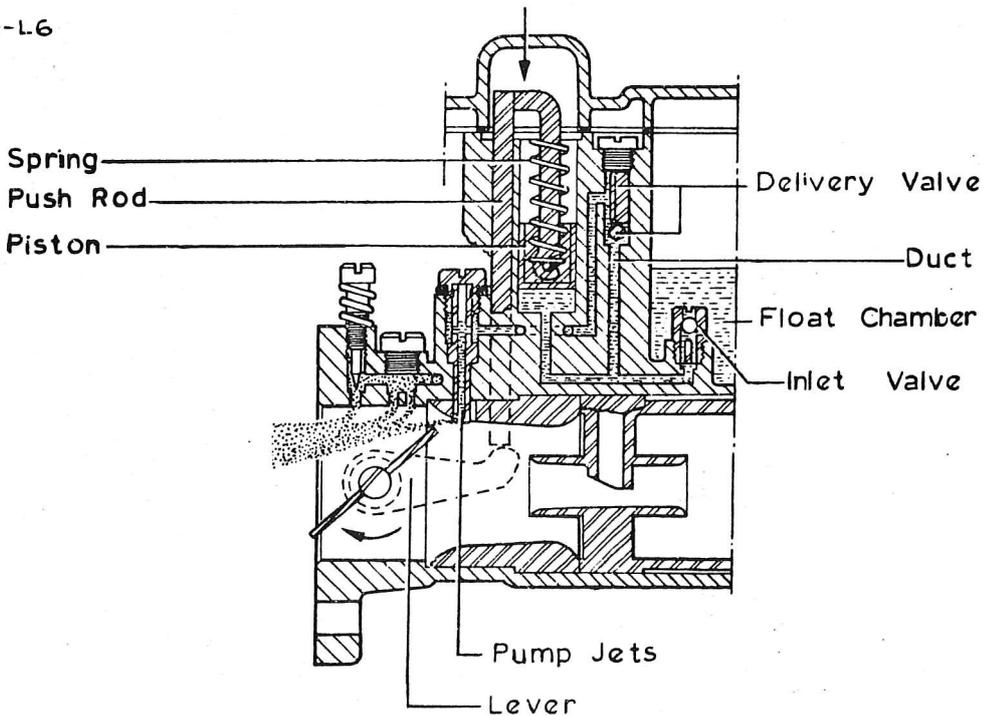

Fig. 6. ACCELERATOR PUMP SYSTEM  
(WEBER)

When the piston ascends petrol is drawn from the float chamber past a ball in the inlet valve located in the bottom of the float chamber. This inlet valve has a lateral calibrated orifice which passes any excess fuel into the float chamber when the piston descends.

When the throttles are opened, the spindle rotates the arm which allows the pump control rod and piston to descend under the action of their spring. The inlet ball valve closes, preventing fuel from returning to the float chamber, except by calibrated orifice. Petrol is then forced to a pump delivery valve, lifts the weighted ball from its seat in the carburetter body and then passes to the appropriate pump jet, mounted between the edge of the main venturi and throttle plate.

When the accelerator pedal is released the vacuum caused when the pump piston rises closes the delivery valve ball to prevent the entry of air through the pump jet. The pump cylinder is therefore refilled by fuel flowing past the inlet ball valve and lateral calibrated orifice.

#### High Speed Device

To slightly enrich the mixture at high engine speeds the accelerator pump delivery valve performs as a power jet. When the vacuum at the pump jet reaches a certain value, according to the delivery valve ball weight, the ball is drawn from its seat and, via the accelerator pump housing and inlet valve, fuel is drawn from the float chamber.

#### Carburetter Flexible Mountings

Studs are screwed into the flanges of the inlet tracts, and these studs pass through the spacer, the carburetter mounting flanges, double coil spring washers and the nuts. 'O' rings are sandwiched between the carburetters, spacers, and the inlet tracts. The 'O' rings act as a seal to prevent the ingress of air, and together with the double coil spring washers, also act as an insulator to absorb vibration and prevent frothing in the float chambers.

At every 'A' Service (see Section 'O') check the clearance, with feeler blades, between the coils of the eight spring washers. The clearance should be .04 in. (1.01 mm) and it must be remembered to check also the four washers which are below the carburetters. If only the top four washers are set and those underneath are loose the carburetters will tilt with the possibility of air leaks and the 'O' ring being pulled from its mounting plate and barrel.

To obtain the correct clearance slacken or tighten the carburetter retaining nuts. Be careful not to overtighten the nuts, otherwise the mounting plate may

permanently be distorted and the 'O' ring can then become detached. Also, the coil spring washer may fracture if over-tightened.

### L.8 - WEBER CARBURETTERS

#### To Remove

1. Release the clip and disconnect the air cleaner trunking from the air box. Remove the central bolt visible in the air box, and pull off the outer half of the box.
2. Unhook the throttle return spring and remove throttle cable from carburetters. Disconnect the fuel supply pipes at the carburetters. Remove the choke cable.
3. Progressively release the carburetters securing nuts, (four are visible from above, the other four being below). Remove nuts and washers.
4. Carefully remove the two carburetters as an assembly, ensuring that the synchronising linkage between the two is not distorted. Remove the spacers with their 'O' rings from the mounting studs.

#### To Replace

1. Carefully examine to check that each carburetter metal spacer is not damaged, and that the 'O' rings in the faces of the plate are in position. Fit the spacer assemblies.
2. Fit the carburetters, ensuring that the synchronising linkage is correctly positioned so that the lug on the rear carburetter throttle linkage is between the spring-loaded plunger and adjusting screw on the front carburetter. To each stud fit a double coil spring washer, a flat washer and nut. Tighten the eight nuts progressively until a .040 in. (1.02 mm.) clearance exists between the carburetter flange and spacer. This clearance should be checked with feeler blades. Do not overtighten the nuts otherwise the 'O' rings will be flattened into the recesses of the plate.
3. Refit the fuel supply pipes to the carburetters. Reconnect the choke control by securing the cables casing in the case arm of each starting device cover with the clamp screw. Ensure that the choke control on the facia panel is pushed fully home and that the starting device operating levers are in the off-position.
4. Reconnect the throttle cable and throttle return spring.
5. Ensure the gasket is in good condition between the two halves of the air box, then refit outer half. Reconnect the air trunking to the air box.

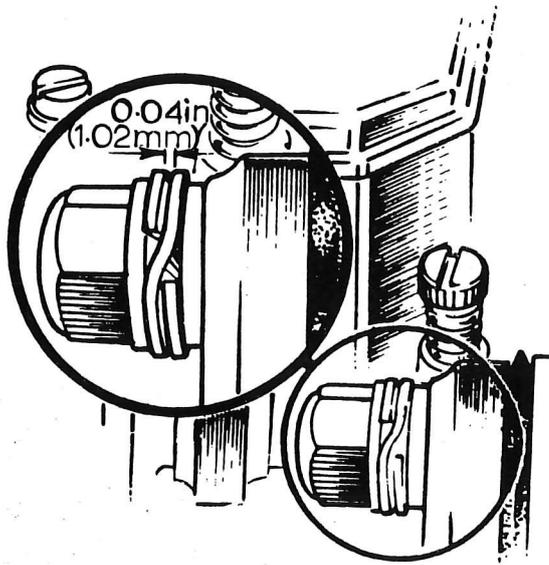

Fig. 7. DOUBLE COIL SPRING WASHER CLEARANCE (WEBER)

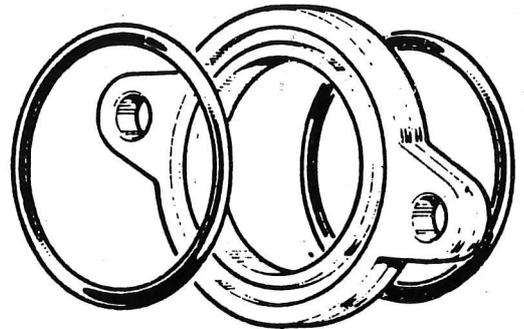

Fig. 8. CARBURETTER FLEXIBLE MOUNTING (WEBER)

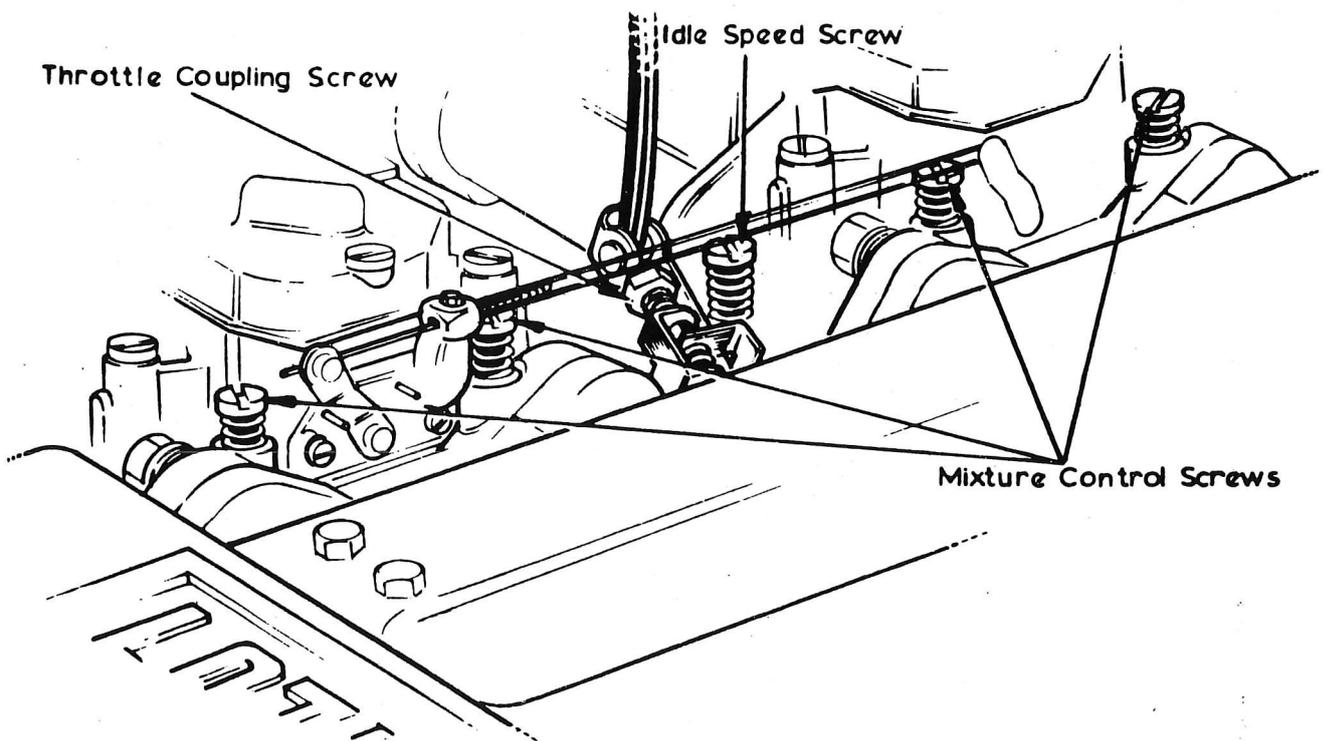

Fig. 9. CARBURETTER ADJUSTING SCREWS (WEBER)

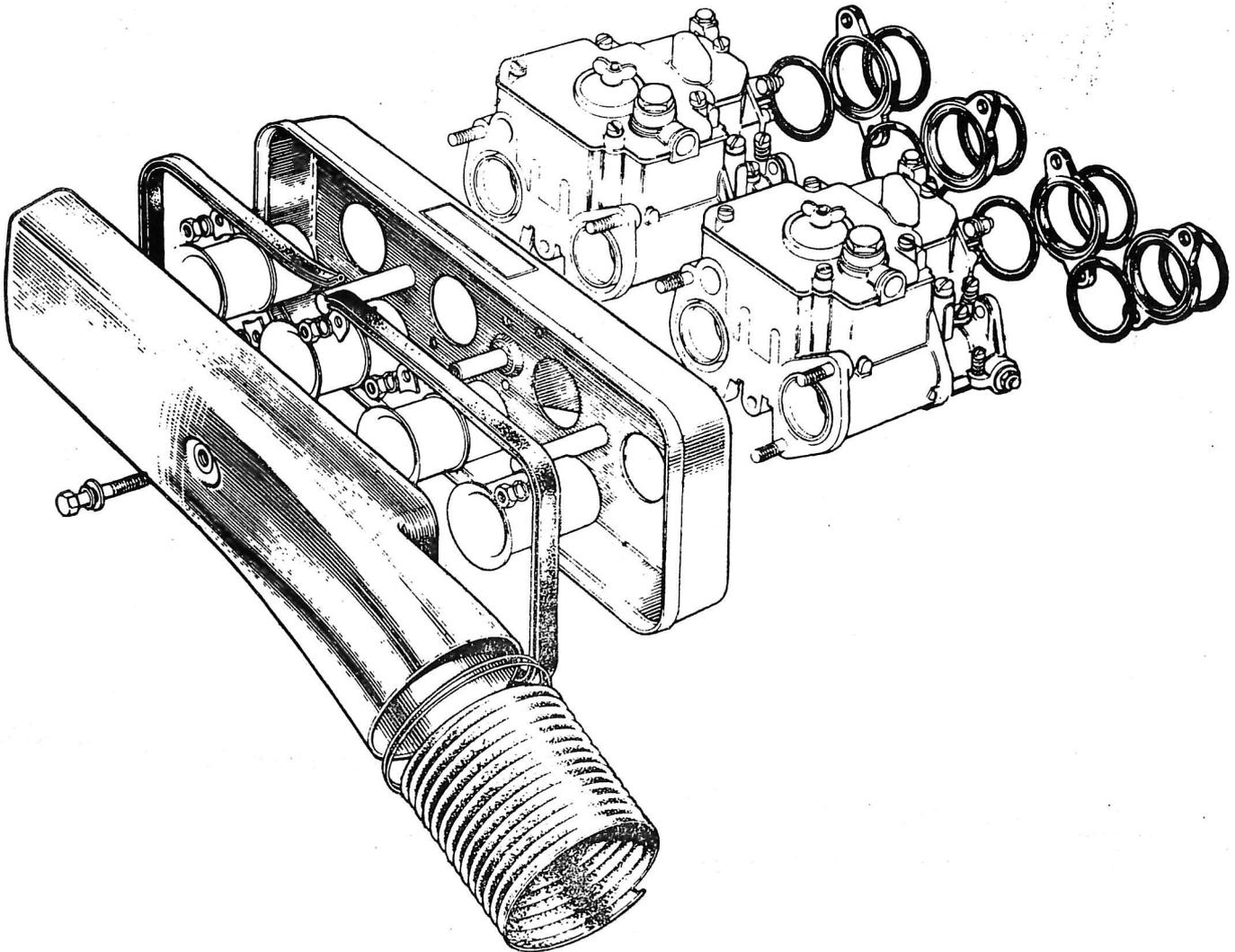

Fig.10. AIR BOX & CARBURETTER ASSEMBLY

L.9 - WEBER CARBURETTERSTo adjust

The only adjustments required are synchronisation, mixture strength, and idling speed. These adjustments being effected by the idle speed adjustment screw (or throttle screw) the interconnecting throttle arm screw (or coupling screw) and the four idling mixture volume adjustment screws (or mixture screws).

The carburetters should be 'set-up' after initial installation or subsequent overhaul as follows:

1. Ensure the engine has reached its normal running temperature and check that the starting control (choke) levers, are fully forward. The warmer the engine the easier the adjustment will be.
  2. Check that there are no air leaks at the 'O' ring gaskets.
  3. Set all four mixture screws approximately three-quarters turn open.
  4. Adjust the rear carburetter throttle screw to give approximately 1000 r.p.m.
  5. Synchronise the carburetters. This is done as follows:-
    - (a) Using a proprietary carburetter balancing tool (such as the Crypton Synchro-Test) adjust the coupling screw until the air flow through each carburetter is the same. Alternately a piece of rubber or plastic tube can be used; one end being held to the ear and the other at the mount of the carburetter trumpet. The coupling screw is then adjusted to produce the same loudness of 'hiss' at each carburetter.
    - (b) Short out or remove each plug lead in turn and adjust the coupling screw until the shorting out of each pair of plugs produces approximately the same drop in engine revs.
- NOTE: For method (a) it is necessary to remove the airbox cover but this will have negligible effect on the carburation at idling speeds.
6. Adjust each mixture screw in turn. One at a time, screw each one right in and unscrew a small amount at a time (not more than  $\frac{1}{8}$  turn waiting approximately 5 seconds at each setting. A point will be found which will cause a rise in engine revolutions and continued unscrewing beyond that point will cause the revolutions to drop back again. Each screw must be adjusted to give the maximum rise in revolutions. The rise in revolutions may be so small (possibly 50 r.p.m. or so ) as to be undetectable by ear, and it is recommended that a mirror should be hung on the steering wheel so that the tachometer may be seen.
- NOTE: During the course of items 5 and 6 it will be necessary to re-adjust the throttle screw from time to time to maintain the engine revolutions at around 1,000 r.p.m.
7. Repeat 4, 5 and 6 (possibly several times ) until no further improvements can be obtained.

8. Adjust the throttle screw to give an idle of 800 to 900 r.p.m.

**NOTE:** In all cases where there may be unbalance of air flows through throttles in the SAME carburetter, this can be corrected by placing a spanner on each end of the throttle spindle, and twisting slightly in the required direction.

### L.10 - WEBER CARBURETTERS

#### To Clean

1. Disconnect the fuel supply pipes at the carburetters. Unscrew the wing nuts and lift off the two main and idling jet covers. Progressively, release the screws securing the top covers, remove screws with their washers and remove covers.
2. Remove the accelerator pump inlet valve from the base of the float chamber.
3. Remove the idling jet holders (two per carburetter) and pull the jets from the holders.
4. Unscrew the emulsion tube holders (two per carburetter). Pull each emulsion tube from its holder and then the main jet from one end of the emulsion tube and the air corrector jet from the other.
5. Remove the accelerator pump delivery valve retaining screws (two per carburetter).
6. Unscrew the pump jet retaining screws (two per carburetter) and examine the rubber seal around each screw. Extract each pump jet from the body.
7. Remove the starting jets (two per carburetter).
8. Remove the accelerator pump from the carburetter body. Pull out the inverted 'U' shaped control rod which will withdraw the split retainer, spring and piston.
9. Blow the accelerator pump, the jets and their housings clean using a low pressure air line. Wash the floats and the float chambers in clean petrol and blow clean.
10. Fit the starting jets.
11. Replace the accelerator pump jets, noting that the smaller diameter enters first and the flat on the large diameter is to the engine side of the carburetter. Check the condition of the retaining screw rubber seals and refit together with these screws.
12. Refit the accelerator pump delivery valves by fitting a ball first, then a weight concave face to the ball, and finally the retaining screws.
13. Fit the emulsion tube holders. Push a hexagonal head main jet into the large diameter end of an emulsion tube and a circular-headed air corrector jet in the other end. Fit the emulsion tube holder over the air-corrector end, and screw the assembly into position.

14. Replace the idling jets in their holders and fit them in the carburetter.
15. Check that the accelerator pump inlet valve ball moves freely and screw the valve into the base of the float chamber.
16. Reassemble and fit the accelerator pump. Slide the split retainer on the accelerator pump control rod, with the dishing toward the hook end of the control rod. Pass the spring over the hooked end of the control rod, compress the spring and then locate the piston on the control rod. Position the assembly in the carburetter and press the split retainer into position.
17. Refit the carburetter cover, ensuring that the floats are free to move in the bodies. Secure them with their screws and washers tightening them evenly. Refit the small circular main and idling jet covers retained by wing nuts. Reconnect the fuel supply pipes to the carburetters.

L.11 - WEBER CARBURETTERS

Overhaul

1. Remove the carburetters from the engine (Section L.8), then with the instruments on a clean bench, remove the nuts, spring washers and clamps which secure the trumpets and the air box backplate to the carburetters.

To Dismantle

1. Remove the auxiliary venturi followed by the main venturi from each barrel.
2. To remove the fuel filter unscrew the hexagon-headed retainer from the carburetter cover, noting that there is a sealing washer beneath the retainer head. Withdraw the gauze filter from the cover, taking care not to mislay the brass seat in the top of the filter.
3. The carburetter cover can be withdrawn after removing the small circular main and idling jet cover retained by a wing nut and then the screws (slacken evenly) with their washers.
4. Remove the floats and needle valve from the cover. Gently push out the float fulcrum pin from the cover, after which the needle valve may be removed from its seat.

Withdraw the cover gasket and unscrew the needle valve seat from the cover, a sealing washer being fitted between the needle valve seat and cover.

5. Remove the accelerator pump from the carburetter body. Pull out the inverted 'U' shaped control rod which will withdraw the split retainer, spring and piston. To dismantle the assembly, first compress the spring, slightly rotate the piston and withdraw from the hooked end of the control rod, followed by the spring and split retainer.

6. Unscrew the accelerator pump inlet valve from the base of the float chamber. Shake the inlet valve to ensure that the ball inside the valve body slides freely.
7. Remove the idling jet holders (two per carburetter) and pull the idling jets from the holders.
8. Unscrew the emulsion tube holders (two per carburetter). Pull each emulsion tube from its holder and then the main jet from one end of the emulsion tube and the air corrector jet from the other.
9. Remove each accelerator pump delivery valve retaining screws (two per carburetter) and invert the carburetter to extract the balls and weights.
10. Unscrew the pump jet retaining screws (two per carburetter) and examine the rubber seal around each screw. Extract each pump jet from the body.
11. Remove the starting jets (two per carburetter).
12. Unscrew the volume control screws and throttle stop screw, if fitted. Examine the springs.
13. The starting device cover on the side of the carburetter may be removed after unscrewing the two retaining screws which have spring and flat washers beneath their heads.
14. Carefully prise out the combined starting device piston spring guide/retainer circlips (two per carburetter). Withdraw the guides and springs and invert the carburetter to extract the starting device pistons.
15. Remove the throttle plates, one from each barrel, by unscrewing the two screws securing each plate in its shaft.
16. Remove the throttle spindle; a new carburetter body is supplied complete with the throttle spindle, pump operating arm, bearings etc. They can be dismantled, if required, as follows. Remove the nuts, after bending back the tab washers, each end of the throttle spindle. Remove the flat washer from one end and the throttle linkage from the other. Withdraw the plate and gasket, secured by two screws, from the engine side of the carburetter to gain access to the accelerator pump control arm. Tap out the pin retaining this arm to the spindle. Ensuring that the threads are not damaged, knock out the spindle which will also remove from one end of the spring retainer, the spring, dust cover and bearing. After dust cover can be extracted.

#### Cleaning and Inspection

After dismantling and prior to reassembling, the carburetter, filter and the jets should be cleaned and checked for size, see 'TECHNICAL DATA'. The seating of the idling jets, starting jets, starter pistons, and main jets in the carburetter body should also be examined, together with the seating faces of the jets and tubes them-

It is physically impossible to inter-change air correction jets with main jets, starting jets with idling jets etc., and similarly their positions in the carburetter.

Inspect the various gaskets, also the sealing rings fitted to the accelerator pump jet screws, needle valve seat and filter retainer. Clean the filter and ensure that the gauze is undamaged.

Shake the accelerator pump inlet valve to check that the ball is free to slide.

### To Reassemble

1. If removed, refit the throttle spindle across the barrels, ensuring that accelerator pump operating arm is fitted on the shaft so that the shouldered end is by a barrel and the curved end of the arm is uppermost. Retain the arm spindle with a tension pin. Fit a dust cover, spring and spring retainer at each end of the shaft and, depending on the end of the shaft, fit a flat washer on the throttle linkage. Secure with new tab washers and nuts, operating the throttle spindle whilst tightening the nuts to ensure ease of movement. It may be necessary to lightly tap either end of the shaft to obtain this condition. Refit the accelerator arm access plate and gasket, securing with two screws.
2. Fit the throttle plates, noting that the edges of the plates are chamfered, the plates being fitted so that they can completely close the barrels. If a new throttle plate is being fitted check that the angle stamped on the plate is  $79^{\circ}30'$ . If a throttle plate with a different angle is fitted then the carburetter's low speed progression will be affected since the distance between the throttle plate's edge and adjacent progression hole will be altered with the result that vacuum at the progression hole will either be too strong or too weak with consequential irregular running. Retain the plates in the shaft with new screws, the shaft holes being countersunk for the heads; do not tighten these screws at this time. Close the throttle shaft to centralise the plates with the barrels, tighten the screws and peen the threaded ends to retain.
3. Using a .002 in. (5.08 mm.) thick feeler gauge in the gap between the throttle body and the throttle plate (on the centre line of the throttle plate and at right-angles to the throttle spindle) at the progression hole side of the throttle barrel, hold the throttle control lever firmly against the stop screw and adjust the screw until a light pull is required to withdraw the feeler blade. Next, trap the feeler blade on the opposite side of the throttle plate and if the concentricity is correct then the same effort will be required to withdraw the blade with the stop screw in the same position. If the concentricity is incorrect the clamping screws must be backed off and plate moved as required.

IC-50-L II.

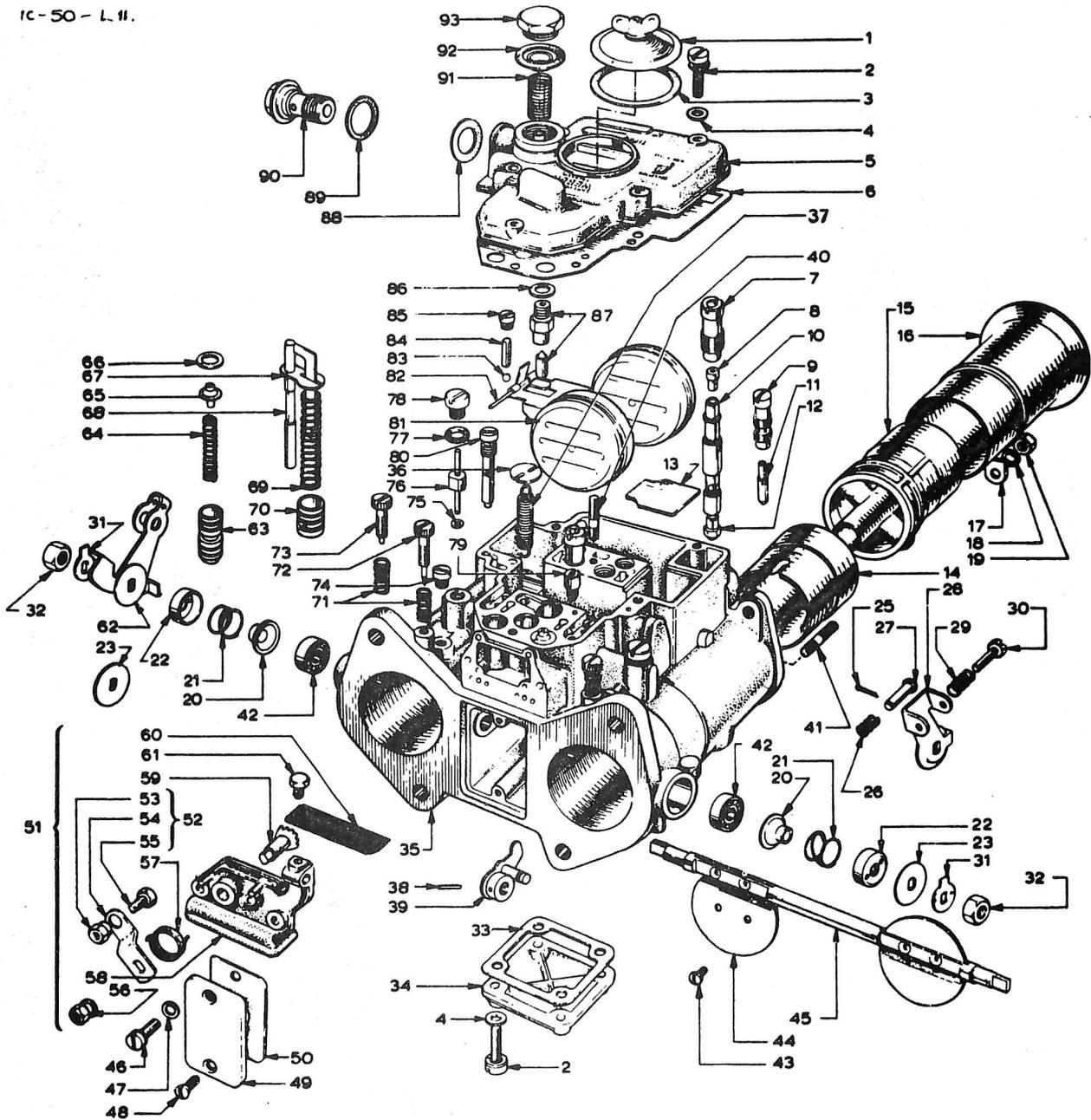

Fig. 11. WEBER CARBURETTER COMPONENTS

Key to Fig. 11.

- |                               |                            |                             |
|-------------------------------|----------------------------|-----------------------------|
| 1. Cover, jets inspection.    | 33. Gasket, bowl.          | 65. Guide.                  |
| 2. Screw.                     | 34. Cover, bowl.           | 66. Circlip.                |
| 3. Gasket. cover.             | 35. Body, carburetter.     | 67. Plate, spring retainer. |
| 4. Washer.                    | 36. Plate.                 | 68. Rod, pump control.      |
| 5. Cover, upper body.         | 37. Spring.                | 69. Spring.                 |
| 6. Gasket. cover.             | 38. Pin.                   | 70. Plunger.                |
| 7. Holder, emulsion tube.     | 39. Lever, pump control.   | 71. Spring.                 |
| 8. Jet, air corrector.        | 40. Stud, upper body.      | 72. Spring.                 |
| 9. Holder, idling jet.        | 41. Stud, trumpet to body. | 73. Screw, throttle adjust: |
| 10. Tube, emulsion.           | 42. Bearing.               | 74. Screw.                  |
| 11. Jet, idling.              | 43. Screw, throttle plate. | 75. Gasket.                 |
| 12. Jet, main.                | 44. Throttle plate.        | 76. Jet, pump.              |
| 13. Plate.                    | 45. Shaft.                 | 77. Gasket.                 |
| 14. Choke.                    | 46. Screw.                 | 78. Plug.                   |
| 15. Venturi.                  | 47. Washer.                | 79. Valve inlet.            |
| 16. Trumpet.                  | 48. Screw.                 | 80. Jet starting.           |
| 17. Plate, fixing.            | 49. Plate.                 | 81. Float.                  |
| 18. Washer, spring.           | 50. Gasket.                | 82. Shaft.                  |
| 19. Nut.                      | 51. Control assy.          | 83. Ball.                   |
| 20. Cover, dust.              | 52. Lever.                 | 84. Ball.                   |
| 21. Spring.                   | 53. Nut.                   | 85. Screw.                  |
| 22. Lid.                      | 54. Lever.                 | 86. Gasket.                 |
| 23. Washer, distance.         | 55. Screw.                 | 87. Seat needle valve.      |
| 24.                           | 56. Nut.                   | 88. Gasket.                 |
| 25. Pin, split.               | 57. Spring, lever return.  | 89. Gasket.                 |
| 26. Spring, throttle control. | 58. Cover.                 | 90. Banjo bolt.             |
| 27. Pin, control lever.       | 59. Shaft, starting.       | 91. Filter, upper casing.   |
| 28. Lever.                    | 60. Strainer.              | 92. Gasket.                 |
| 29. Spring, control lever.    | 61. Screw.                 | 93. Plug.                   |
| 30. Screw, control lever.     | 62. Lever, rear carb.      |                             |
| 31. Lockwasher.               | 63. Valve.                 |                             |
| 32. Nut.                      | 64. Spring.                |                             |

Repeat the above procedure on the second throttle plate until concentricity is obtained on this also. Peen the threaded ends of the screws to retain them.

4. Having checked (and set if necessary) the concentricity of the two throttle plates they should now be checked for synchronisation. Using a .002 in. (5.08 mm.) feeler blade positioned between the throttle body and the plate on the progression hole side of the barrel and holding the throttle control lever hard against the stop screw adjust the screw until a light pull is required to withdraw the feeler. Without disturbing the stop screw, the same effort should be required to withdraw the feeler from between the second plate and throttle barrel. In cases where the concentricity of the two throttle plates has been set but synchronisation is incorrect, check first that all the throttle plates are identical in respect to the degree number stamped on them (i.e.  $79^{\circ}30'$ ). If these are correct this normally indicates a twisted throttle spindle and this is correct by holding one end of the spindle and turning the other end in the required direction.
5. Fit the starting device pistons in the carburetter body tapered ends first, followed by the coil springs and combined spring guide/retainers, the latter being held in position by circlips.
6. Secure the starting device cover to the carburetter, dowels being provided on the cover for locating purposes, and retain with two screws, flat washers and spring washers, tightening them evenly to avoid distorting the cover; by looking through and spring guide/retainers and operating the lever a check can be made to ensure that the pistons are raised by the operating lever and lowered by the springs when the lever is released.
7. Fit the progression hole inspection plugs, one in each barrel.
8. Fit the starting jets, two per carburetter.
9. Replace the accelerator pump jets (two per carburetter), noting that the smaller diameter enters first and the flat on the large diameter is to the engine side of the carburetter. Check the condition of the retaining screw rubber seals, and the alloy seating washers, and fit these items with the retaining screws.
10. Refit the accelerator pump delivery valves (two per carburetter) by fitting a ball first, then a weight, concave face to the ball, and finally the retaining screws.
11. Fit the emulsion tube holders. Push a hexagonal head main jet into the large diameter end of an emulsion tube and a circular-headed air corrector jet in the other end. Fit the emulsion tube holder over the air-corrector end, and screw the assembly into position.
12. Replace the idling jets (two per carburetter) in their holders and fit them in the carburetter.

13. Check that the accelerator pump inlet valve ball moves freely and screw the valve into the base of the float chamber.
14. Assemble and fit the accelerator pump. Slide the split retainer on the accelerator pump control rod, with the dishing toward the hook end of the control rod, compress the spring and then locate the piston on the control rod. Position the assembly in the carburettor and press the split retainer into position. Check the operation of the pump by actuating the throttles.
15. Screw the needle valve seat into the cover, after ensuring that the seat sealing washer fitted between the seat and cover is in good condition. This sealing washer also affects the float level.
16. Refit the needle valve and floats. Check the needle valve damping ball for free operation and then place the needle valve in its seat. Place a new gasket on the cover and then push the float fulcrum pin through the cover 'legs' and float hinge.
17. Check the float level. Hold the carburettor cover in the vertical position with the floats hanging down and with the tab which abuts the needle valve in light contact with the ball and perpendicular. The distance between both floats and the cover, including gasket, should be 8.5 mm. If necessary, bend the the needle valve tab to obtain this measurement.

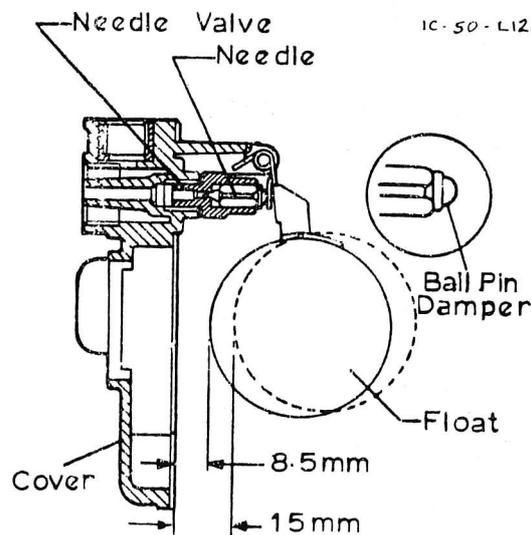

Fig. 12. LEVELLING THE FLOAT  
(WEBER)

After levelling the floats check that the stroke is 6.5 mm., i.e. 15 mm. from the cover. If necessary adjust the position of the other tab, which abuts the needle valve seat, to obtain this movement.

Check also that where the support arms are soldered to the floats, a small tag has NOT BEEN LEFT ON. If evident, this tag must be removed by careful filing, taking care not to puncture the floats or bend the support arms. If the tag is not removed, it could impede high fuel flows at the needle valve, thus

causing fuel starvation.

The float level and stroke should be checked whenever the floats, needle valve, needle valve seat or sealing washer are renewed.

18. Refit the carburettor cover, ensuring that the floats are free to move in the body. Secure with five screws, flat washers and spring washers, tightening them evenly. Refit the small circular main and idling jet cover retained by a wing nut.
19. Place the gauze fuel filter in the top cover, then the brass seat in the gauze filter and finally screw the retainer, with a sealing washer beneath its head, into the cover.
20. Carefully screw the volume control screws (two per carburettor) into position until each just contacts its seat and then unscrew one turn.
21. Fit the throttle stop screw, if fitted, until it just contacts the throttle stop lever and then screw in a further half turn.
22. Fit the main venturis, smaller external diameter first, so that the brass pin in the larger external diameter slides in the barrel's channel.
23. Replace the auxiliary venturis, larger external diameter first, engaging the venturi spring tongue in the barrel channel.

#### To Replace

1. Assemble the two carburettors by placing the air box backplate on its studs. Prime the securing nuts with LOCQUIC PRIMER 'N'.
2. Place air trumpets in position, then their clamps, spring washers and finally the nuts which should be fitted with LOCTITE 'AV'. Tighten the nuts to the torque loading given in 'TECHNICAL DATA'.

### L.12 - ZENITH STROMBERG CARBURETTORS

#### General Description

These carburettors are developed from the CD (constant depression) carburettors, which operate on the principle of varying the effective area of choke and jet orifice, in accordance with the degree of throttle opening, engine speed and engine load.

#### Operation

The petrol inlet is a parallel tube, which accommodates a flexible fuel pipe, situated to one side of the main body. Fuel passes into the float chamber, via a needle valve, where the flow is controlled by the needle in the valve and twin floats mounted on a common arm.

As the fuel level rises, the float lifts and by means of the float arm and tag closes the needle onto its seating when the correct level has been attained. When

the engine is running, fuel is drawn from the float chamber, the float descends and more fuel is then admitted through the needle valve. In this manner, the correct level is automatically maintained, the whole of the time the carburetter is in action.

Fuel in the jet orifice is maintained at the same level as that in the float chamber by means of cross drillings in the jet assembly.

Special features of Emission carburetters ensure that they exactly match one another in respect of flow. Clearance around the piston in its vertical bore permits additional air to 'leak' into the mixing chamber and lower the depression. The first special feature therefore is the manufacturing tolerance compensator or leak balancing screw.

A drilling is taken from the atmospherically vented region beneath the diaphragm to meet a further drilling that breaks into the carburetter mixing chamber downstream of the air valve, in order to introduce an 'air leak'. An adjusting screw with conical tip is inserted into the drilling to the mixing chamber. This is capable of either completely blanking off the air bleed or permitting flow adjustment to maximum effective diameter of the air bleed.

When set, the balancing screw, is sealed with a plug which MUST NOT in any circumstances be tampered within service.

It is essential therefore NOT to change the main body, cover or air valve, after the balance screw has been set and sealed.

### Cold Starting

When the choke control of the facia panel is pulled out, it operates a lever at the side of both carburetters; this rotates a disc in the starting device in which a series of holes of different diameters are drilled. In the full rich position, all holes will be in communication with the starter circuit and provide the richest mixture.

Petrol is drawn from the float chamber via a vertical drilling adjacent to the central main feed channels, through the starting device and into the throttle body between the air valve and the throttle plate. Simultaneously, the cam on the starter lever will open the throttle beyond the normal idle position, according to the setting of the fast-idle stop screw to provide a faster idle speed to prevent stalling when the engine is cold. As the choke control on the facia panel is gradually released, few and/or smaller holes will provide the petrol feed from the float chamber, thereby progressively weakening the mixture strength to the point where the choke control is pushed fully home. Mixture strength is then governed by the Factory setting of the main orifice and idle speed determined by

IC-50-L13

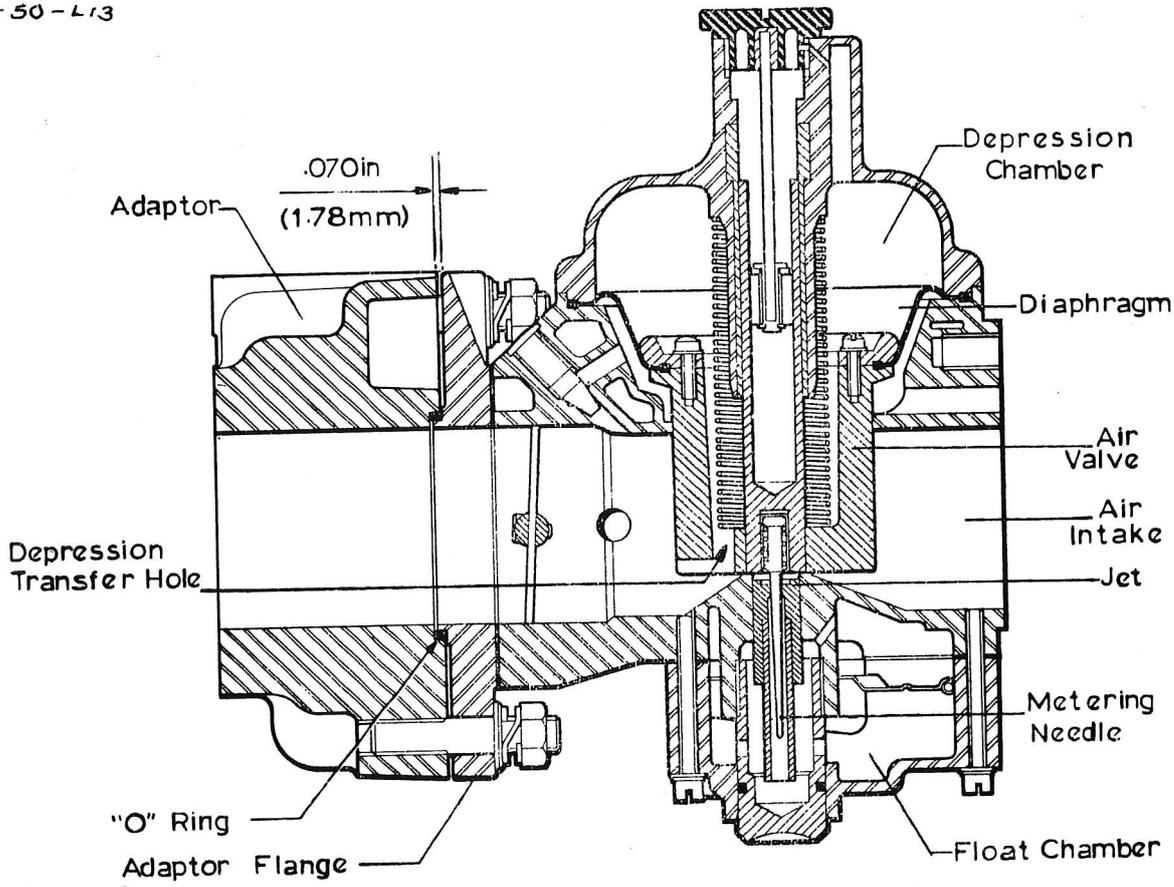

Fig.13. CROSS SECTION - ZENITH-STROMBERG CARBURETTER

IC-50-L14

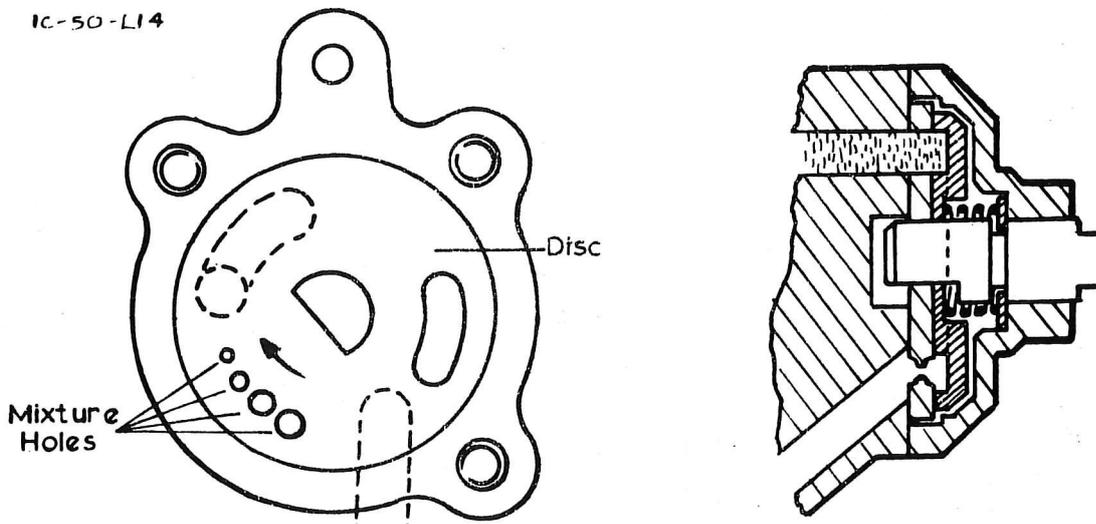

Fig.14. STARTING DEVICE (ZENITH-STROMBERG)

the setting of the throttle stop screw.

NOTE: Do not pump, or hold open the throttles as this reduces the effectiveness of the cold start device (choke).

It is also important to note that there are two positions (winter and summer) on the starting limiting pin. This is the spring-loaded, knurled headed pin located on the side of each starter housing. Push down and turn through 90° by the screw-driver slot provided. In the 'winter' position the slot will be horizontal when viewed from the side of the car, whereas in the 'summer' position the slot will be vertical.

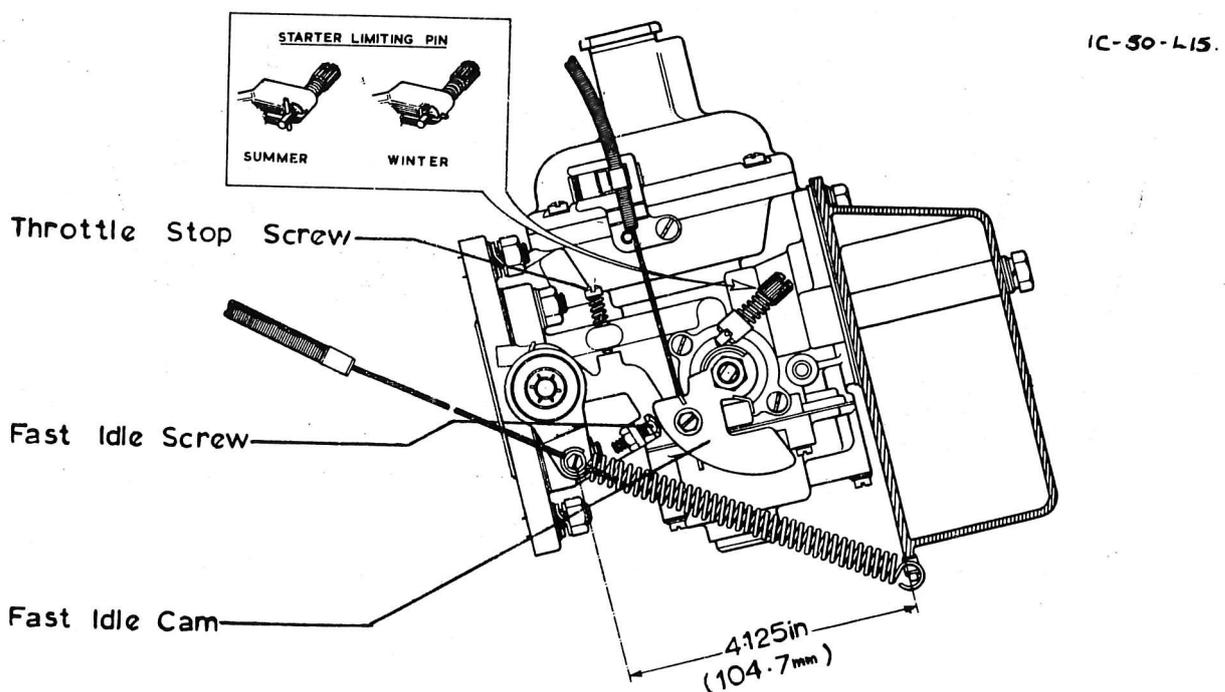

Fig. 15. ADJUSTING SCREWS & THROTTLE LEVER SETTING  
(ZENITH-STROMBERG)

### Idling

Fuel for idling is provided by the jet orifice, the amount being controlled by the jet/needle relationship established during manufacture. Idle speed is regulated by adjustment of the throttle stop screw, which limits the closure of the throttle when the accelerator pedal is released.

An idle trimming screw is provided but THIS IS NOT AN ORDINARY MIXTURE ADJUSTING SCREW. The purpose of this screw is to give a very fine adjustment to compensate for the difference between a new 'stiff' engine and one that is run in. It will be seen that the idle trimming screw regulates a limited amount of air (limited by the side of the drilling) that can be introduced into the mixing chamber.

When the engine is new, a slightly weaker mixture can be used and the trimming screw, will, therefore, be set initially to provide maximum air to the mixing chamber. As the engine loosens during the running-in period, this screw can gradually be turned in a clock-wise direction to reduce the air bleed, until, when fully turned in, the screw will be seated.

It should be noted that to the ear, there may be no detectable difference between fully 'home' and fully 'open' positions, therefore, it should be adjusted to achieve the best driveability.

Should idling quality deteriorate during the running-in period the screw should be rotated clockwise slowly until smooth idling is just restored. If it is not possible to obtain satisfactory quality when the screw is fully home, the manifold to carburettor joints should be checked as a leak is probably occurring. ON NO ACCOUNT SHOULD THE SCREW BE OVER TIGHTENED.

Check also that the choke cable returns the cold start lever to the fully off position when choke control is pushed in. Adjust coupling and cable as necessary.

#### Normal Running

Mention has been made of the jet/needle relationship, which together govern correct idle mixture and mixture strength throughout the range. One feature of the assembly is the radially located needle which is biased so that the needle is permanently in contact with one side of the jet, to ensure a consistent fuel flow from a given needle profile. The jet/needle relationship is set during production and MUST NOT be altered.

When the throttle is opened, air flow under the air valve increases and a temporary rise in mixing chamber depression is transferred via drillings in the air valve to the depression chamber which is sealed from the main body by a diaphragm. Pressure difference between the depression chamber and the under diaphragm chamber causes the air valve to lift. Thus any increase in engine speed or load will enlarge the effective choke area until maximum air valve lift, since the air valve lift is proportional to the weight of air passing beneath it. Therefore, air velocity and pressure drop across the jet orifice remain approximately constant at all speeds.

As the air valve rises it withdraws the tapered metering needle, held in its base from the jet orifice, so that fuel flow is increased proportionate to the greater air flow.

The metering needle is a variable and machined to very close limits. It provides a mixture ratio for all speeds and loads in line with engine requirements that are determined by exhaustive tests on bench and road during original manufacture. To maintain correct results, it is essential that only the recommended needle is used.

Temperature Compensator

Testing has shown the need for a temperature compensator, operating over a wide range of air valve lift, to cater for minor mixture strength variations caused through heat transfer to the carburetter castings.

An air flow channel is employed which permits some of the air passing through the carburetters to by-pass the bridge section. With the introduction of this into the mixing chamber, the air valve, in order to maintain depression on its downstream side rides in a lower position, thus giving a smaller fuel flow annulus. To adjust the quantity of air by-passed, a bimetallic blade is used to regulate the movement of a tapered plug.

Two screws attach the temperature compensator assembly to the carburetter and two seals are provided to ensure that no leakage can occur at the joint with the main body. THIS ASSEMBLY IS PRE-SET AND MUST NOT BE RE-ADJUSTED IN THE FIELD. If it is suspected of malfunction and the tapered plug moves freely when tested carefully by hand with engine both cold and hot, the compensator assembly should be changed for another of the correct specification.

Acceleration

At any point in the throttle range, a temporary enrichment is needed when the throttle is suddenly opened. To provide this, a hydraulic damper is arranged inside the hollow guide rod of the air valve.

The rod itself is filled with suitable oil (see Section 'O') to within a  $\frac{1}{4}$  in. (6.35 mm.) of the end of the rod. When the throttle is suddenly opened, the immediate upward motion of the air valve is resisted by the damper. For this brief period, a temporary increase in the depression over the jet orifice is achieved and the mixture is enriched.

Downward movement of the air valve is assisted by a coil spring.

Flexible Carburetter Mounting

When assembling the adaptor flange/carburetter assembly to the adaptor blocks, the 'O' rings should be located carefully and the nuts should be adjusted to give an even gap of .070 in. (1.78 mm.) between these parts. Care should be taken not to overtighten the nuts as this could distort the adaptor flange.

Check the clearance at every 'A' Service (See Section 'O').

1C-50-L16.

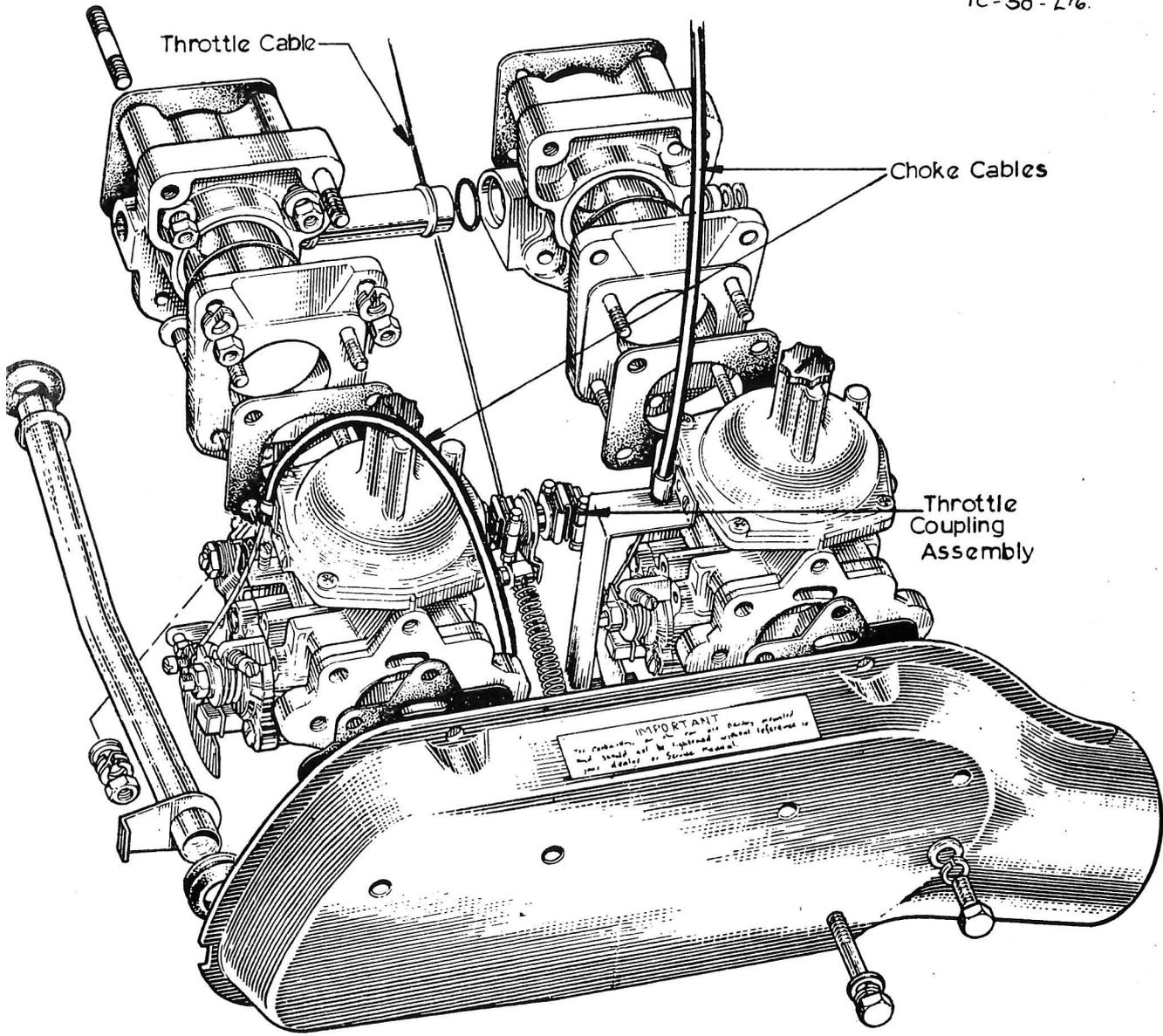

Fig. 16. AIR BOX & CARBURETTOR ASSEMBLY  
(ZENITH-STROMBERG)

L.13 - ZENITH STROMBERG CARBURETTERS

To Remove

1. Release the clip and disconnect the air cleaner trunking from the air box. Remove the bolts securing the air box to the carburetters and remove box together with the two gaskets.
2. Disconnect the throttle and choke cables. Remove the fuel supply pipe at the 'T' piece junction (located between carburetters).
3. Progressively release the carburetters securing nuts (four are visible from above, the other four being below). Remove nuts and washers.
4. Carefully remove the two carburetters as an assembly, ensuring that the synchronising linkage between the two is not distorted. Pull off the gaskets.
5. If it is suspected that an air leak is evident between the adaptor flange and the adaptor blocks, the 'O' ring may be damaged, then the flanges should be removed by releasing their securing nuts. When replacing, always use new 'O' rings and adjust securing nuts as given under "Flexible Carburetter Mounting" (Section 'L.12').

To Replace

1. Using new gaskets (after ensuring no traces of old gaskets remain on mating faces) fit the carburetters as an assembly, tightening their securing nuts progressively to avoid possible distortion of the mounting faces.
2. Reconnect the throttle and choke cables to their respective locations. Replace the fuel supply pipe at the 'T'-piece junction.
3. Using new gaskets, refit the air box. Replace the air trunking between air box and air cleaner.

L.14 - ZENITH STROMBERG CARBURETTERS

To Adjust

The only adjustments that can be made to these carburetters in service are:-

- a. Idle speed. Adjusted by rotation of the throttle stop screw.
- b. Idle mixture. Adjusted over very fine limits by trimming screw for best quality idle and driveability. THIS IS NOT A NORMAL ADJUSTMENT. Variations are very slight indeed.
- c. Synchronisation.

1. Fast Idle

The fast idle screw incorporated in the cold start devices is factory set and should not need attention. Should it be disturbed at any time reset as follows:-

The throttle plate should be held open a fixed amount by laying a drill (size .6 m.m.) in the bottom of the port directly below the spindle. With the started in the full enrichment position the fast idle screw should be adjusted until it touches the fast idle cam. Lock securely with lock nut and remove drill. The carburettors must of course be removed from the engine for this operation.

## 2 Synchronisation

When the carburettors, adaptor flanges and adaptor blocks have been assembled to the cylinder head, leave the clamping screws on the 'W' clips loose until the carburettors have been synchronised and the throttle lever set.

Unscrew the throttle stop screws to permit the throttle in each carburetter to close completely, then screw in the throttle stop screws to the point where the ends of the screws are just touching the levers. From this point rotate the stop screws  $1\frac{1}{2}$  complete turns each, to open the throttles an equal amount and provide a basis from which the final speed of idle can be set.

Ensure fast idle screw is clear of cam, otherwise incorrect synchronisation can result. Check also that the cold start lever is fully off against the stop with the choke control pushed in. Adjust coupling and cable as necessary.

Start engine and warm up to normal temperature.

With air box off check synchronisation by either:-

Tube to ear method: Insert one end of a tube in the choke of the carburetter and note the hiss heard at the other end. Repeat this for the other carburetter and adjust the throttle stop screws until both hisses are of equal volume and the idle speed is 800/900 r.p.m.

NOTE: There is no mixture or volume screw only an idle trimming screw, the function of which has already been described.

Crypton Synchro (or similar) Test: These are proprietary instruments which give a measure of air flow when pressed against the inlet of the carburetter. When doing this take care not to lock the screws until equal airflows are obtained and the idle speed is 800/900 r.p.m.

NOTE: As this system incorporates a balance pipe, carburettors CANNOT be synchronised by shorting out spark plugs and noting the drop in engine speed. Fit the air box, etc. and recheck idle speed.

## 3. Throttle Lever Setting

There is a lost motion built into the throttle lever and coupling spindle assembly to allow the throttle spindle to turn when the cold start and hence the fast idle is operated without pulling the throttle cable return spring.

4. Float Height

When correctly set and with the carburetter inverted, measure to the highest point of the floats above the face of the main body with the fuel inlet needle on its seating. The correct measurement is 16/17 mm. Great care must be taken not to twist or distort the float arms, this to ensure a constant fuel level.

Should it be necessary to reset the float height, this can be carried out by bending the tag which contacts the end of the needle. Care should be taken to maintain the tag at right angles to the needle in the closed position.

NOTES

Idle quality and low speed running depend to a large extent upon the general condition and it is, therefore, essential to check cam followers adjustment, spark plugs and ignition timing if idling is unstable. It is also important to eliminate any leaks at manifold joints.

L.15 - ZENITH STROMBERG CARBURETTERS

To Clean

1. Remove the carburetters from the engine 'Section L.13') to a clean bench.
2. Yellow Service Every 12,000 Miles (20,000 km.)  
For this service, one Yellow Pack 'A' is required for each carburetter. This pack contains 1 floatchamber gasket, 1 'O' ring for floatchamber plug, 1 needle valve washer and 1 manifold/carburetter gasket.
3. First, remove carburetters from induction manifold, then place carburetters on a clean bench to keep the instruments and parts free from contamination and disconnect one carburetter from the other.
4. Have a receptacle available into which fuel from each floatchamber may be drained, then unscrew brass centre plug to carry out this operation.
5. Unscrew the floatchamber fixing screws, taking care not to lose the washers and withdraw floatchamber vertically away from body to clear the float mechanism. Take off floatchamber gasket. Unclip float pivot pin and noting carefully the top in order to ensure correct re-assembly take out floats. Unscrew hexagon bodied needle valve from carburetter body.
6. Take off 'O' ring from centre plug then thoroughly cleanse all parts that have so far been removed.
7. Refit needle valve into floatchamber cover with new washer (thickness 1.6 mm.) and make sure it is screwed tightly into position.
8. Replace float assembly, after inspecting for damage or distortion, slide in

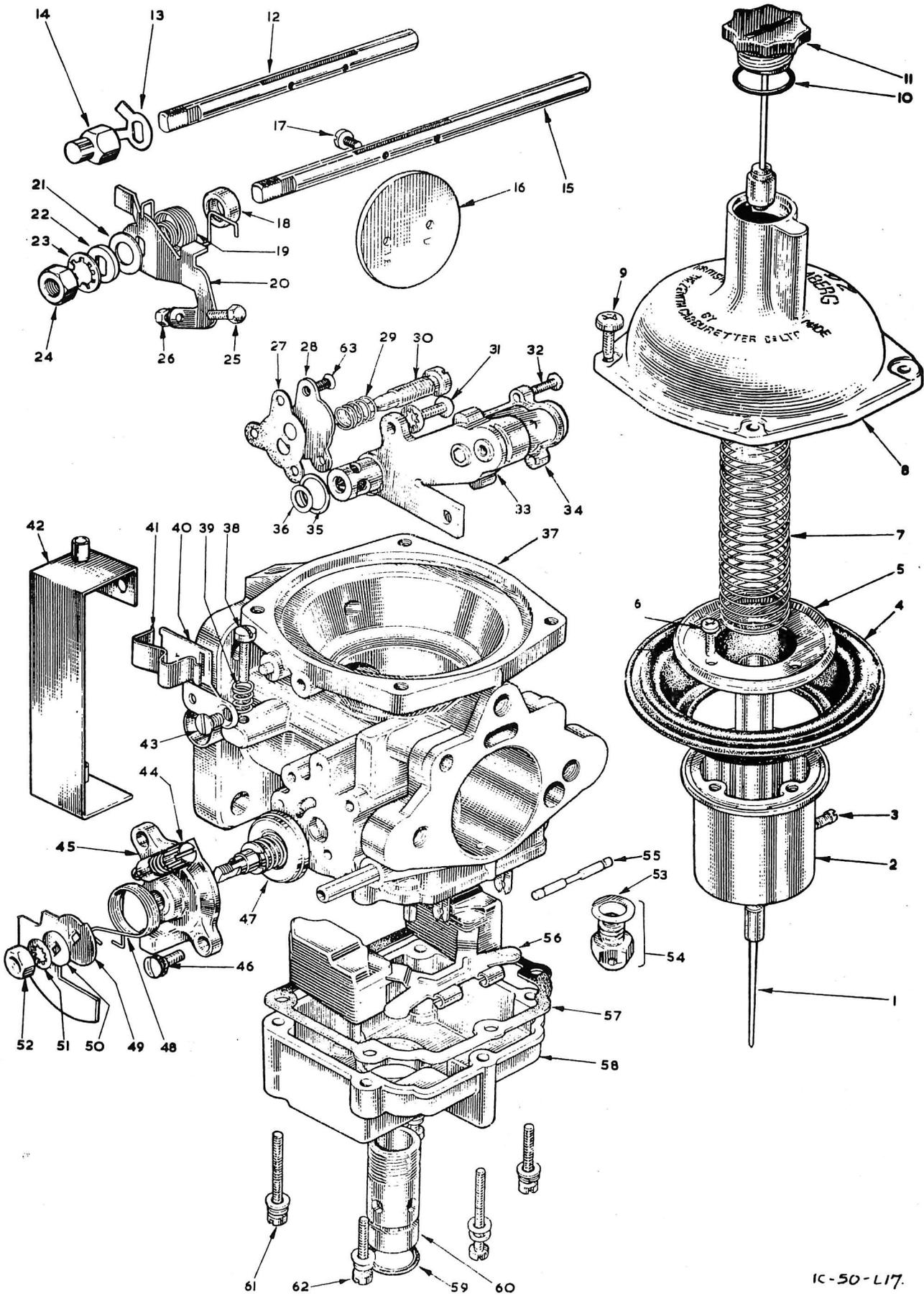

1C-50-L17.

Fig. 17 ZENITH-STROMBERG CARBURETTOR COMPONENTS

Key to Fig.17.

- |                       |                          |                        |
|-----------------------|--------------------------|------------------------|
| 1. Needle.            | 22. Spacer.              | 43. Screw, brackets.   |
| 2. Air valve.         | 23. Lockwasher.          | 44. Limiting pin assy. |
| 3. Screw, locking.    | 24. Nut.                 | 45. Housing, starter.  |
| 4. Diaphragm.         | 25. Screw.               | 46. Screw and washer.  |
| 5. Retaining ring.    | 26. Nut.                 | 47. Starter disc.      |
| 6. Screw.             | 27. Gasket.              | 48. Spring.            |
| 7. Spring, air valve. | 28. Plate, sealing.      | 49. Cam.               |
| 8. Cover, top.        | 29. Spring.              | 50. Washer.            |
| 9. Screw and washer.  | 30. Screw.               | 51. Washer.            |
| 10. Seal.             | 31. Screw.               | 52. Nut.               |
| 11. Damper.           | 32. Screw.               | 53. Gasket.            |
| 12. Spindle, front.   | 33. Body.                | 54. Needle valve.      |
| 13. Tabwasher.        | 34. Cover.               | 55. Pin.               |
| 14. Nut, sleeve.      | 35. Gasket.              | 56. Floats.            |
| 15. Spindle, rear.    | 36. Gasket.              | 57. Gasket.            |
| 16. Throttle.         | 37. Body.                | 58. Floatchamber.      |
| 17. Screw.            | 38. Screw.               | 59. 'O' ring.          |
| 18. Seal.             | 39. Spring.              | 60. Plug.              |
| 19. Spring.           | 40. Bracket. rear carb:  | 61. Screw.             |
| 20. Lever, throttle.  | 41. Clip.                | 62. Screw.             |
| 21. Washer.           | 42. Bracket, front carb: | 63. Screw.             |

- pivot pin and clip assembly into position (see Float Height in Section 'L.14').
9. With the new gasket in position, refit float chamber and tighten the retaining screws securely from centre, outwards. Fit new 'O' ring to centre plug and replace tightly in position. Refit carburettors to adaptor flange with new gaskets supplied.
  10. Top up damper reservoirs with the recommended oil (see Section 'O') to within  $\frac{1}{4}$  in (6.35 mm.) of top of centre rod.
  11. Refit carburettors and reset controls as described in Section 'L.14'.

### L.16 - ZENITH STROMBERG CARBURETTORS

#### Overhaul

1. Remove the carburettors from the engine (Section 'L.13') to a clean bench.
2. Red Service Every 24,000 Miles (40,000 km.)  
This a more comprehensive service for which one Red Pack 'B' is required for each carburettor. This pack contains 1 float chamber gasket, 1 'O' ring, 1 needle valve, 1 diaphragm, 2 throttle spindle seals, 2 temperature compensator seals, 1 flange gasket.
3. Remove carburettors from induction manifold, check carburettor induction flanges for flatness and face-up if necessary. Carry out similar procedure to that outlined for the 12,000 miles service in respect of float chamber cleanliness and float setting. In this instance, however, fit the new needle valve assembly with new washer.
4. Unscrew damper assembly from centre of cover. Unscrew the four cover fixing screws and carefully lift off cover. Remove air valve return spring then take out air valve and diaphragm assembly. Avoid possibility of corrosion to shaft from perspiration of hands by lifting upwards with the diaphragm.
5. Drain oil from damper reservoir (centre of guide rod). Slacken metering needle clamping screw and withdraw metering needle from air valve. Place this carefully to one side to avoid damage.
6. To fit the new diaphragm undo the four screws holding the diaphragm retaining ring onto valve, making sure that the locating tag is recessed into the aperture provided. Drop in retaining ring and replace the four fixing screws tightly.
7. Take metering needle and check spring action in the housing at the top of the shank. Fit metering needle into base of air valve, lining up the flat portion with the locking screw. Using a straight edged strip placed lightly against the small shoulder on the needle, press the assembly into the air valve until the strip aligns the shoulder with the flat surface of the air valve. The locking screw should then be lightly tightened taking care not to collapse the needle

housing. Shoulder alignment is extremely critical and this operation should be accurately carried out. Correctly fitted, the needle will be biased toward the throttle and the shoulder of the needle will be exactly flush with the air valve face.

To check that the correct needle is fitted, hold the housing and CAREFULLY pull out the needle. The needle part number can then be seen on its shank.

8. Carefully enter air valve and diaphragm assembly into main body, guiding the metering needle into the jet with a finger in the air intake. Locate the outer tag of diaphragm in aperture of top of body.
9. To check assembly, look down centre of air valves to see that the two depression transfer holes are parallel to the throttle spindle and that the metering needle is also biased towards the throttle.
10. Replace air valve return spring.
11. When refitting the cover, hold the air valve with finger or thumb in air intake and slide on cover, locating the screw holes. This method will avoid air intake. Tighten the four cover screws evenly then check movement of air valve. Freedom of movement over the full travel is essential and when released from uppermost position, the air valve should fall with a sharp metallic click onto the carburetter bridge.
12. Top up damper reservoirs with the recommended oil (see Section 'O') to within  $\frac{1}{4}$ in. (6.35 mm.) of top of centre rod.
13. Undo the two screws which retain the temperature compensator unit to the main body of the carburetter and withdraw the assembly. Take out the inner seal from carburetter body and remove outer seal from the valve. Change both

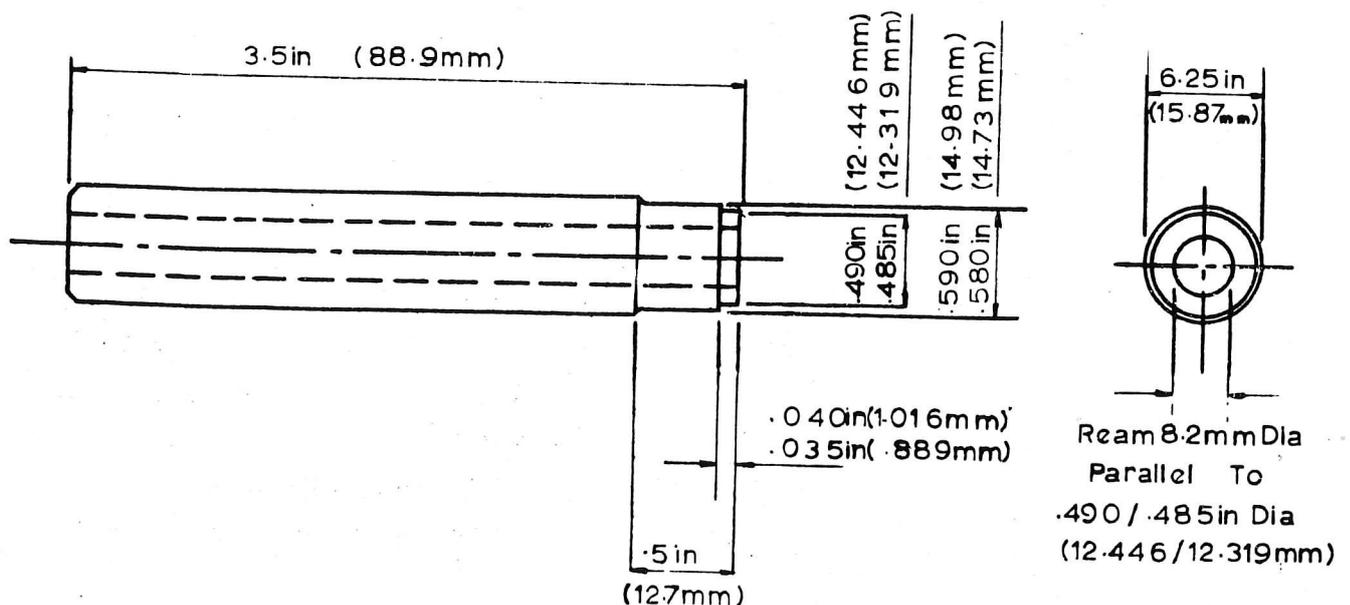

Fig. 18 LOTUS TOOL T. 339

- seals and refit the assembly to the carburetter tightening the two retaining screws evenly.
14. Take off the compensator cover by removing the securing screws and check for free movement of the valve by lifting off its seat. On releasing, the valve should return freely. Do not strain the bi-metal blade or attempt to alter the adjustment. Provided the valve is free, replace cover and fit screws.
  15. To replace the throttle spindle seals, first take off any levers fitted to the spindle ends then carefully prise out the old seals noting how they are fitted. Slide new seals along spindle and press into body recess using Lotus Tool T.339.
  16. Refit carburetters and reset controls as described in Section 'L.14'.

### SPECIAL PARTS

Although already covered, it is thought worthwhile to repeat the items which must not be changed or adjusted in Service.

#### Items That Must Not be Changed

- (a) The jet assembly.
- (b) The air valve.
- (c) The depression chamber cover.

#### Items That Must not be Adjusted

- (d) The position of the metering needle.
- (e) The temperature compensator.
- (f) The air valve return spring loading.

If any of the above items require changing or adjusting with the exception of (f) the sub-assemblies or the complete carburetter must be returned for re-setting. In the case of (d), it is permissible to replace the metering needle provided that the procedure given is followed absolutely, and the correct type ONLY is used.

#### Air Valve/Diaphragm Assembly

A bead and locating tab is moulded to both the inner and outer radii of the diaphragm to ensure correct positioning of this item. The diaphragm is secured to the air valve by a ring and screws with lockwashers and it is necessary to ensure the bead is correctly located and the screws fully tightened.

Location for the bead and tab on the outer radii of the diaphragm is provided by a location channel at the top of the main body. It is important that location beads and tabs are accurately positioned.

When refitting the suction chamber cover, place it accurately so that the screw holes line up with those in the main body, as this will prevent any disturbance of the located diaphragm.

Air Valve Rod and Guide

The air valve rod and guide must be kept clean and should not be handled unduly if corrosion is to be avoided. A few drops of oil (see 'DATA') should be applied to the rod before fitting.

Floatchamber Removal

To prevent the leakage of petrol from the floatchamber, a rubber 'O' ring is situated between the jet cover and the floatchamber spigot boss.

Care should be taken when removing the floatchamber to avoid damage to the faces and floats.

REMEMBER - A CARBURETTER IS AN ACCURATE AND DELICATE INSTRUMENT.  
IT WILL ONLY GIVE OF ITS BEST IF TREATED AS SUCH.

IC - 50 - L19.

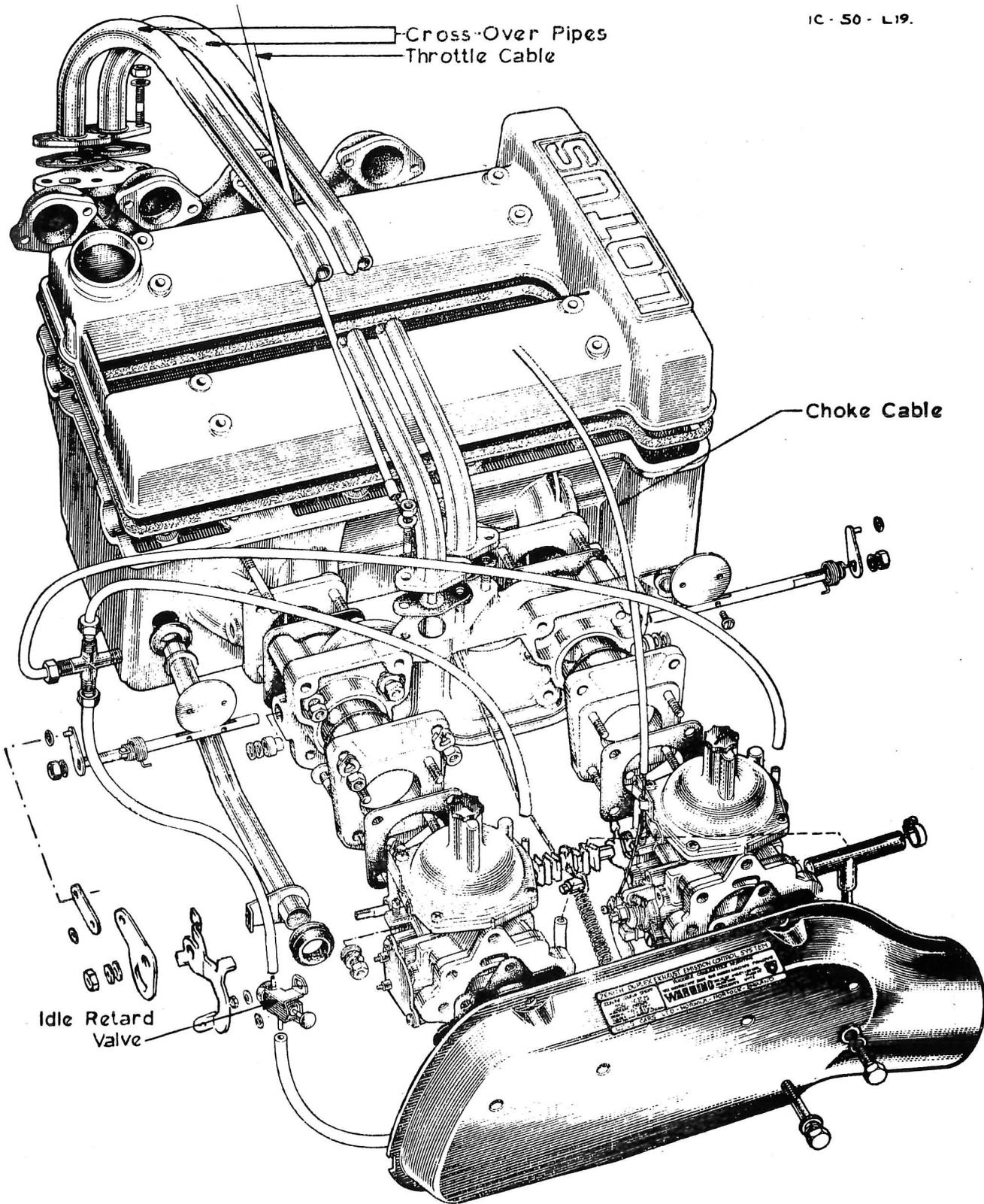

Fig. 19. EXHAUST EMISSION SYSTEM  
(ZENITH-STROMBERG)

L.17 - ZENITH STROMBERG CARBURETTORS (Exhaust Emission)

Description

The main difference between carburetors used in the above application and those described in Sections 'L.12' to L.16' inclusive, is the induction system.

Induction System

This system, by supplying dry mixture to the cylinders, avoids the deposition of wet fuel in the induction manifold that is the prime cause of excessive carbon monoxide and hydrocarbon emissions. To achieve dry mixture the induction manifold requires a heated conditioning chamber. Zenith Duplex employs a main and subsidiary gallery from carburetor to engine. The latter branched from the main gallery, adjacent to the carburetor, conducting the mixture through an exhaust heated conditioning chamber and back into the main gallery. The subsidiary gallery is of smaller cross-sectional area than the main gallery.



IC-50-L20.

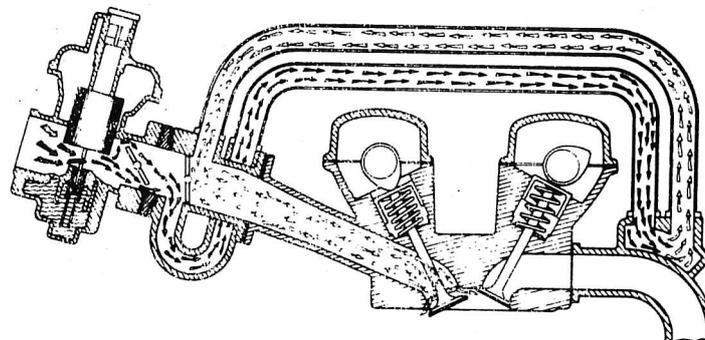

Fig. 20. EXHAUST EMISSION INDUCTION SYSTEM  
(ZENITH-STROMBERG)

Two throttles are therefore employed, primary and secondary, the primary controlling mixture supplied via the subsidiary gallery. The flow capacity of the primary system is sufficient for idling, acceleration up to approximately 50 m.p.h. (80 k.p.h.), over-run and cruising conditions. At the operating point where the primary system begins to impose a significant flow restriction to the engine, a mechanical linkage picks up the secondary throttle and mixture is then supplied through the main gallery. In this manner the primary system is by-passed and flow conditions similar to an untreated engine are restored.

As well as the modified induction system a special distributor is necessary. This is equipped with a vacuum retard capsule arranged to operate only where the throttles are closed; that is on idle and over-run. This is actuated by a valve attached to the rear carburetor which when depressed by the throttle lever connects

1C - 50 - L20

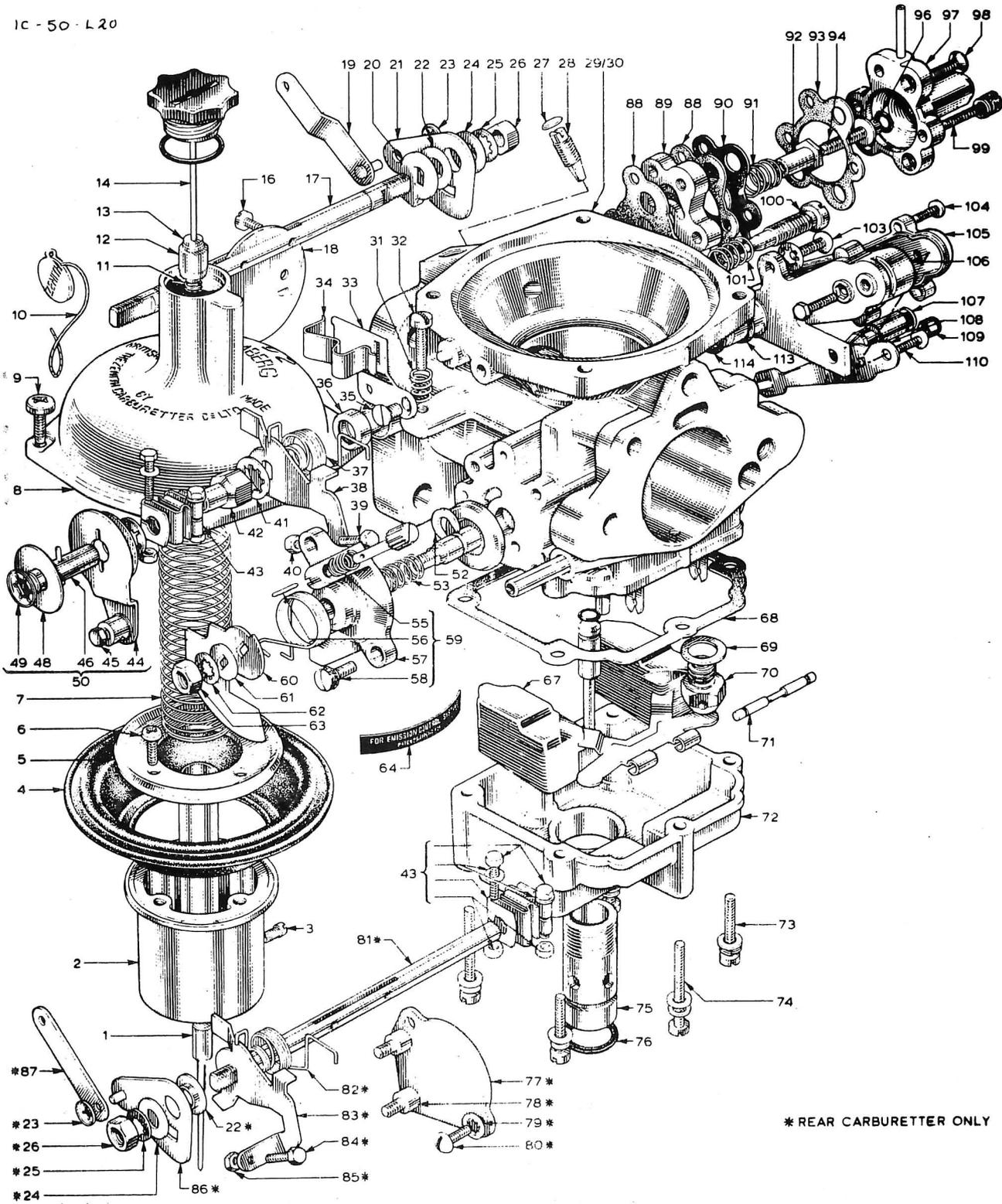

Fig. 21. ZENITH-STROMBERG EXHAUST EMISSION CARBURETTER

Key to Fig. 21.

- |                              |                          |                               |
|------------------------------|--------------------------|-------------------------------|
| 1. Needle.                   | 37. Spring.              | 77. Mounting plate.           |
| 2. Air valve.                | 38. Throttle stop lever. | 78. Stud.                     |
| 3. Locking screw.            | 39. Fast idle screw.     | 79. Lockwasher.               |
| 4. Diaphragm.                | 40. Locknut.             | 80. Screw.                    |
| 5. Retaining ring.           | 41. Lockwasher.          | 81. Spindle, rear throttle.   |
| 6. Screw.                    | 42. Sleeve nut.          | 82. Spring.                   |
| 7. Air valve spring.         | 43. Coupling.            | 83. Throttle stop lever.      |
| 8. Top cover.                | 44. Plate.               | 84. Fast idle screw.          |
| 9. Top cover screw.          | 45. Screw.               | 85. Locknut.                  |
| 10. Seal.                    | 46. Sleeve.              | 86. Lever mounting plate.     |
| 11. Retaining ring.          | 48. Spacing washer.      | 87. Throttle lever.           |
| 12. Bushing.                 | 49. Lockwasher.          | 88. Gasket.                   |
| 13. Washer.                  | 50. Sleeve and plate.    | 89. Valve body.               |
| 14. Damper.                  | 52. Clip.                | 90. Diaphragm.                |
| 16. Throttle screw.          | 53. Spring.              | 91. Spring.                   |
| 17. Spindle, front throttle. | 55. Spring.              | 92. Sleeve nut.               |
| 18. Throttle.                | 56. Pin.                 | 93. Gasket.                   |
| 19. Lever, throttle.         | 57. Housing, starter.    | 94. Retaining screw.          |
| 20. Tabwasher.               | 58. Housing screw.       | 96. 'O' ring.                 |
| 21. Plate.                   | 59. Housing assy.        | 97. Throttle by-pass valve.   |
| 22. Spacer.                  | 60. Starter cam.         | 98. Retaining screw.          |
| 23. Lockwasher.              | 61. Spacer.              | 99. Retaining screw.          |
| 24. Washer.                  | 62. Lockwasher.          | 100. Adjusting screw.         |
| 25. Lockwasher.              | 63. Nut.                 | 101. Spring, adjusting screw. |
| 26. Nut.                     | 64. Label.               | 103. Screw, body.             |
| 27. Plug.                    | 67. Float and arm.       | 104. Screw, cover.            |
| 28. Screw.                   | 68. Gasket.              | 105. Cover.                   |
| 29. Body, front carburetter. | 69. Gasket.              | 106. Body.                    |
| 30. Body, rear carburetter.  | 70. Needle seating.      | 107. Valve.                   |
| 31. Spring.                  | 71. Fulcrum pin.         | 108. Bi-metal strip.          |
| 32. Throttle stop screw.     | 72. Float chamber.       | 109. Nut.                     |
| 33. Plate.                   | 73. Screw.               | 110. Screw.                   |
| 34. Clip.                    | 74. Screw.               | 113. Gasket.                  |
| 35. Screw.                   | 75. Screw.               | 114. Gasket.                  |
| 36. Bush.                    | 76. 'O' ring.            |                               |

the distributor to manifold depression.

### Throttle By-pass Valve

In running experimental Emission Test Cycles, which include two over-run modes, it was shown that rates of hydrocarbon and CO emission are extremely high when manifold depression exceeds 22 in. - 23 in. Hg, the precise critical figure varying with different engines. To prevent rise in excess of the critical figure, therefore, a throttle by-pass valve (97 of Fig. 21) is incorporated in CDSE carburetors. This valve is pre-set and provided that it is free from air leaks, should not require attention. It is possible however, that small particles of foreign matter may lodge under the valve seating, causing leakage and consequent high idle speed. In these circumstances, the valve cover should be removed, the valve and seating cleaned and the parts re-assembled.

It is important not to vary mixture ratio when the by-pass valve is in operation and the circuit, shown on the diagram, feeds from the mixing chamber to the downstream side of the primary throttle. (See Fig. 20.)

Manifold depression acting on the valve diaphragm will cause the valve to open when a value is reached that will overcome the coil spring tension.

### Ignition Retard Capsule

As an aid to emission control on idle and over-run and also as an engine brake to partially compensate for the throttle by-pass, an ignition retard capsule is fitted to the distributor. This is operated by the manifold depression through a valve mounted on the rear of the rear carburettor. This valve connects manifold depression to the distributor only when the throttles close. When the throttles open the valve seals the manifold tapping and vents the distributor to atmosphere. Consequently, the depression pipes must be fitted to the correct spigots on this valve. The bottom spigot connects to the distributor retard capsule.

The adjusting screw on the rear carburettor is factory set but should it be disturbed, reset to give approximately 3/32 in. (2.4 mm.) movement on the valve plunger when the throttles are closing and approximately 1/64 in. (.4 mm.) free play on the plunger when the throttles are closed.

All pipe connections must be air tight.

### Servicing

The servicing required for these carburetors is as given in Sections 'L.15' and 'L.16', with the exception of replacing the throttle by-pass valve gasket.

At intervals of every 24,000 miles (40,000 km), replace the throttle by-pass body gasket by removing the 3 valve body securing screws. While the by-pass body is off the carburettor, the primary throttle spindle seals can be replaced. First,

take off the levers fitted to the primary shaft ends, then carefully prise out the old seals. Slide the new seals along the spindle and press into body recess using Tool No. T 339 (see Fig.18).

Replace the by-pass valve body on the carburetter using a new gasket, then fit and tighten the 3 securing screws.

Inspect the secondary spindle seals to ensure that these also are in good condition. If not, renew them as given for the primary spindle seals.

L.18 - AIR CLEANER

The intervals at which the air cleaner will require attention vary in accordance with the operating conditions.

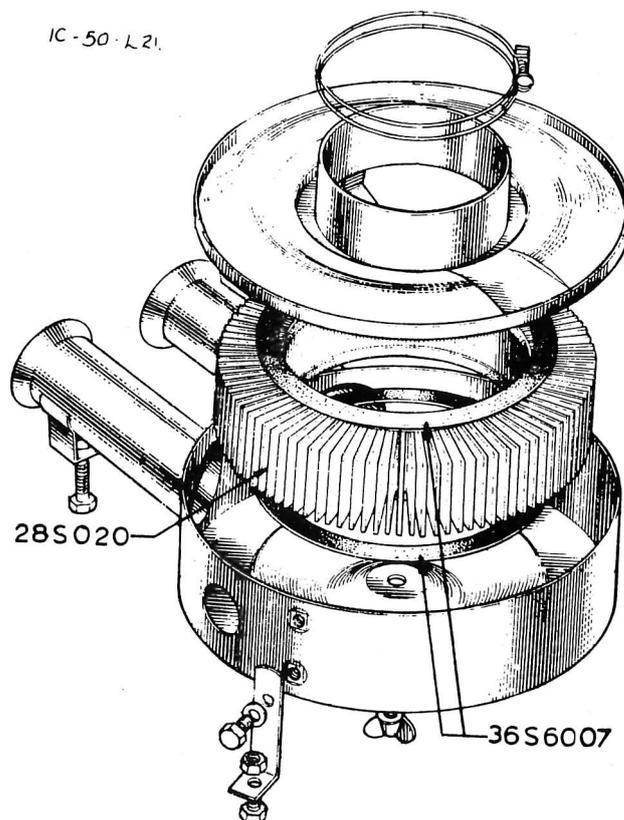

Fig. 22 AIR CLEANER

In towns and areas where the roads are relatively dust free, the intervals given in Section 'O' should be adhered to but, in areas where the atmosphere is smoke or fog-laden, or where the roads are un-metalled, attention will be needed at more frequent intervals.

To Renew Element

1. Remove front grille (see Section 'B').
2. Remove air trunking by releasing the large clip.
3. Release the air cleaner retaining bolts, and remove cleaner from car.

4. Invert the cleaner body and remove wing-nut to dismantle.
5. Clean the inside of the body and top flange of any accumulated dust and dirt.
6. Place a rubber sealing ring (supplied with element) at either side of the element, fit element assembly into cleaner body, fit top flange and replace wing-nut.
7. Replace air cleaner assembly into the car and secure with its retaining bolts. Replace air trunking by secure tightening of its clip and finally, refit front grille.

Water Contamination

If it is found that the element is contaminated by water, it is recommended that the cover be removed and a .75 in. (19.05 mm) diameter hole be drilled in the body cover as near as possible to its periphery, to provide water drainage. On later models the air cleaner is mounted vertically.

L.19 - CHOKE CONTROL

To Remove

1. Disconnect inner cable at the carburetters then pull out from front of facia.
2. The outer casing can be removed by first releasing it at the carburetter clamp, then releasing the locking ring from the front of the facia.

To Replace

1. Replacing both the inner cable and the outer casing is a reversal of the the removal procedure, but noting that the outer casing is not fouling, or being fouled by other equipment behind the facia. Also check that the grommet is fitted correctly where the outer cable passes through the bulkhead.

L.20 - THROTTLE CABLE

To Remove

1. Disconnect inner cable at the carburetters.
2. From the footwell inside the car, press down the throttle pedal to expose its upper end, then pull out cable. Continue pulling to fully free the cable.
3. The outer casing is removed by lifting out of its location.

To Replace

1. Replacing the inner cable can only be done by threading through the body apertures from inside the footwell.

THROTTLE PEDAL

Full instructions for removing the throttle pedal will be found under the heading 'Pedal Box Assembly' in Section 'J' (Braking System).

L.21 - CARBURETTOR FAULT FINDING

The carburetors cannot function correctly if the ignition system, fuel supply, or engine condition are at fault.

Unless known to be in perfect condition the following items should be checked before making any adjustments, or concluding that the carburetors are not operating correctly. If, after making the following checks, the carburetors are proved to be faulty, the possible cause or causes, will be found under the headings 'Erratic or Poor Idling', 'Hesitation or Flat Spot', 'Heavy Consumption'.

Ignition System

1. Check static ignition timing is set correctly by using the timing marks on the crankshaft pulley and on the front cover. The correct setting is given in 'TECHNICAL DATA'.
2. Check sparking plugs. An incorrect grade of plug can cause misfiring at low engine r.p.m., or pre-ignition at high engine r.p.m. The correct grade is given in 'TECHNICAL DATA'. Clean and reset gaps.
3. Check condition and tightness of distributor high and low tension leads. Check condition and setting of contact breaker points, and moving contact point spring tension. Ensure that the advance mechanism is working correctly.

Mechanical

1. Incorrect valve timing. If the engine has just been overhauled, it is possible that the sprockets have not been assembled to their correct shafts. The jackshaft sprocket has no timing mark. The inlet and exhaust sprockets have timing marks which differ by one tooth. The exhaust camshaft sprocket is etched 'EX'; it may be necessary to remove the retaining bolt and washer in order to see this etching. Having verified that the sprockets are fitted in their correct locations, check the valve timing.
2. Ensure that valves are not sticking and check cam follower clearances.
3. Check compression pressures in the following manner. Engine should be hot, all sparking plugs removed, throttles fully open and ignition 'LT' cable removed (to prevent possible fire hazard). Cylinder pressures should be within 20 lbs. sq.in. (1.40 kg. sq.cm.) of each other, and above 160 lbs. sq.in. (11.24 kg. sq. cm.).

Exhaust System

1. Check that the exhaust manifold is not leaking, or that the exhaust system has not become damaged or blocked. An exhaust manifold which is blowing can cause as serious an effect on an engine as a leaking induction manifold. If the leak occurs between the head and the manifold, check the manifold for trueness, clean the joint faces and fit new gaskets. Tighten the manifold to the head BEFORE tightening the nuts and bolts on the rest of the exhaust system.

Fuel System

1. Ensure that an adequate supply of fuel is being delivered to the float chamber.
2. Examine carburetters mounting and adaptor blocks (Zenith Stromberg only) for air leaks.
3. Ensure that the air cleaner is fitted correctly and not restricting the air supply to the carburetters due to the element being dirty.

Erratic or Poor Idling

1. Incorrect fuel level caused by maladjusted floats and/or worn or dirty needle valve. Check float height and wash needle valve in clean methylated spirit or alcohol. Replace needle valve if worn. Check also that floats are not punctured.
2. Throttles not synchronised. Re-set correctly.

Weber: 1. Jets partly blocked. Clean as necessary.

2. After reasonable service, inspect throttle spindle for wear. Replace if necessary.
3. Leakage at induction manifold joints. Remake joints, facing flanges as required. Check that 'O' rings are correctly located.

Zenith Stromberg:

1. Air valve sticking. Check free movement of spring-loaded metering needle, clean air valve rod and guides. Lubricate air valve rod and guide with a few drops of light oil.
2. Metering needle incorrectly fitted. See that shoulder of needle is flush with face of air valve and that the needle is biased towards the throttle. Also, check identification to ensure correct needle fitting. Check that needle housing has not been distorted by over-tightening retaining screw.
3. Partially or fully obstructed diaphragm and float chamber ventilation holes. Check that air box is correctly fitted and that gaskets are not causing obstruction.

4. Diaphragm incorrectly located or damaged. Check location with depression chamber cover removed. The two depression holes at the base of the air valve should be in line with and towards the throttle spindle. Renew diaphragm if damage is evident. When replacing depression chamber cover, the damper ventilation boss must be towards the air intake.
5. Temperature compensator not operating correctly. With engine and carburetters cold, remove cover from temperature compensator assembly. Tapered valve should be seated in this condition. Check operation by carefully lifting the valve off its seat; when released, the valve should return freely. If any damage should have occurred that prevents the mechanical operation functioning correctly, the compensator unit should be changed.
6. After reasonable service, inspect throttle spindle seats and throttle spindle for fracture and wear respectively. Replace if necessary.
7. Leakage at induction manifold joints. Remake joints facing-up flanges as required. Check that 'O' ring, adaptor flange to adaptor block and balance pipe 'O' rings are correctly located.

Hesitation or Flat Spot

Possible causes are as given for 'Erratic or Poor Slow-Running' but with the addition of the following:-

Weber: 1. Fuel Filter partially blocked.

Zenith Stromberg:

1. Damper inoperative. Check oil level and top-up with oil (see Section 'O').
2. Air valve return spring missing or incorrect part fitted.

Heavy Consumption

Here again, any points that have been covered under the two previous headings can contribute to heavy fuel consumption.

Ensure choke cable returns the cold start lever to the fully off position when choke control is pushed in. Adjust coupling and cable as necessary.

Additionally, check that there is not a fuel leak from the floatchamber joints.

ADDITIONAL INFORMATION

L.22. - WEBER CARBURETTERS AIR TRUMPETS

Commencing at Engine No. C 22414, the air trumpets are sealed with 'Hylomar SQ .32M' before being fitted to the carburetters. If it is desired to carry out this

operation to cars already in service, the following procedure is recommended:-

1. Remove the carburetters air trumpets and the airbox backplate.
2. Using 'Hylomar', fill the recess in the carburetter air inlets as shown at 'A' in Fig. 23, and smear 'Hylomar' around the air trumpets as shown at 'B'.
3. Allow 10 minutes to elapse before refitting backplate and air trumpets to carburetters.

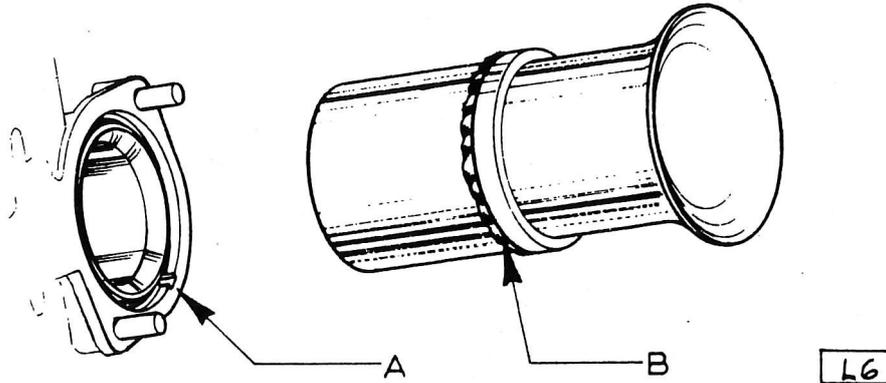

Fig.23. SEALING CARBURETTER AIR TRUMPETS

#### L.23. - AIR CLEANER TRUNKING

Commencing at Chassis No. 7001030077L, a new air trunking (Part No. A050 S 0168) between the air cleaner and the airbox has been fitted. The new trunking which is constructed of bitumen paper/aluminium is less susceptible to splitting and kinking, thus ensuring that all air entering the air cleaner gives a better airflow to the carburetters. It is therefore recommended that all 'S' cars be modified to incorporate this new trunking.

1. Remove the bonnet lid (see Section 'B').
2. Remove the existing air trunking and discard.
3. Re-locate the radiator recuperator bottle (see Section 'K').
4. The fitting of the new trunking will be greatly facilitated if the air cleaner is mounted vertically as in current production. Using the mounting brackets as templates, drill three No. 10 U.N.F. clearance holes after positioning the air cleaner centrally as far forward as possible, without touching the body and with the air intakes pointing rearwards. The air outlet to which the air trunking is attached, should be to the R/H side of the car. Mount the air cleaner using 3 screws (Part No. 026 B 6006), 3 washers (Part No. A03W 1206) and 3 nuts (Part No. YUFN 030F).
5. As the new trunking is less flexible than that discarded it will be necessary to pre-form the bends, following the R/H wall of the engine compartment as far as possible. Fit the trunking to the air cleaner and the airbox, using the original clips to secure it.
6. Replace the bonnet lid.

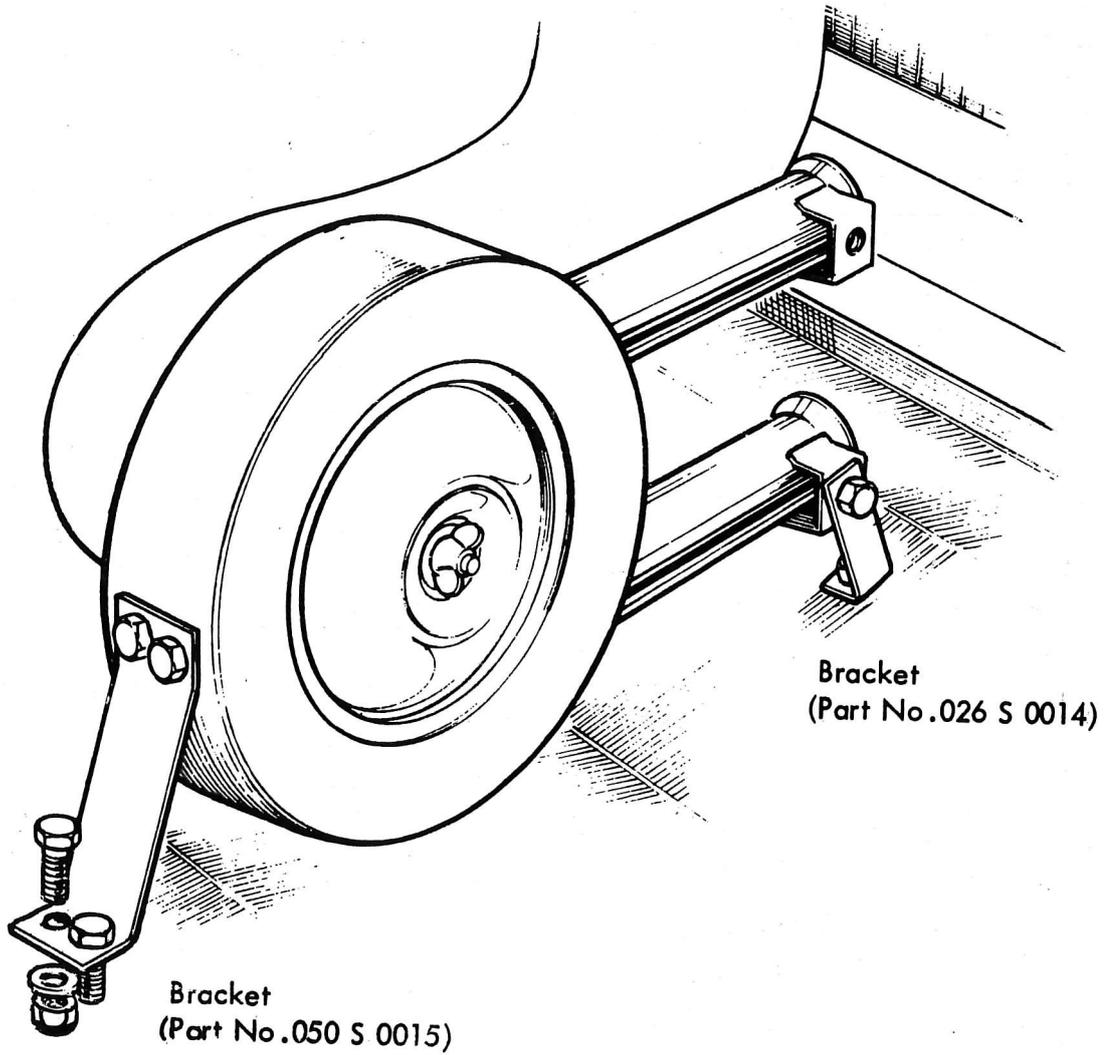

Fig. 24. AIR CLEANER MOUNTING

L.24 - STARTER HOUSING (EXHAUST EMISSION CARBURETTORS)

Where complaints are received of difficult cold starting and all other conditions (ignition timing, sparking plugs, etc.) have been checked and found satisfactory, then the following action is recommended.

1. Release the choke cable and remove the starter housing assembly from the front carburetter.
2. Using the shank of the appropriate drill, check that the progression holes in the starter disc are to the following specification:-
  - 1st. hole = .40 mm.
  - 2nd. hole = .60 mm.
  - 3rd. hole = .80 mm.
  - 4th. hole = 1.00 mm.

If the holes are NOT to this specification, they should be drilled out.

3. a. Remove the starter disc as an assembly from the starter housing assembly by releasing the nut securing the fast idle lever to the housing.
  - b. Remove the circlip and spring holding the halves of the disc together. The outer side of the disc halves is held by the staked end of the shaft.
  - c. Allow the halves of the disc to part, then using the appropriate drill with soft grease in its flutes, rotate the drill between the fingers to enlarge the hole. Care must be taken during this operation that the holes are not elongated.
4. After drilling, replace all parts by reversing the removal procedure.

L.25 - 1971 EVAPORATIVE LOSS CONTROL (EXHAUST EMISSION)

To eliminate fuel vapourization into the atmosphere and thus comply with the 1971 U.S. Federal Motor Vehicle Safety Standards, an 'evaporative circuit' has been incorporated into the fuel system.

The evaporative loss control system consists basically of an activated charcoal canister which collects the fuel vapour given off from the fuel tank vent. Additional to the fuel tank is a catch tank, which cannot be filled through the main tank fuel filler neck. This catch tank prevents neat fuel from reaching the charcoal canister in conditions of extreme heat, or violent vehicle manoeuvres. The absorbed vapour in the charcoal is 'purged' by clean air while the engine is

SECTION L - FUEL SYSTEM

running, via throttle edge drillings (in the carburetter).

The system is effectively maintained by renewing the charcoal canister at intervals of every 48,000 miles (60,000 km.).



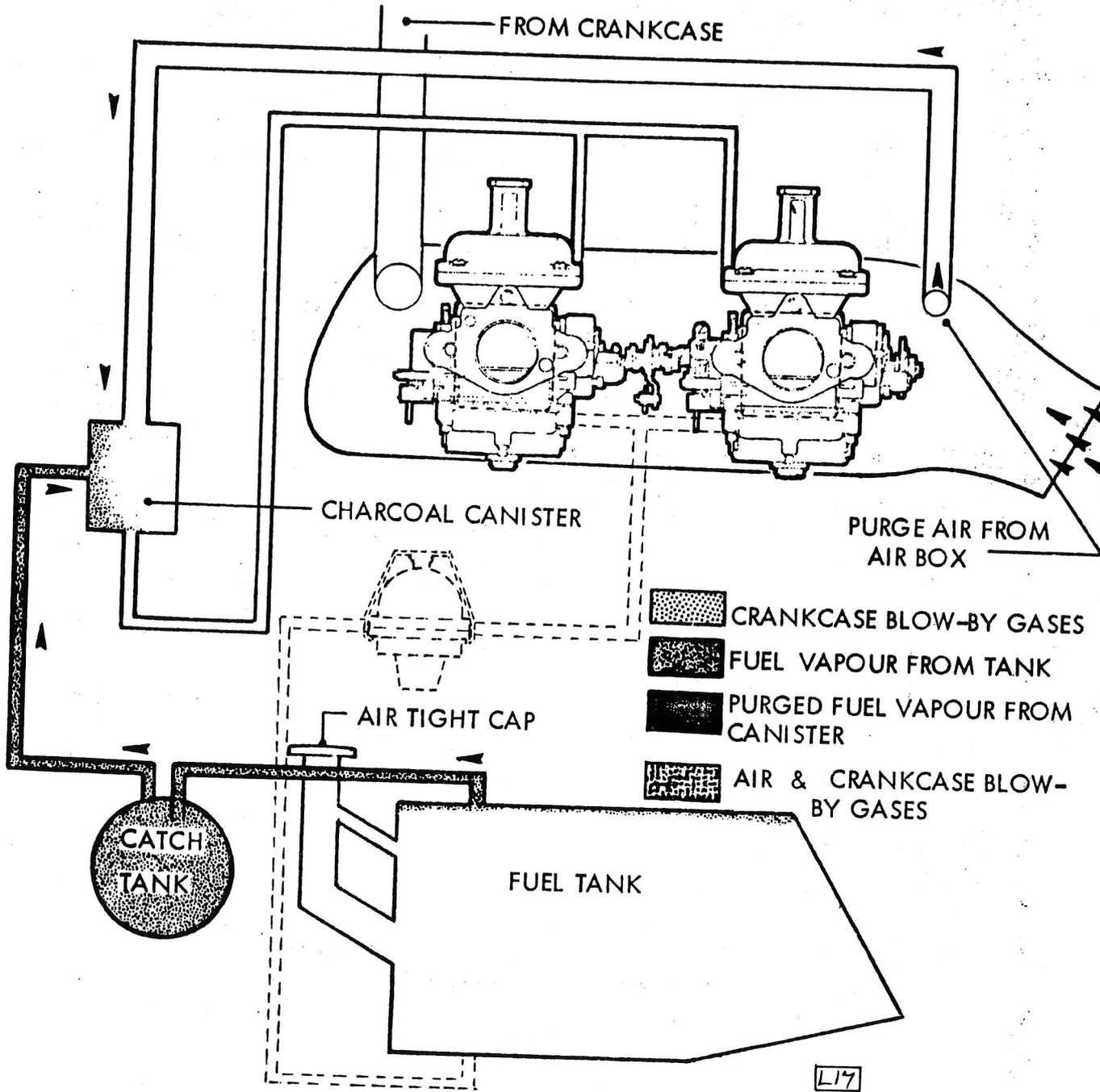

Fig. 26 EVAPORATIVE LOSS CIRCUIT (ENGINE OFF)

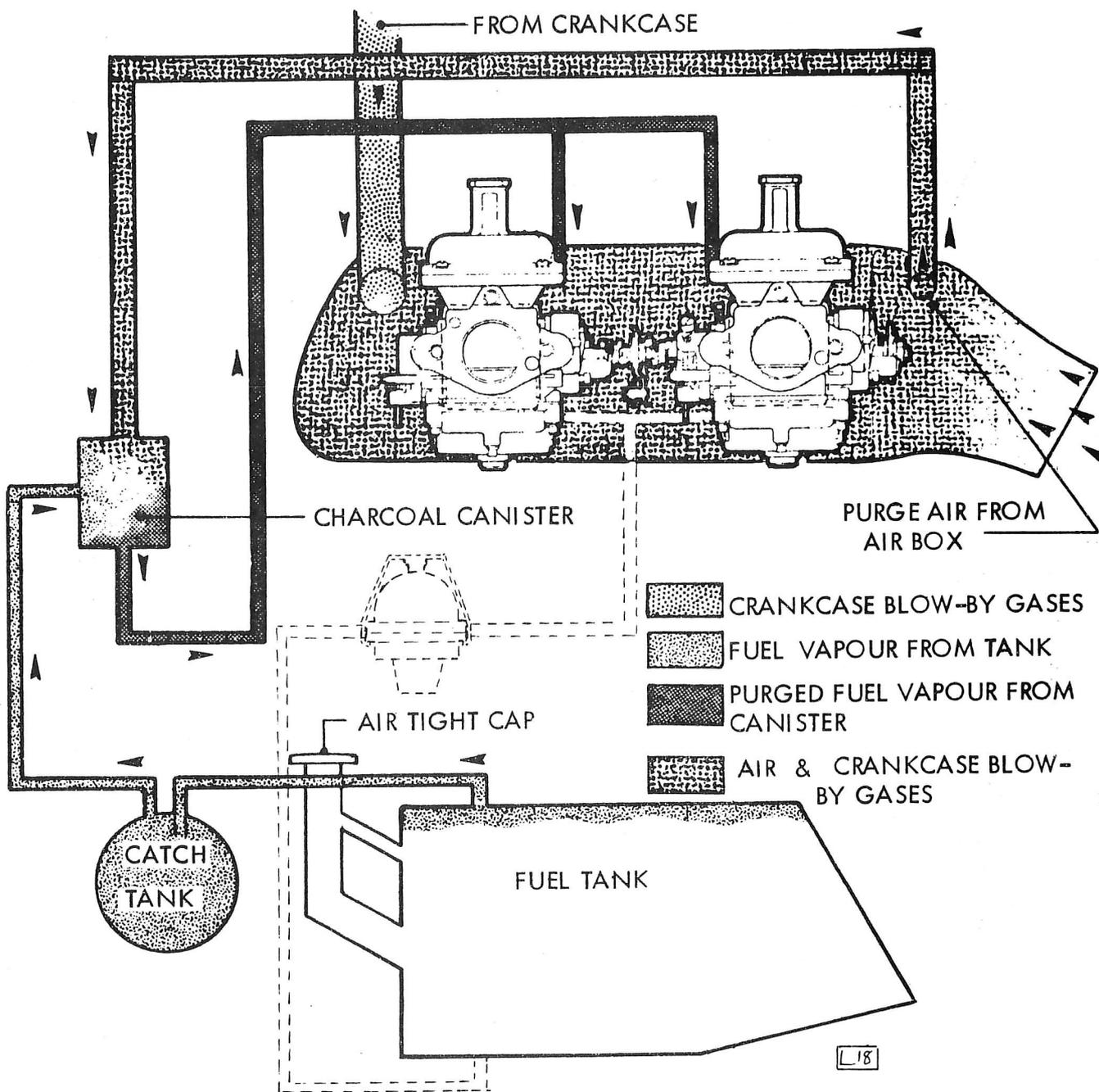

Fig. 27 EVAPORATIVE LOSS CIRCUIT (ENGINE RUNNING)

L.26 - DELLORTO CARBURETTORSDescription

These carburetors are very similar in both operation and physical appearance as Weber carburetors (see Section 'L.7').

Starting (Fig. 28.)

Fuel from the tanks is delivered to the banjo, (2) then through the filter (1) to the float chamber via the needle valve, (15) and its seat, (14). The fuel level is determined by the float, (17). The float chamber is vented to the atmosphere at (4).

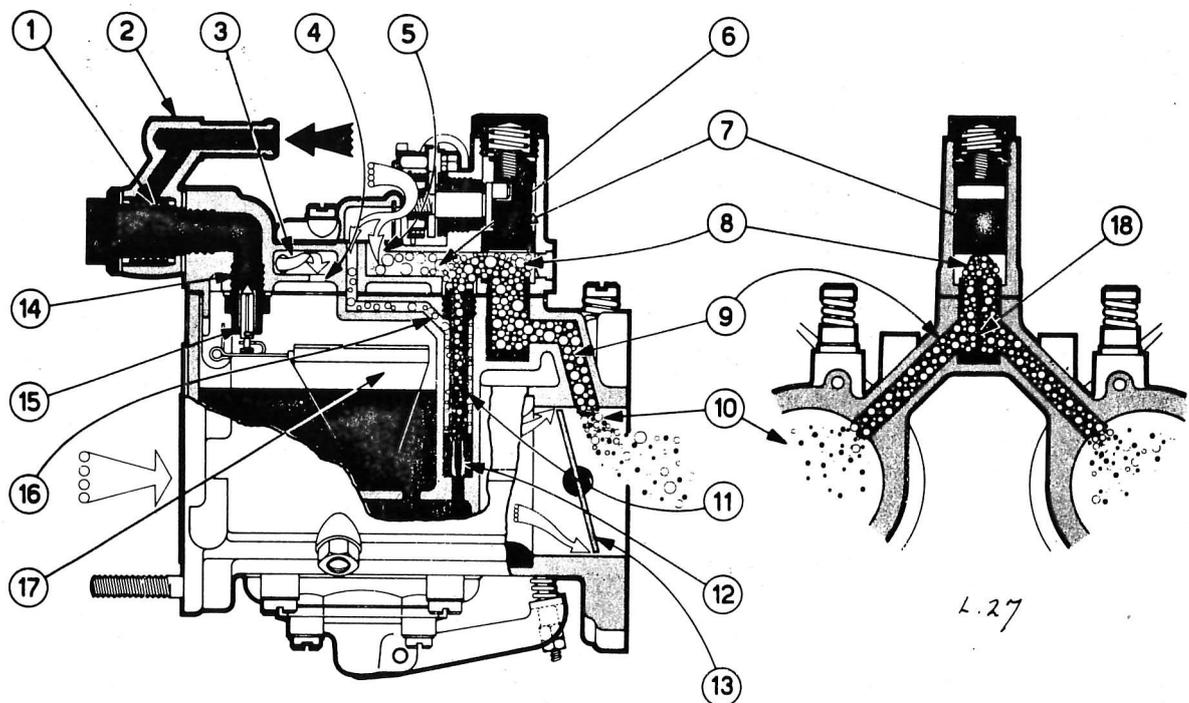

Fig. 28. STARTING CIRCUIT.

When the starter valve (7) is opened, the fuel, set by the jet (12) enters the emulsion tube (11), where it mixes with the air from the channel (16), the mixture passing into the channel (6) mixing further with air from hole (5). Arriving at the valve chamber (8), the mixture spreads into the two channels (9) that flow into the main barrels (10), downstream of the throttle butterfly (3). When the starter valve (7) is closed, the communication between the two main barrels and the starter device is disconnected and by means of the partition (18) the one of the two main barrels (10).

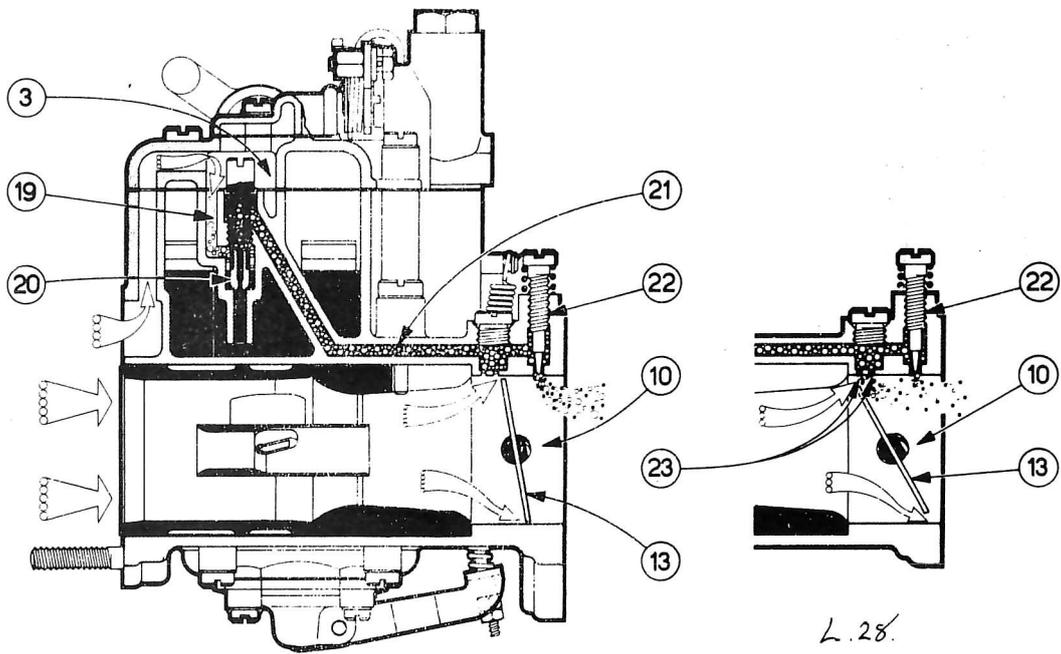

Fig. 29. IDLE & PROGRESSION CIRCUITS.

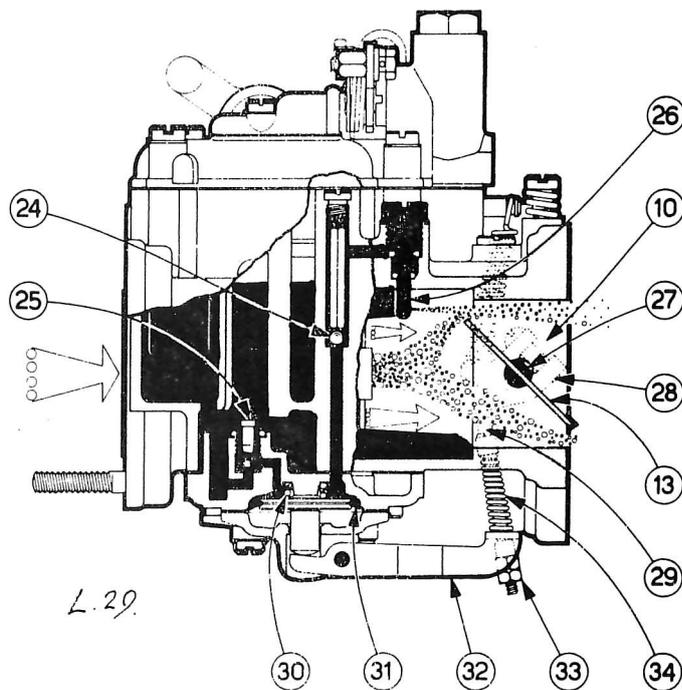

Fig. 30. ACCELERATION CIRCUIT.

Idle (Fig. 29.)

The fuel from the float chamber is set by the idle jet (20). This fuel mixes with the air from the emulsion tube (3) via the channels (19). The mixture then passes through the channels (21), to the adjustment screws (22), then having been metered, to the main barrels (10) down stream of the throttle valves (13).

Progression (Fig. 29)

At the opening of the throttle valves (13) during the passage from idle to main, the mixture arrives at the main barrels (10) via the progression holes (23).

Acceleration (Fig. 30.)

When the throttle valves (13) are opened, the lever (28) attached to linkage (27), pushes a rod (29) and spring (34), this in turn actuating a lever (32) thus operating the diaphragm (31). The diaphragm is held in position by a spring (30).

The diaphragm pumps fuel in two separate circuits through the delivery valves (24) and the pump jets (26), then to the main barrels (10) when the throttle valves are closed, the diaphragm returns to its off position, pushed by the spring (30), sucking fuel from the float chamber via valve (25) during this operation. The nuts (33) are used to adjust the pump capacity.

Main (Fig. 31.)

When the throttle valves (13) are opened, the fuel from the float chamber set by the jets (37), enters the emulsion tubes (36) and mixes with the air set by the calibrating orifice (35). The mixture thus made, enters the channels (39), passes to the auxiliary venturi (38) where further mixing with air from the main intake, the mixture passes to the main barrels (10)

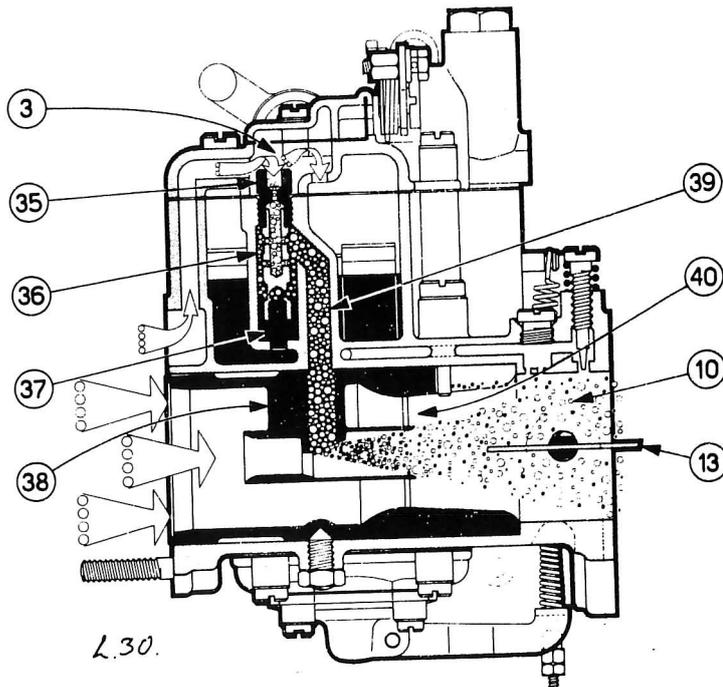

Fig. 31. MAIN CIRCUIT.

Synchronisation (Fig. 32.)

To obtain correct synchronisation of the carburetters, the following procedure is recommended:-

1. Disconnect the accelerator control cable from the lever (1) at the rear carburetter.
2. Release the adjustment screw (2) for the throttle valves making contact with the end of the lever (3).
3. Release the screw (4) in lever (5) to ensure that when pressure is applied to lever (1) on rear carburetter, perfect closure of all throttle valves in both the front and rear carburetters is achieved.
4. Still keeping the same pressure on the lever (1) adjustment screw (4) to hold lever in that position. The throttle valves should all close perfectly.
5. Give ONE FULL TURN to screw (2) so that it is now in contact with the lever (3).
6. Fully close the mixture screws (6), then "BACK OFF" 2 FULL TURNS.
7. Re-connect the accelerator cable to its lever. (1)
8. Start the engine and allow to reach its normal operating temperature. Using the adjustment screw (2), adjust the engine speed to the r.p.m. given in 'TECHNICAL DATA'. If the engine now runs irregularly, adjust the mixture screws (6) on each barrel, to obtain regular running on all barrels. Turning the screws INWARDS

- WEAKENS the mixture, whereas turning the screws OUTWARDS RICHENS the mixture.
9. Using the screw (2), readjust the engine speed.

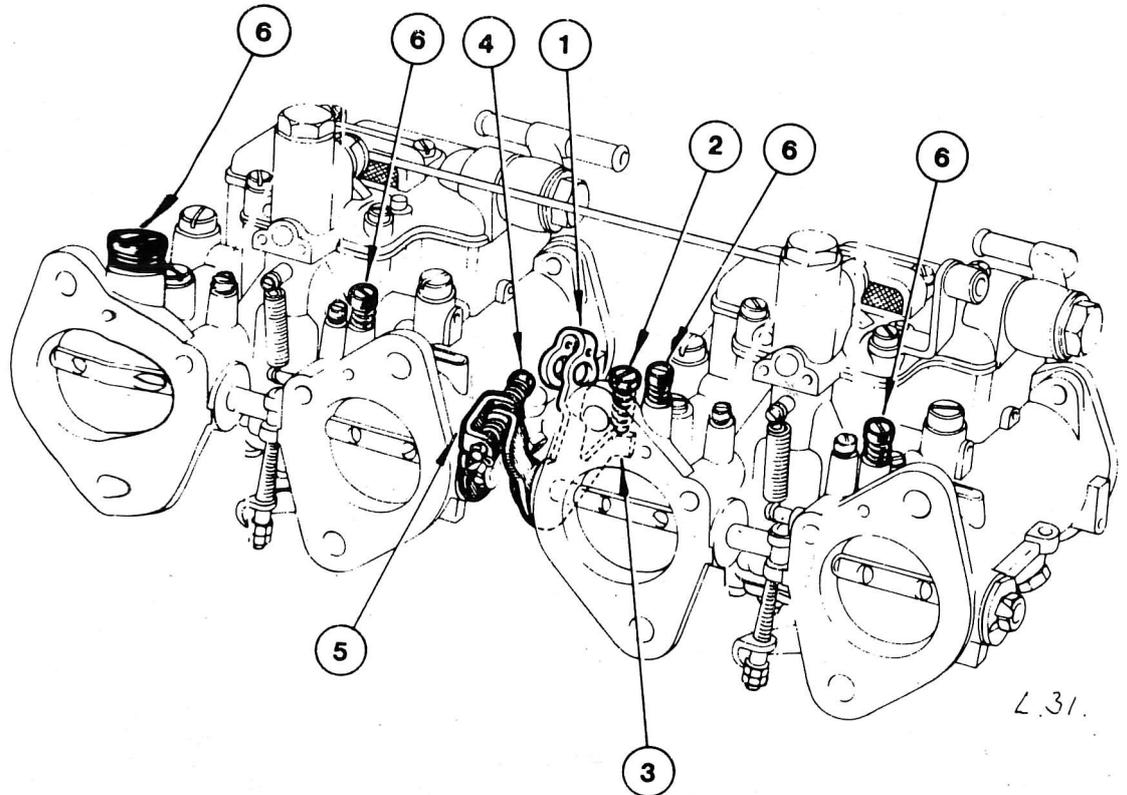

Fig. 32. CARBURETTER SYNCHRONISING SCREWS.

Checking the Float Chamber Level (Fig. 33)

1. Hold the float chamber cover in the vertical position, with the floats hanging down. The tab should be in light contact with the needle.
2. The distance between the floats and cover (Dimension 'A'), including gasket should be:

Type DHLA 40	14.5 - 15.0 mm.
Type DHLA 40E	16.6 - 17.0 mm.

If necessary, bend the needle tab valve to achieve these dimensions.

3. Where 'Type DHLA 40' carburetters are persistently flooding, reset the float chamber level to 16.5 - 17.0 mm., and fit a 'Viton'-tipped needle valve (B036 E 6060 Z).

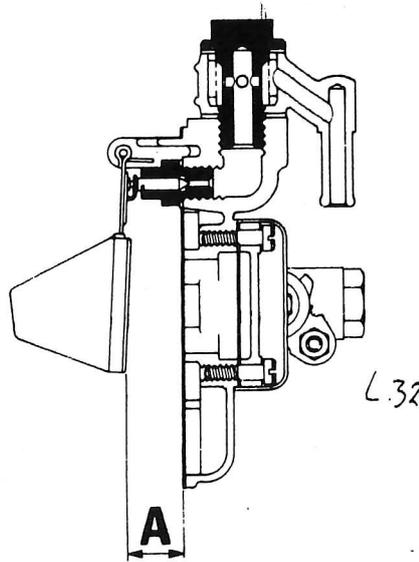

Fig. 33 FLOAT CHAMBER LEVEL.

CARBURETTER FAULT FINDING.

It is assumed that all engine mechanical and/or ignition faults have been corrected, therefore ONLY possible carburetter faults will be listed below.

Fuel Leakage:

Possible Cause.

1. Float needle valve dirty, or worn, or valve seat loose on its thread.
2. Float not free (tight on its hinge, or rubbing on sides), or heavy.
3. Fuel feed pipes loose, or broken.
4. Gaskets hardened, perished or loose.
5. Torn or punctured pump diaphragm.

Suggested Remedy.

- Thoroughly rinse clean filter and valve.
- Fully tighten the valve seat.
- Fit new float assembly.
- Tighten pipes and unions, or replace.
- Fit new gaskets.
- Replace diaphragm.

Cold Start Difficulties.

Possible Cause.

1. Abnormal level of petrol in float chamber.
2. Starting device actuating cable not sliding freely, broken unattached.
3. Strangler valve seized.
4. Starter jet dirty.

Suggested Remedy.

- Check float level.
- Replace the cable.
- Free strangler valve.
- Clean, or replace jet.

Irregular Firing of Engine.

Possible Cause.

1. Incorrect adjustment of mixture screws.
2. Idling jet dirty or loose.
3. Progression holes, or idling circuit ducts blocked.
4. Air leak from mounting flange.
5. Throttle spindle leaking air through its bearings.
6. Throttle valves, or their control, not moving freely.

Suggested Remedy.

- See 'Synchronisation'.  
Clean and tighten.  
Thoroughly clean all orifices and ducts.  
Replace gaskets and fully tighten screws.  
Replace spindle and bearings.  
Free throttle valves and throttle spindle.

Vehicle Not Attaining Maximum Speed, or Lacking Hill Climbing Power.

Possible Cause.

1. Main jet, power jet, emulsion calibrating orifice or emulsion tube, blocked or loose.
2. Throttle valve not fully opening.

Suggested Remedy.

- Check, clean or replace defective parts.  
Check throttle valve and linkage.

Insufficient Acceleration Mainly in Top Gear.

Possible Cause.

1. Accelerator pump defective, or faults in its circuit.
2. Emulsion tube blocked or defective in other ways.

Suggested Remedy.

- Thoroughly overhaul pump and its circuit.  
Replace emulsion tube.



Key to Fig.34 - CARBURETTER COMPONENTS

- |   |  |
|---|--|
| 1. Choke  | 52. Plug, progression holes inspection |
| 2. Auxiliary venturi                            | 53. Plug, pressure connection          |
| 3. Jet, main                                    | 54. Plug, delivery valve seat          |
| 4. Jet, idling                                  | 55. Stuffing, delivery valve           |
| 5. Jet, pump                                    | 56. Outlet valve                       |
| 6. Jet, starting                                | 57. Gasket                             |
| 7. Emulsion tube, main                          | 58. Nut                                |
| 8. Emulsion tube, starting                      | 59. Plate, retaining                   |
| 9. Jet, main air corrector                      | 60. Spacer                             |
| 10. Jet, idling air corrector                   | 61. Washer, distance                   |
| 11. Needle valve                                | 62. Ball bearing                       |
| 12. Float                                       | 63. Spring, pump diaphragm             |
| 13. Screw, securing choke cable                 | 64. Pump diaphragm                     |
| 14. Support, choke cable                        | 65. Washer                             |
| 15. Plug, starting valve seat                   | 66. Spring, pump rod                   |
| 16. Spring, starting valve                      | 67. Nut                                |
| 17. Starting valve                              | 68. Nut                                |
| 18. Cover, float chamber                        | 69. Pump cover                         |
| 19. Gasket, float chamber cover                 | 70. Washer, spring                     |
| 20. Gasket, needle valve                        | 71. Screw, pump cover fixing           |
| 21. Screw, jet cover fixing                     | 72. Gasket, pump body                  |
| 22. Washer, spring                              | 73. Pump body                          |
| 23. Jet cover                                   | 74. Inlet valve                        |
| 24. Screw, securing float chamber cover         | 75. Gasket, inlet valve                |
| 25. Gasket, jet cover                           | 76. Screw, auxiliary venturi fixing    |
| 26. Washer, spring                              | 77. Nut, fixing screw                  |
| 27. Control shaft, starting valve               | 78. Stud                               |
| 28. Washer, spring                              | 79. Spring, throttle shaft return      |
| 29. Plug, starting shaft                        | 80. Screw, pump control lever fixing   |
| 30. Control lever, starting valve               | 81. Rod, lever and pump control        |
| 31. Return spring, starting lever               | 82. Throttle                           |
| 32. Bush, starting lever return spring          | 83. Screw, throttle fixing             |
| 33. Washer, spring                              | 84. Washer, spring                     |
| 34. Nut   | 85. Screw, pump body fixing            |
| 35. Gasket, banjo union (fuel pipe)             | 86. Shaft, throttle                    |
| 36. Float pin                                   | 87. Pin, split                         |
| 37. Union, banjo (fuel pipe) - rear carburetter | 88. Pin, control lever                 |
| 38. Filter, petrol                              | 89. Spring, pin                        |
| 39. Gasket, plug securing banjo                 | 90. Control Lever                      |
| 40. Plug, banjo                                 | 91. Screw, control lever               |
| 41. Union, banjo (fuel pipe)-front carburetter  | 92. Washer, spring                     |
| 42. Lever, throttle control                     | 93. Screw, fixing                      |
| 43. Screw, adjusting                            | 94. Rod                                |
| 44. Spring, adjusting screw                     | 95. Washer, plain                      |
| 45. Washer, plain                               | 96. Screw, securing cable              |
| 46. Gasket                                      | 97. Gasket                             |
| 47. Screw, idling mixture adjustment            | 98. Screw, horn retaining              |
| 48. Spring, screw                               | 99. Nut                                |
| 49. Plug, pump jet                              | 100. Washer, spring                    |
| 50. Gasket, pump jet                            | 101. Air horn                          |
| 51. Gasket, pump jet                            | 102. Throttle spring                   |
| 1072.   |  |

L.27 - DELLORTO CARBURETTERS .To Remove

1. Release the clip securing the air cleaner trunking to the air box. Remove the bolts visible in the air box and pull off outer half of box.
2. Release the throttle return spring and throttle cable. Disconnect the fuel supply pipes at the carburetters. Remove the choke cable.
3. Progressively release the nuts securing the carburetters to the engine (four are visible from above, the other four being below). Remove nuts and washers.
4. Carefully remove the two carburetters as an assembly, ensuring that the synchronising linkage between the two is not distorted. Remove the spacers with their 'O' rings from the mounting studs.

To Replace .

1. Ensure that the spacers and 'O' rings are in good condition - the slightest mark will result in an air leak which will seriously affect the efficient running of the carburetters. Fit the spacer assemblies to the mounting studs.
2. Fit the carburetters as an assembly, ensuring that the synchronising linkage has not been disturbed. To each mounting stud fit a double coil spring washer, a plain washer and nut. Tighten the eight nuts progressively until a .040 in. (1.02 mm.) clearance exists between the carburetter flanges and the spacers. Check with feeler gauges. Do NOT overtighten the nuts otherwise the 'O' rings will be flattened into the recesses of the spacer plates, but more important, with the carburetters rigidly mounted, frothing will occur in the float chambers.
3. Refit the fuel supply pipes to the carburetters. Reconnect the choke control, throttle cable and throttle return spring.
4. Ensure that the gasket is in good condition between the two halves of the air box, then refit outer half. Reconnect the air trunking to the air box.

To Adjust

The only adjustments required are synchronisation, mixture strength and idling speed. These adjustments are covered in Section 'L.26' under the sub-heading 'Synchronisation' (Fig. 32.)

L.28 - FUEL CUT-OFF VALVE

To Install

1. Remove the fuel feed pipe from the front carburetter, and cut off 6 in. (15 cm.), approximately.
2. Bend the remaining length of the pipe beneath the airbox until its cut end is facing the bonnet aperture side, ensuring that it is not chafing on any sharp edges. Remove the pipe support strap from the front carburetter, and discard.
3. Attach a ring terminal to one end of the earth cable, and the fork terminal to the other end of the earth cable. Slacken the earth terminal bolt beneath the recuperator bottle, and insert fork terminal end between the other earth terminals. Tighten the bolt.
4. Fit a hose clip to each end of one of the rubber sleeves, and fit sleeve to existing fuel pipe beneath the airbox. Into other end of sleeve, insert the cut-off valve, ENSURING that arrow marked on valve CORRESPONDS WITH THE DIRECTION OF FUEL FLOW. Using the valve as a guide, drill two holes in the rear sloping face of the wheelarch, in such a position that the ring terminal of the earth cable (see '3') can be secured by the screw retaining the valve, and also to achieve a neat pipe run. Secure the valve to the wheelarch with the pan head screws, under one of which is fitted the ring terminal. Tighten the clips securing the sleeve to the fuel pipe.
5. Cut off both the existing connectors from the fuse holder, replacing with 'Lucar' type connectors. Insert the fuse. Attach one end of this cable to the extension on the cut-off valve; to the other end, attach a 'piggy-back' connector, this in its turn being attached to:
  - R.H.D. cars - live side of brake lamp switch
  - L.H.D. cars - to ignition switch (lengthen cable)
6. Fit the remaining clips to the remaining sleeve, and attach sleeve to the outlet side of the cut-off valve.
7. Fit other end of sleeve to the nylon pipe; heat the free end of this pipe in boiling water, shake off surplus water, and push pipe end onto the carburetter inlet connector, allowing the pipe end to cool naturally. Tighten all hose clips.
8. Finally, start engine and check all pipe connections for leaks, tightening clips if necessary. Switch 'off' engine.

