

SECTION R

FINAL DRIVE

<u>Section</u>	<u>Description.</u>	<u>Page No.</u>
R. 1	Differential - General Description.	3
R. 2	Differential - Remove and Replace.	3
R. 3	Differential - Overhaul.	5
R. 4	Propeller Shaft.	13
R. 5	Intermediate Drive Shaft.	19
R. 6	Rotoflex Couplings	19
-	Outboard Drive Shafts (see Section 'G').	
-	Hubs (see Section 'G').	
	<u>Additional Information</u>	
R. 7	Differential Unit Replacement (S130)	21

ILLUSTRATIONS.

<u>Fig. Nos.</u>	<u>Description.</u>	<u>Page No.</u>
1.	Final Drive Arrangement.	4.
2.	Filler/Level Plug.	4.
3.	Washer Sequence.	4.
4.	Differential Unit Components.	6.
5.	Bearing Cap Markings.	8.
6.	Planet Gears & Carrier.	8.
7.	Spider Shaft Location.	8.
8.	Setting Depth Gauge.	10.
9.	Measuring Pinion Mesh.	10.
10.	Assembling Pinion.	10.
11.	Measuring Backlash.	12.
12.	Correct Tooth Contact.	12.
13.	Incorrect Tooth Contact.	14.
14.	Sliding Splines & Front Universal.	16.
15.	Propeller Shaft Components.	16.
16.	Removing Bearings.	18.
17.	Tapping Out Bearings.	18.
18.	Fitting Gaskets.	18.
19.	Intermediate Drive Shaft & Rotoflex Coupling.	20.
20.	Coupling Bolts.	20.

DIFFERENTIAL.

R. 1 - GENERAL DESCRIPTION.

The differential unit is flexibly mounted at both its upper and lower securing points. The crown wheel and pinion are mounted in the differential carrier, which is bolted to the front face of the differential casing.

Adjustments are provided for pinion bearing pre-load, crown wheel and pinion backlash and pinion depth of mesh.

Lubrication.

The combined filler/level plug is located in the rear of the housing, and the drain plug in the lower right front of the housing. When checking the oil level the car should be standing on level ground. Remove the level plug and check that the oil level is up to the bottom of the hole. If necessary, add oil (see Section 'O') to bring it to this level. Refit the level plug and tighten it securely.

R. 2 - DIFFERENTIAL UNIT.

To Remove.

1. Remove the rear wheels (see Section 'G').
2. From inside the car, remove the rear seat backrest (see Section 'B').
3. Disconnect the left-hand lower wishbone (see Section 'D'). Remove the Rotoflex couplings (Section 'R.6').
4. Disconnect the propeller shaft from the differential driving flange. Disconnect the forward ends of the differential torque rods from their location on the chassis.
5. From inside the car, remove the differential unit retaining bolt nuts which pass through the chassis rubber mountings, the nuts being located beneath the fuel tank.
6. From below the car, withdraw the differential unit from the left-hand side.

To Replace.

1. Lift the differential unit into position from the left-hand side and adjust unit to give a clearance between the top of the unit and the chassis crossmember. This may necessitate the removal of one of the two washers on either or both sides. A minimum of one washer must be left between the top lugs of the differential unit and the chassis crossmember and between the head of the bolt

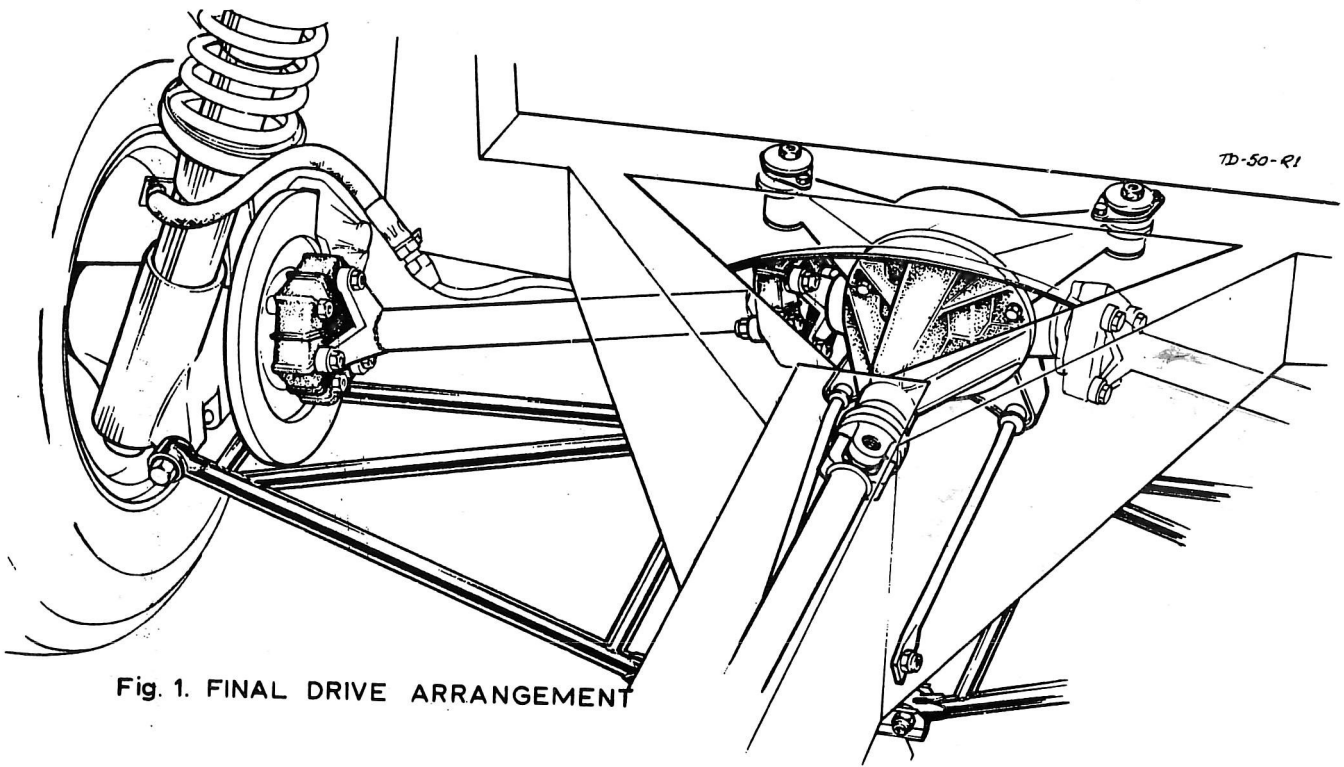

Fig. 1. FINAL DRIVE ARRANGEMENT

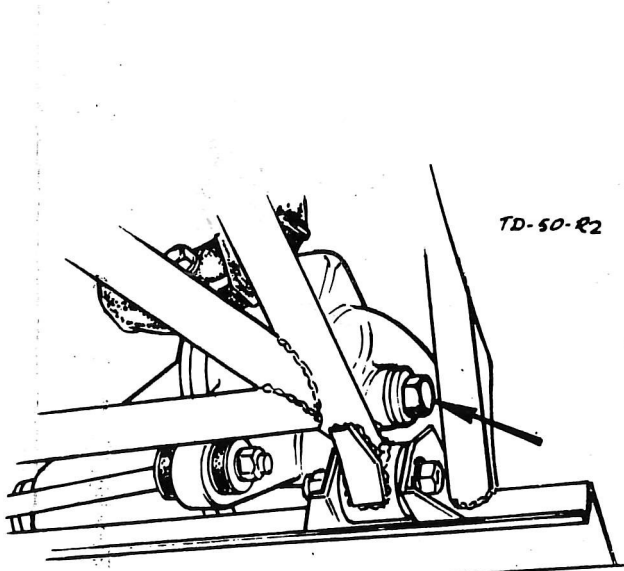

Fig. 2. FILLER/LEVEL PLUG

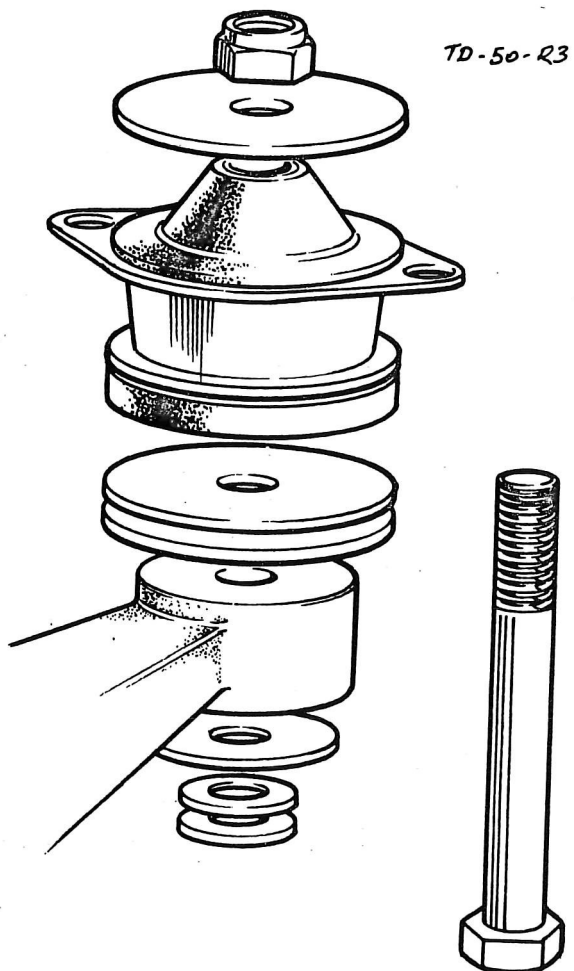

FIG. 3. WASHER SEQUENCE.

and the rubber mountings. It is essential that the large 2 in. (5 cm.) diameter washers are used and not substituted by others, as they serve a twofold purpose in being both spacers and stopping the rubber bushes from spreading. Harder differential mounting rubbers (Part No. A36 R 6000) were introduced at Chassis No. 50/1550. New bolts (Part No. 50 R 027) which secure the differential to the mountings were introduced at Chassis No. 50/1880. Two washers (Part No. 26 R 003) are now fitted between the differential and its mounting rubbers, this change being incorporated into current Production from Chassis No. 50/1645.

2. Attach the forward ends of the differential unit torque rods, following with the propeller shaft retaining nuts and bolts. Reconnect the left hand lower wishbone, ensuring the spacer washers are located between the wishbone and the bearing housing. Note that the long bolt is fitted towards the front of the car. The torque rod rubbers (at the differential end) are assembled in the following sequence from the front:
 - rubber bush (next to fixed washer), cupwasher with large hole, differential unit lug, cup washer with large hole, rubber bush, cup washer with small hole, and finally the nut which should be torque loaded to the figure given in 'TECHNICAL DATA'.
3. Attach the outer end of the drive shaft to its Rotoflex coupling, (see Section 'R.5' and 'R.6'), ensuring that the brake disc is running true within the caliper. Torque load the nuts to the figure given in 'TECHNICAL DATA'.
4. Jack up the left-hand bearing housing from below the damper, to enable the inner end of the drive shaft to be attached to the other Rotoflex coupling (see Section 'R.5' and 'R.6'). It will be found easier to insert a bolt through the upper hole in the coupling and the lower hole in the driving flange, finger tightening the bolt. The other bolts can now be fitted by rotating the shaft around the one fixing bolt, inserting the bolts from the driving shaft side. Finally torque load all nuts to the figure given in 'TECHNICAL DATA' and remove the coupling clamps.
5. Fit handbrake rod to caliper (see Section 'J').
6. Replace the rear seat backrest (see Section 'B').
7. Refit road wheels. Finally, refill the differential with the specified oil (see Section 'O').

R. 3 - DIFFERENTIAL UNIT.

Overhaul.

1. Remove the differential unit (Section 'R.2') to a clean bench. Drain the oil

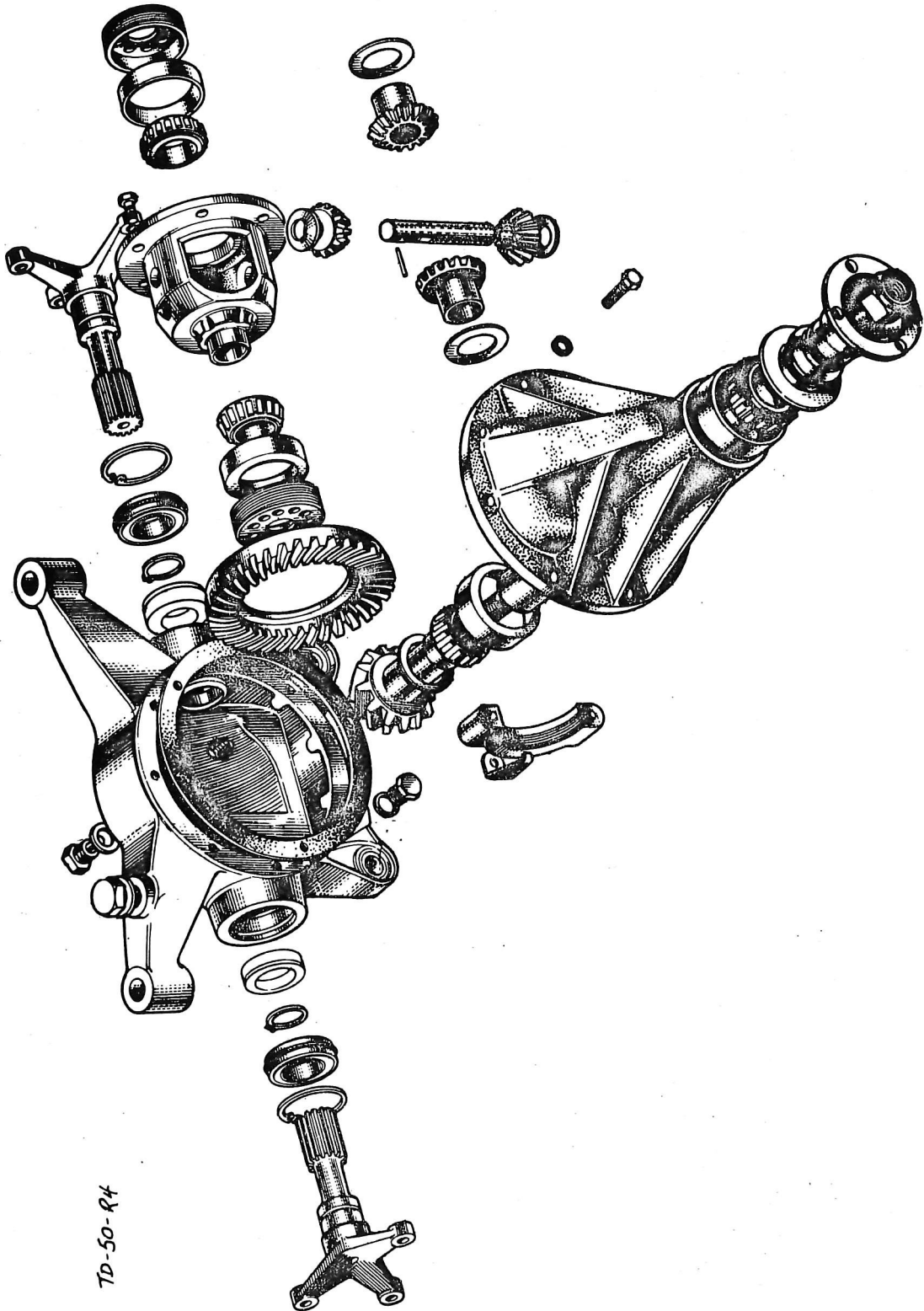

TD-50-R4

Fig. 4. DIFFERENTIAL UNIT COMPONENTS

- into a suitable receptacle.
2. Remove the circlip on either side of the outer bearing housing and gently tap out each drive shaft.
 3. Remove the bolts holding the differential carrier assembly to the differential casing and lift out the differential carrier assembly complete.
 4. Unscrew the bolts of the adjustment nut locking plate. Detach the plates. Note carefully that the bearing caps are marked for mating purposes and slacken the bearing adjustment nuts using a special creeper spanner (Tool No. P.4079) and detach the bearing caps after removing their bolts and lockwashers.
 5. The crown wheel assembly can now be carefully removed complete with bearings and adjustment nuts. (Note that each bearing should be kept with its corresponding cup). Unscrew the nut securing the drive pinion to the propeller shaft coupling flange, after carefully removing the staking from the flange. Withdraw the coupling flange from the pinion shaft. The pinion complete with its rear bearing assembly and spacer can now be withdrawn from the rear of the housing. Remove the pinion bearing cups and drive the front bearing and oil seal forwards out of the housing. Drive out the remaining rear pinion bearing cup from the front of the housing.
 6. To dismantle the pinion assembly it is first necessary to remove the spacer from the shaft in the following manner: Place the unit on the bed of a suitable hand press. Make sure that the bearing cage is not fouling, then press out the pinion.
 7. To dismantle the crown wheel and differential assembly, unscrew the lock bolts securing the crown wheel to the differential cage. Press the cage through the crown wheel. Drive out the taper pin situated in one end of the spider shaft away from the crown wheel side of the cage. Push the differential pinion shaft through the cage and extract the two pinions. Remove the conical thrust washers at the same time. Withdraw the two axle shafts gears and their thrust washers from the cage. Support the assembly on the bed of a hand press and press off the bearing cones taking care that the roller cage is not damaged in the process. Clean all components and inspect for wear or damage, replacing where necessary.
 8. Re-assembly is basically a reversal of the dismantling procedure. **However**, where new components have been included, it should be noted that all adjustments will be affected. Care must therefore be exercised in re-assembly to obtain (a) the correct pinion bearing engagement by using the correct shim, (b) the correct pinion bearing preloading, (c) the correct crown wheel and pinion backlash and (d) the correct differential bearing pre-loading.

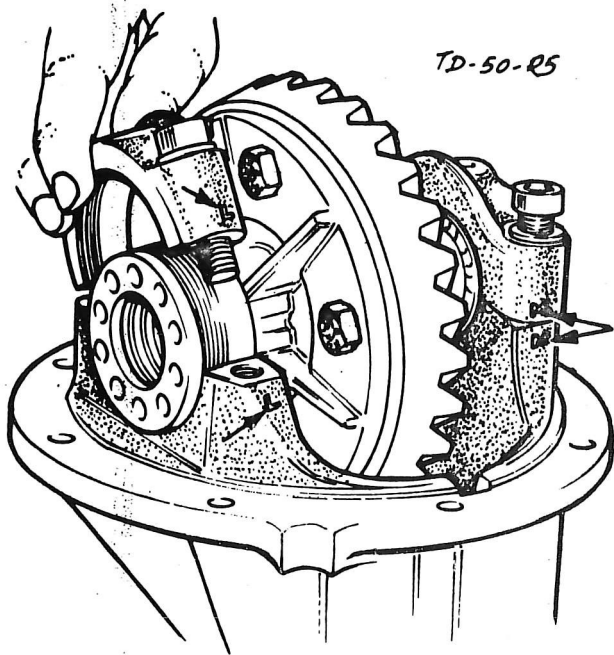

Fig. 5. BEARING CAP MARKINGS

TD-50-R6

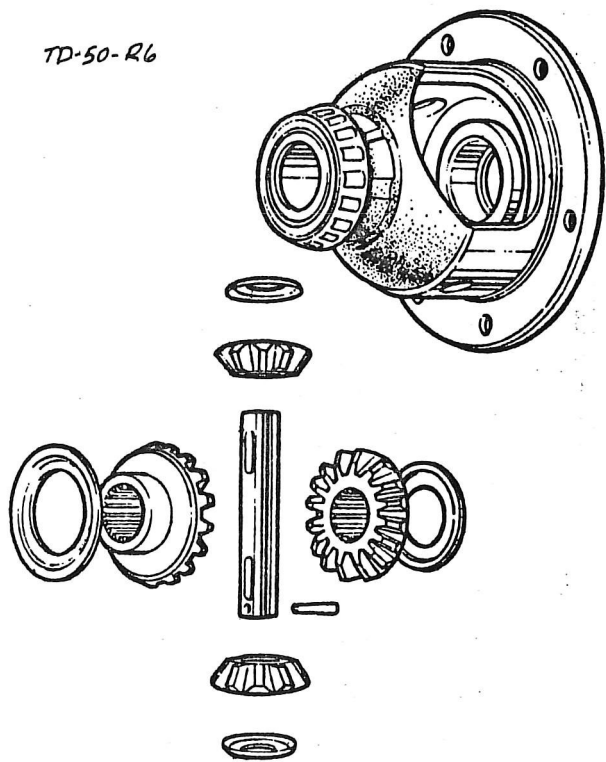

Fig. 6. PLANET GEARS & CARRIER.

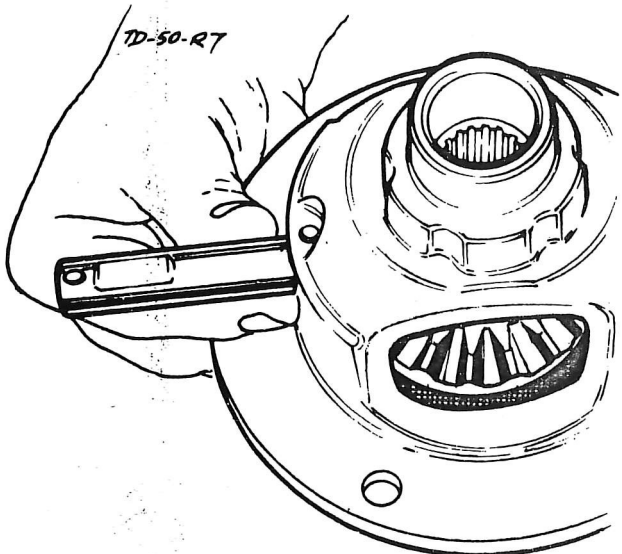

Fig. 7. SPIDER SHAFT LOCATION

9. Lubricate the thrust washers and place them on the rear faces of the axle shaft gears. Insert the gears in the differential cage, then lubricate the conical thrust washers and locate behind each differential pinion. Place the pinions in the apertures of the cage diametrically opposite each other and rotate the axle shaft gears so that the hole for the spider shaft in the cage aligns the pinions.
10. Insert the spider shaft after making sure that the taper pin hole will line up with its corresponding hole in the cage. Push the spider shaft home and insert the taper pin from the differential side of the cage. Drive the taper pin home and lightly peen over the cage.
11. Locate the crown wheel on the cage and enter three bolts as pilot guides through the wheel and cage and press on using a suitable hand press and differential bearing cone. Remove the three bolts used as pilot guides and replace with six lock bolts tightening them to the torque loading given in 'TECHNICAL DATA'. Press the differential driving cones into the cage.
12. To fit the pinion bearing cups place the rear one on Tool No. P.4013-3 and insert through the carrier from the rear. Place the front bearing cup, followed by loose adaptor and wing nut to the centre bolt of the tool now protruding from the front of the carrier. Tighten the wing nut pressing both cups fully home. Unscrew the wing nut and remove the tool. To select the correct shim to control the pinion bearing engagement, the following procedure must be adhered to.
13. Using Tool No. P.4075-4 (in effect a driving pinion), slide the rear bearing onto its location, the larger diameter of the bearing being towards the pinion flange and fit the assembly to the differential carrier. Slide the front bearing cone with its smaller diameter inwards onto the tool and fit the drive shaft flange onto the pinion shaft splines. Fit the old pinion drive flange nut. Pre-load the pinion bearings by holding the drive flange with the Tool No. P.4028 and tighten the flange nut, whilst turning the pinion backwards and forwards to ensure the bearing rollers are seating correctly. Continue this operation until the rotation indicates that the bearings are correctly seated by an even bearing drag. Fit the pre-load gauge (Tool No. CP.4030) with pinion bearing at pre-loaded running torque of between 9 and 11 lbs. in. (.104 to .127 kg.m.). Should this pre-loading be exceeded, then slacken the flange nut to relieve bearings of any pre-loading and re-tighten to correct setting.
14. The depth of engagement between pinion and crown wheel is dependent on the insertion of a suitable shim between the rear pinion bearing cone and the front face of the pinion. A depth gauge tool (Tool No. P.4075-3) in conjunction

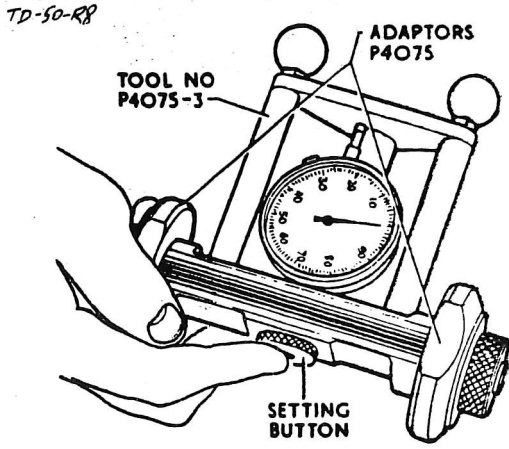

Fig. 8. SETTING DEPTH GAUGE

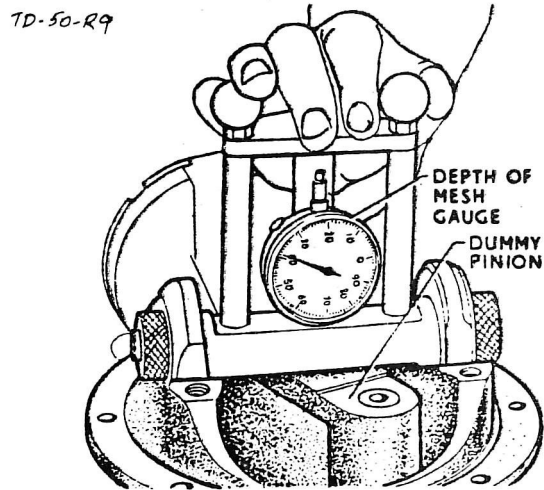

Fig. 9. MEASURING PINION MESH

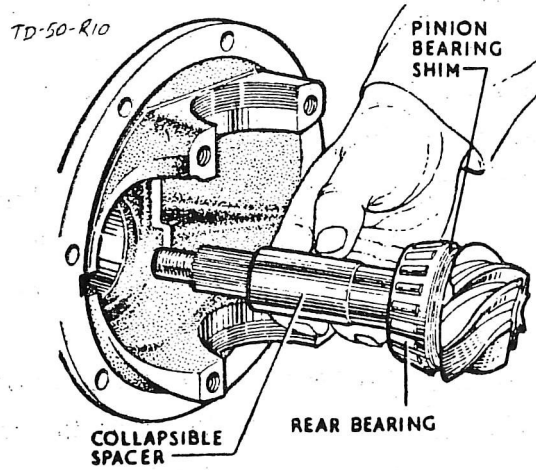

Fig. 10. ASSEMBLING PINION

with adapters (Tool No. P.4075) is used to determine the correct thickness of the shim required.

15. Set the gauge to zero by operating the setting button beneath the tool. Ensure that the bearing locations are clean, set the tool so that the gauge plunger rests on the upper face of the driving pinion tool and check that a minimum reading is obtained by rocking the gauge slightly backwards and forwards.

16. To obtain the actual thickness of shim required it is necessary to add .10 in. (2.54 mm.) to the reading given by the gauge, i.e. a dial reading of 39 (as shown in Fig. 9) would require a shim of .139 in.

It should be mentioned at this juncture that etched markings may exist on the taper portion of any pinion shaft between the two bearing locations. This will affect the shim thickness accordingly and where the figure exists with a plus (+) sign it should be added to that of the gauge figure, or in the case of a minus (-) sign subtracted from the reading.

17. Dismantle the driving pinion tool and unscrew the preload gauge adapter nut, pull off the drive flange and front bearing cone and remove driving pinion and rear bearing cone from the rear of the housing. Fit the selected shim with the internal chamfer on the shim towards the gear teeth with the aid of Tool No. P.4000-28 press the bearing home on the pinion. Assemble the front pinion bearing cone and cup and locate the oil seal in the axle throat with its lip towards the bearing. Press the seal home using Tool No. 4013-3. Oil the seal slightly and fit the pinion into the front pinion bearing complete with a new collapsible spacer. Having replaced the drive flange retaining nut tighten the nut until there is very little end float on the pinion shaft. Check the torque required to rotate the assembly and add this figure to the pre-load figure of 9 - 11 lbs.in. for the pinion bearing above. The pinion must be rotated continuously whilst the drive flange retaining nut is being tightened to the correct reading to ensure correct seating of the bearing rollers. If the pre-load is exceeded the assembly must be dismantled and a new spacer fitted to the pinion. Once the correct loading has been obtained lock the drive flange retaining nut to the pinion with a suitable punch.
18. Correct tooth contact depends upon the adjustment of the crown wheel and pinion backlash and differential bearing pre-load. Locate the differential bearing cups on their cones and position the assembly on the carrier housing ensuring that the bearing cups are square on the rollers.
19. Bolt the bearing caps in place ensuring that the mating marks correspond but do not fully tighten at this stage. Refit the differential bearing adjusting nuts. To fit the bearing cap spread gauge (Tool No. P.4009) bolt one of the adjustment nut locking plates upside down on the bearing cap. Locate the

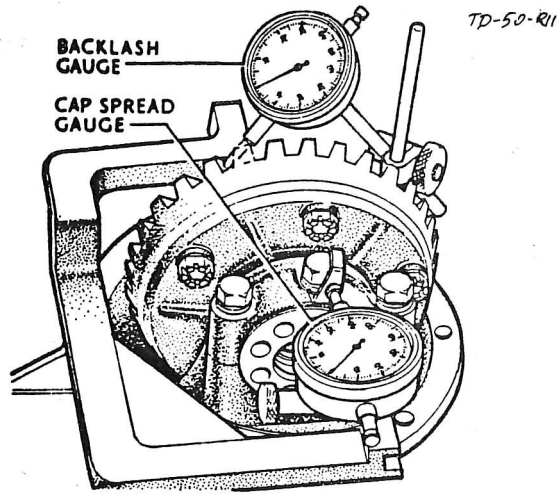

Fig. 11. MEASURING BACKLASH

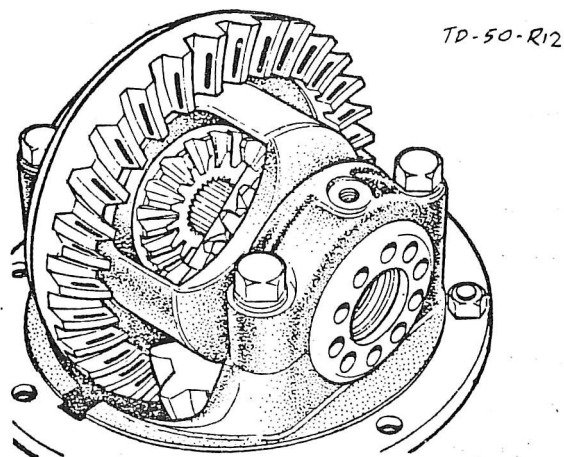

Fig. 12. CORRECT TOOTH CONTACT

plunger of the gauge on the vertical face of the locking plate. Set the gauge at zero and tighten the bearing adjusting nuts until there is only slight backlash between the crown wheel and pinion. Rotate the crown wheel during this operation to ensure the correct seating of the bearing rollers. Bolt the backlash gauge (Tool No. P.4008-1) to the differential carrier flange so that the gauge plunger may be rested on the heel of a crown wheel tooth and perpendicular to it. Having set the gauge at zero adjust the backlash by means of the differential bearing adjustments to a reading of between .001 and .002 in. (.025 to .050 mm.). The last one to be tightened is the nut on the crown wheel side. Moving the backlash gauge aside screw in the bearing adjusting nut on the differential side until a constant cap spread reading of .005 - .007 in. (.127 - .178 mm.) is obtained. Re-position the backlash gauge and holding the pinion rock the crown wheel to-and-fro. The final reading of the backlash between the crown wheel and pinion should be .005 - .007 in. (.127 - .178 mm.). If the backlash is outside these limits readjustments should be made by slackening the adjusting nut on one side and tightening the adjusting nut on the other side by the same amount, final tightening always occurring on the crown wheel side. Fit the adjusting nut locking plates, tightening the retaining bolts and the differential cap retaining bolts to the torque loading given in 'TECHNICAL DATA'.

20. To check the tooth contact of the crown wheel and pinion apply a thin coat of read lead, yellow ochre or engineers blue to the crown wheel teeth. Fit the inboard drive shafts to the differential gears and rotate the pinion in both directions, holding the shafts to provide a load. If the crown wheel and pinion have been adjusted correctly, the area of contact will be as shown in Fig.12. Incorrect markings are shown in Fig.13.
21. Using a new gasket coated on both sides with a suitable jointing compound, refit the differential carrier assembly to the differential casing. Secure with the retaining bolts.
22. Insert the drive shafts, retaining with their circlips. Rotate the shafts to check freedom of movement.
23. Fill the differential unit with the specified oil (see Section 'O').
24. Replace the differential unit (Section 'R.2').

R. 4 - PROPELLER SHAFT.

Description.

A single shaft connects the rear axle and the gearbox. To accommodate for and aft movement of the axle a sliding joint of the reverse spline type is fitted

TD-50-R13

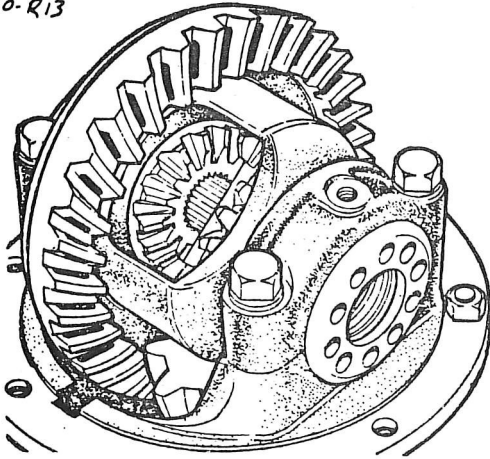

Heavy Flank Contact

In this case the area of contact is below the centre line of the tooth, and the condition should be rectified by moving the pinion away from the crown wheel, using a thinner shim behind the pinion. Reset the backlash and differential bearing pre-load.

TD-50-R14

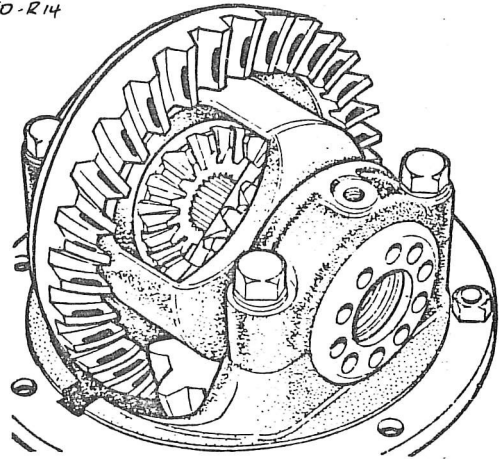

Heavy Face Contact

In this case the area of contact is above the centre line of the tooth, due to the pinion being too far away from the crown wheel. Use a thicker pinion bearing shim to lower the contact area and reset the backlash and differential bearing pre-load.

TD-50-R15

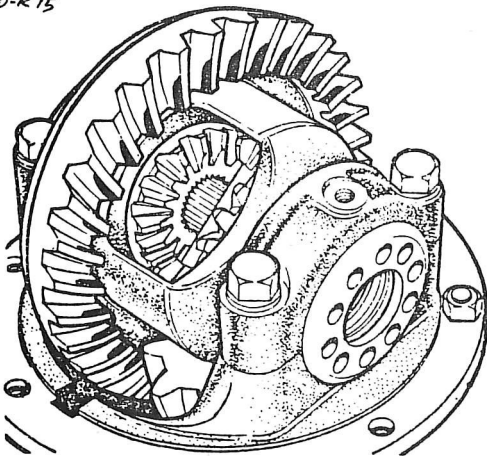

Contact on Toe

When the area of contact is running off the toe of the pinion, move the crown wheel away from the pinion. Slacken the crown wheel adjusting nut and screw in the differential side nut an equal amount. It may also be necessary to use a thicker shim behind the pinion in order to keep the backlash within the correct limits.

TD-50-R16

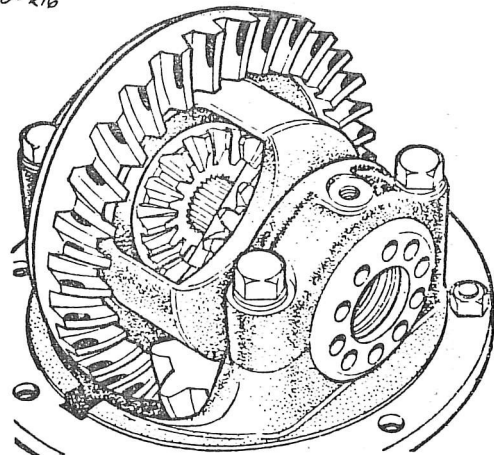

Contact on Heel

In this case the crown wheel is too far out from the pinion. Slacken the differential side adjusting nut and tighten the crown wheel side nut, re-check the backlash and differential bearing pre-load readings. If the backlash is reduced below the minimum specified, use a thinner shim behind the pinion and, using a new collapsible spacer, readjust pinion bearing pre-load.

Fig. 13. INCORRECT TOOTH CONTACT

276

between the gearbox and the front universal joint flange. Each joint consists of a centre spider, four needle-roller bearing assemblies, and two yokes.

Lubrication.

The needle roller bearings are of the "sealed-for-life" type and require no other form of lubrication in service.

The sliding joint is automatically lubricated from the gearbox.

Testing for Wear.

Wear on the thrust faces is ascertained by testing the lift in the joint either by hand or with the aid of a length of wood suitably pivoted.

Any circumferential movement of the shaft relative to the flange yokes indicates wear in the needle-roller bearings or in the splined shaft in the case of the forward joint.

To Remove.

1. Mark the mating flanges of the rear joint and the differential to ensure that they are replaced in their original positions.
2. Support the gearbox with a screw jack and remove the gearbox mounting.
3. Remove the bolts with their nuts securing the propeller shaft to the differential unit driving flange.
4. Pull the propeller shaft rearwards to free the sliding splines, then remove shaft by pulling forwards, lowering the gearbox at the same time with the aid of the screw jack.

Overhaul.

1. Remove the enamel and dirt from the snap rings and bearing faces. Remove all the snap rings by pinching their ears together with a pair of thin-nosed pliers and prising them out with a screwdriver.
2. If a ring does not slide out of its groove readily tap the end of the bearing race slightly to relieve the pressure against the ring.
Holding the joint in one hand, tap the radius of the yoke lightly with a copper hammer, as shown in Fig.16. The bearing should begin to emerge; turn the joint over finally remove with the fingers.
If necessary, tap the bearing race from inside with a small-diameter bar, as shown in Fig.17, taking care not to damage the bearing face, or grip the needle bearing race in a vice and tap the flange yoke clear.

TD-50-R17

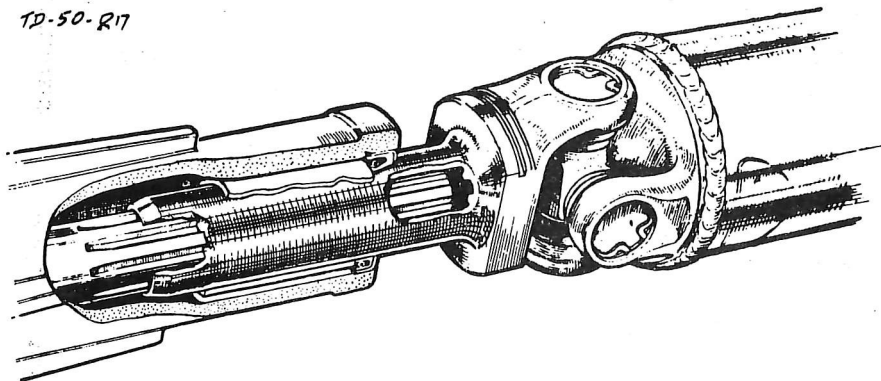

Fig. 14. SLIDING SPLINES & FRONT UNIVERSAL

TD-50-R18

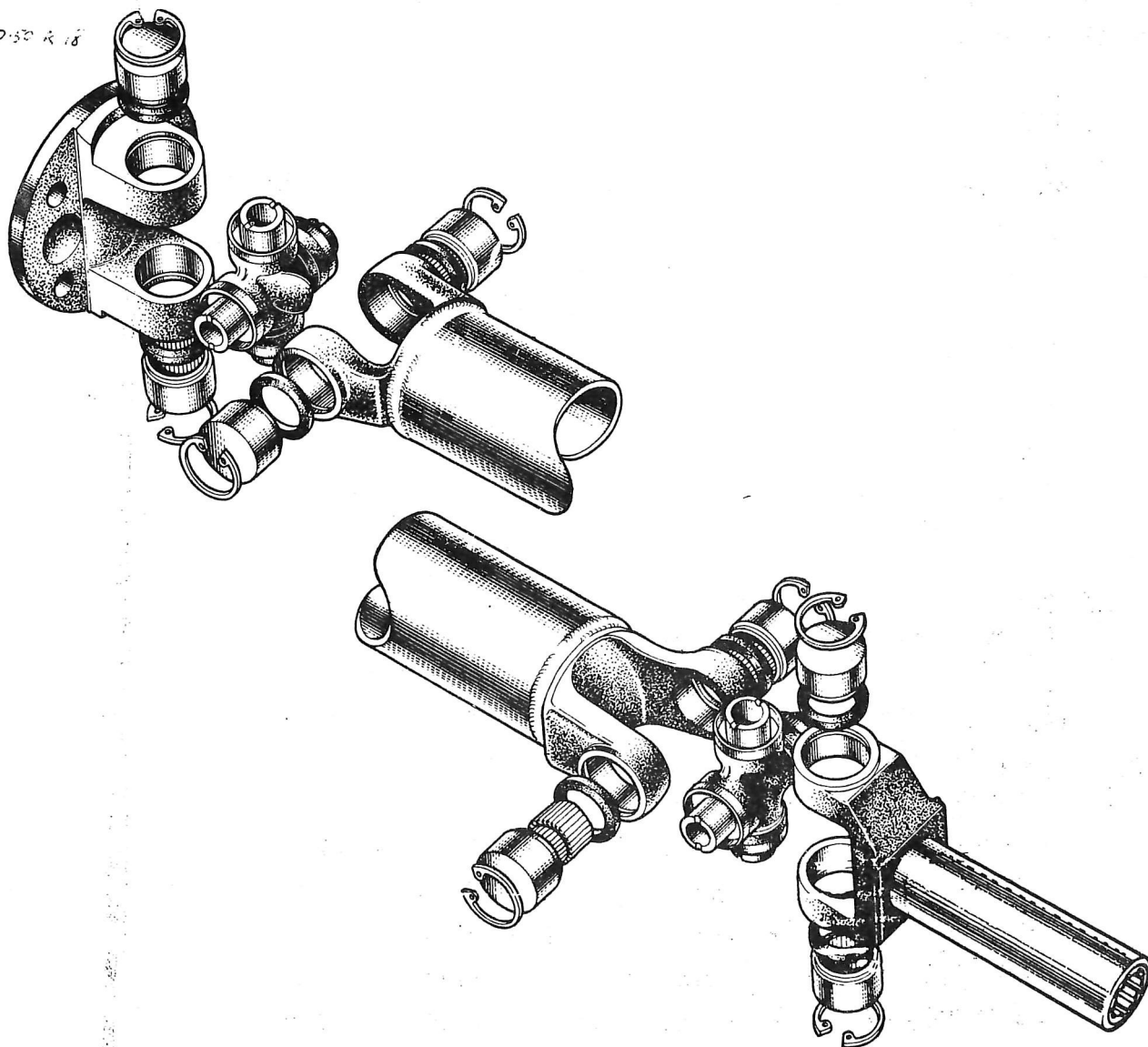

Fig. 15. PROPELLOR SHAFT COMPONENTS

3. Hold the bearing in a vertical position, and when free remove the race from the bottom side to avoid dropping the needle-rollers.
4. Repeat this operation for the opposite bearing.
5. Rest the two exposed trunnions on wood or lead blocks to protect their ground surfaces and tap the top lug of the flange yoke to remove the bearing race.
6. Turn the yoke over and repeat this operation.

To Examine for Wear.

1. The parts most likely to show signs of wear after long usage are the bearing races and the spider journals. Should looseness, load markings, or distortion be observed, the affected part must be renewed complete; no oversize journals or races are provided.
2. It is essential that the bearing races are a light drive fit in the yoke trunnions. In the event of wear taking place in the yoke cross-holes, rendering them oval, the yokes must be renewed. In case of wear in the cross-holes in the fixed yoke, which is part of the tubular shaft assembly, it should be replaced by a complete tubular shaft assembly.

To Re-assemble.

1. It is always advisable to replace the cork gasket and the gasket retainers on the spider journals by means of a tubular drift. The spider journal shoulders should be shellacked prior to fitting the retainers to ensure a good oil seal.
2. Assemble the needle-rollers in the bearing races and fill with grease. Should difficulty be experienced in retaining the rollers under control, smear the walls of the races with grease (see Section 'O') to retain the needle-rollers in position while re-assembling.
3. Insert the spider in the flange yoke. Using a soft nosed drift, about .03 in. (.8 mm.) smaller in diameter than the hole in the yoke, tap the bearing into position. Repeat this operation for the other three bearings. Replace the circlips and be sure that these are firmly located in their grooves. If the joint appears to bind, tap lightly with a wooden mallet; this will relieve any pressure of the bearings on the end of the journals.

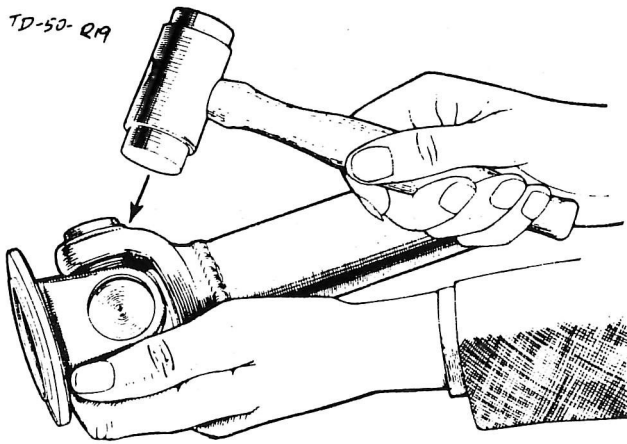

Fig. 16. REMOVING BEARINGS

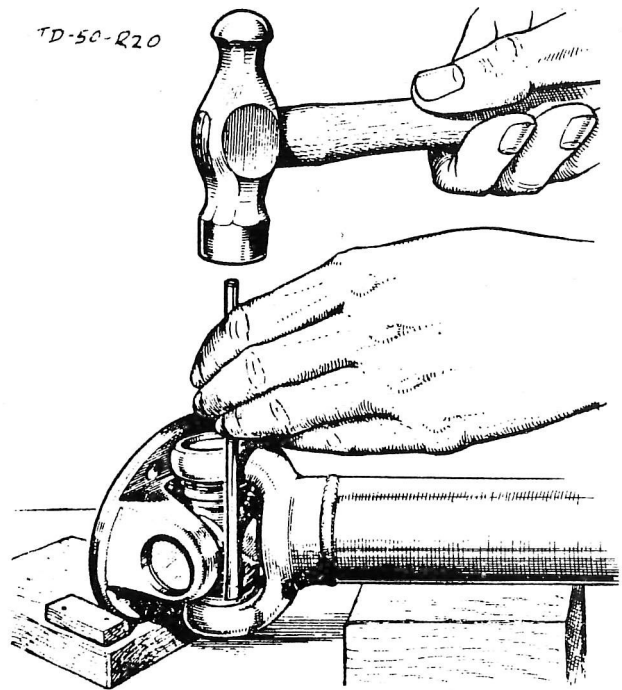
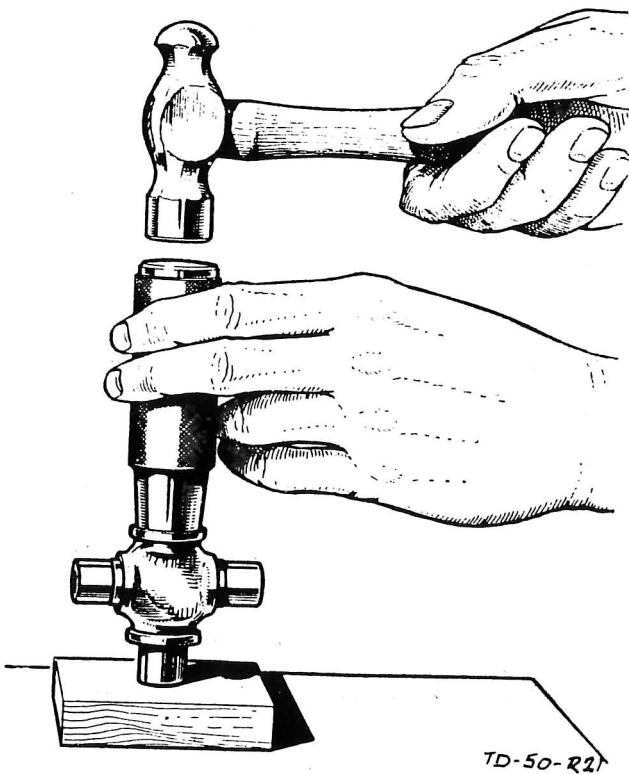

Fig. 17. TAPPING OUT BEARINGS



TD-50-R21

Fig. 18. FITTING GASKETS

To Replace.

1. Replacing the propeller shaft is a direct reversal of the removal procedure. Ensure that all flanges are clean, and that their spigots engage correctly before tightening the securing nuts.

R. 5 - INTERMEDIATE DRIVE SHAFT.

To Remove.

1. Raise the rear wheel on the side of the car from which the shaft is to be removed, until the Rotoflex couplings adopt as near a true shape as possible. Place a clamp around the couplings to prevent distortion when they are removed.
2. Release the three bolts and nuts from each end of the shaft and remove shaft.

To Replace.

1. Replacing the shaft is a direct reversal of the removal procedure, noting that washers if originally fitted, should be discarded from under the nuts. All nuts must be of the nyloc type. Tighten bolts to the torque loadings given in 'TECHNICAL DATA'.

R. 6 - ROTOFLEX COUPLINGS.

To Remove.

1. Remove the intermediate drive shaft (Section 'R.7').
2. Remove the remaining three bolts and nuts securing the couplings, noting that the bolts securing the outer couplings also retain the brake discs.

To Replace.

1. Note that when replacing couplings there is a correct way to fit. Inspection of the coupling will show that the metal bosses are offset in the rubber, three each way. Correct fitting is with the three 'high' bosses on each face in contact with the flanges of drive shaft (Fig.19). Incorrect fitting will result in the drive shaft overall length being affected with a

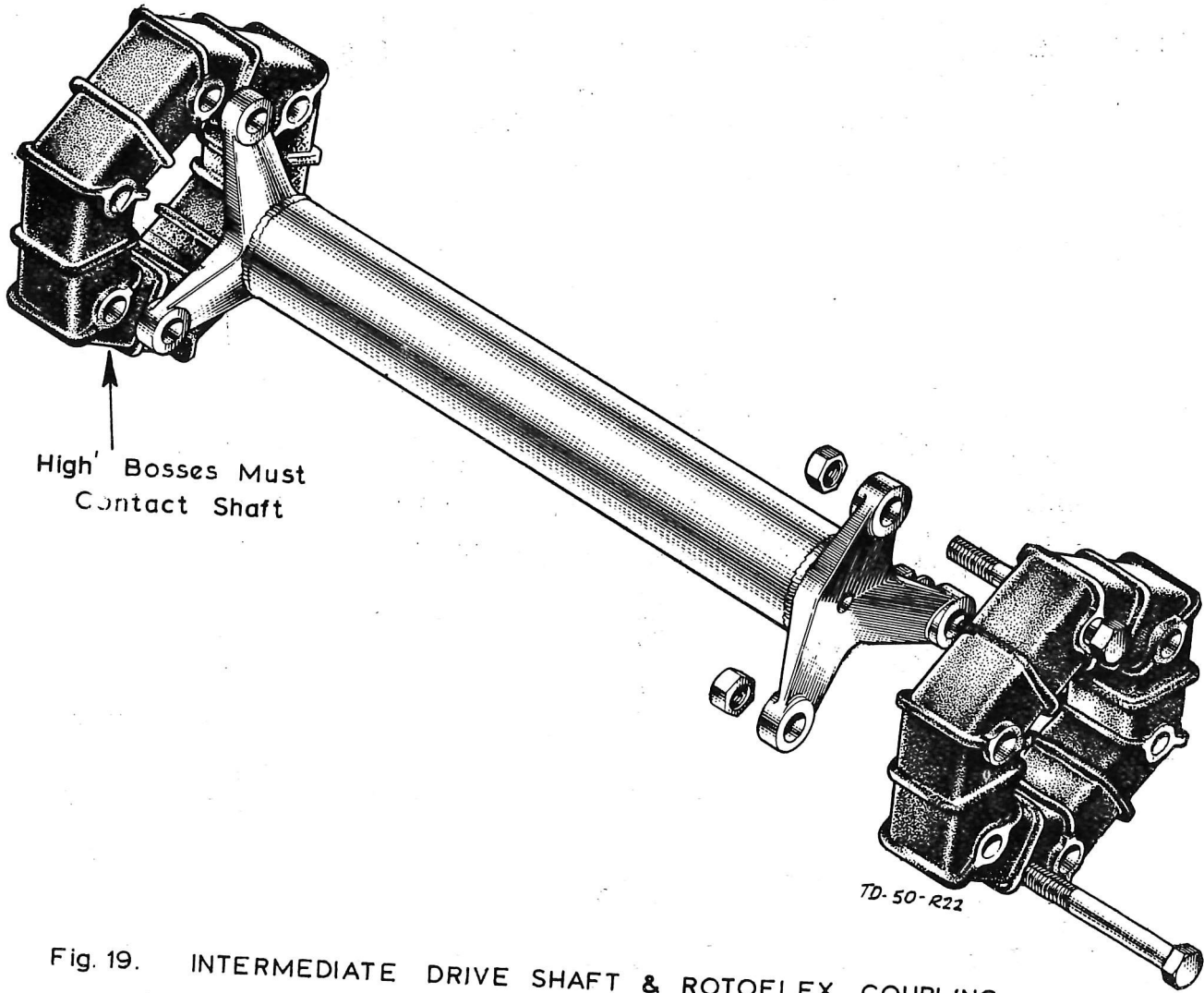

Fig. 19. INTERMEDIATE DRIVE SHAFT & ROTOFLEX COUPLING

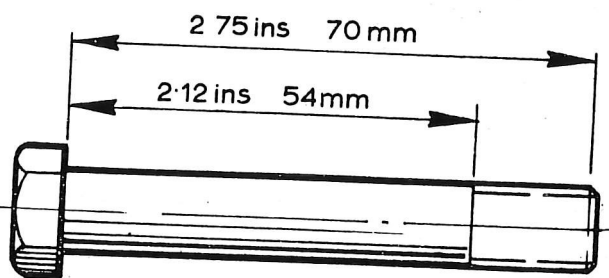

Fig 20 Coupling Bolts

TD-50-23

marked reduction in the life of the coupling. When fitting bolts, their heads MUST be in contact with the 'low' bosses in the couplings. The exception to this is the bolts which secure the brake disc and coupling to both the outboard and intermediate drive shafts, when ALL bolt heads are towards the wheel.

2. The correct bolt for the nine positions per side, other than through the brake disc, is a special UNF bolt (36 D 172 as shown in Fig.20). The other three bolts (to make 12 per side) which also retain the brake disc should be 3.25 in. X 7/16 in. in size (XUFB 0752).
3. Interleaved couplings (Part No. A50 D 034) are available from the Parts Division of Lotus Cars Limited which will reduce 'surge'. These should be fitted ideally in sets of four, but can be used in matched pairs (two inner or two outer). The couplings were introduced into current Production at Chassis No. 50/1550.
4. Carry on with remainder of replacement procedure by reversing the removal instructions

ADDITIONAL INFORMATION.

R.7. - DIFFERENTIAL UNIT REPLACEMENT.

Further to the information contained in Section 'R.2' on replacing the differential unit, note that on 'S.130' models fitted with a stiffening bracket, the following procedure should be adopted.

On cars equipped in the above manner, the same clearance between the top of the unit and the chassis crossmember (Section 'R.2') will still apply but, a maximum of only ONE washer must be used. It is possible that no washers will be necessary, the bracket itself stopping the rubber bushes from spreading.

The bracket is fitted after the differential unit is in position. Before fitting the bolts (5/16 in. X 1 $\frac{3}{4}$ in.UNC) which secure the bracket to the nosepiece of the differential unit, apply Loctite 'AV' to their threads.

