

---

SECTION S

EXHAUST SYSTEM

<u>Section</u>	<u>Description</u>	<u>Page</u>
S.1	REMOVING AND REFITTING THE MANIFOLD .....	3
S.2	REMOVING AND REFITTING THE DOWN PIPE .....	4
S.3	REMOVING AND REFITTING THE SILENCER (MUFFLER) ASSEMBLY .....	4

---

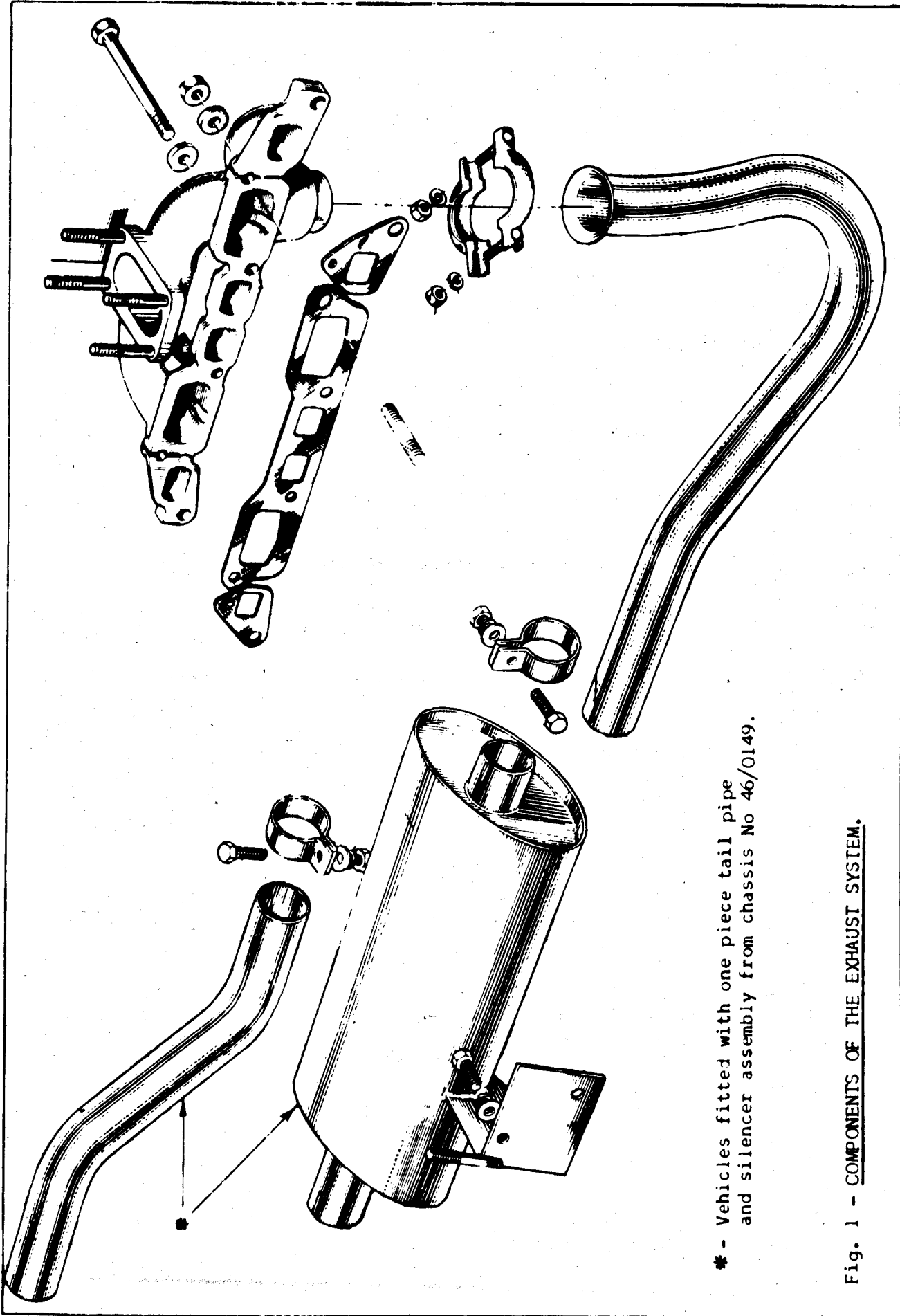

\* - Vehicles fitted with one piece tail pipe and silencer assembly from chassis No 46/0149.

Fig. 1 - COMPONENTS OF THE EXHAUST SYSTEM.

## 5.1 - REMOVING AND REFITTING THE MANIFOLD.

REMOVING.

Disconnect the battery cables (earth first).  
 Remove the rear luggage compartment, by undoing the two bolts set in the floor of the unit. Take care to note the quantity and position of the spacer washers situated between the cross member and the under-surface of the compartment.  
 Remove the air cleaner.

At the carburettor disconnect:

- the lead from the solenoid valve.
- the vacuum pipe.
- the choke wire.
- the accelerator return spring.
- the fuel pipe.
- the accelerator cable.

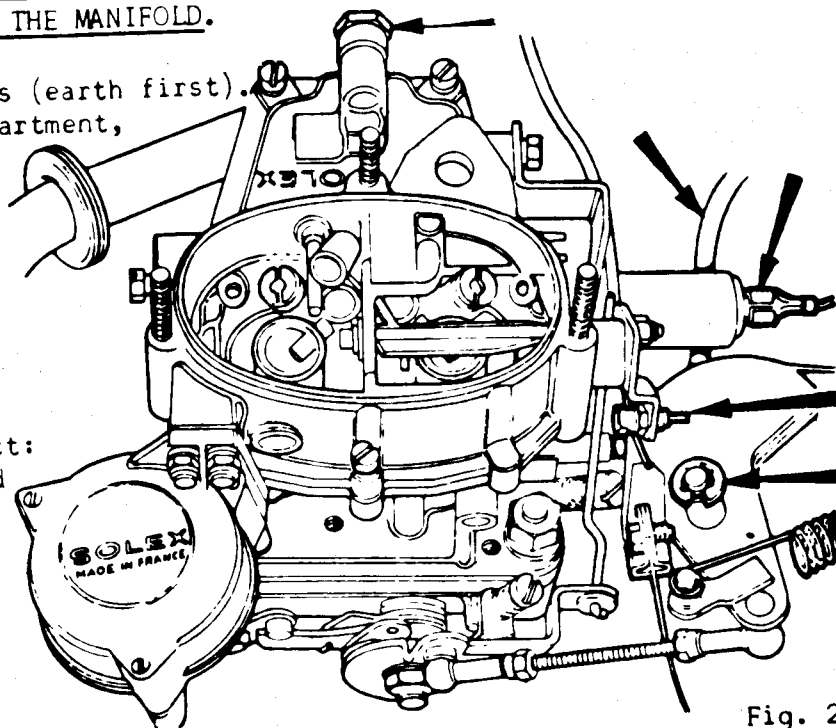

Fig. 2

Remove the 'E' clip from the accelerator quadrant post and pull off the quadrant. Remove the carburettor securing nuts and washers and lift off the instrument. Undo the two nuts on the clamp securing the down pipe to the manifold and remove the spring washers. Remove the two halves of the clamp.

Undo the four nuts, the two socket bolts of the manifold and remove the washers. Carefully remove the manifold and gasket. Clean the manifold faces.

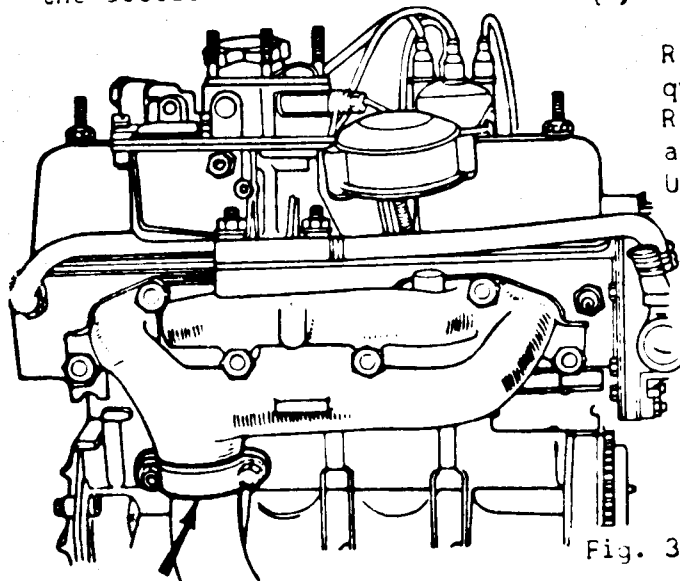

Fig. 3

Check the manifold gasket face :  
 Maximum distortion 0.20 mm (.008")

REFITTING.

Carry out the removing operations in reverse :

Fit a new gasket (of the correct type which corresponds to the inlet ports of the manifold).

The metal face of the gasket should be pressed against the cylinder head.

Tighten the manifold nuts and socket bolts to a torque of 1.5 to 2.5 m.da N (10 to 20 lb/ft).

Run the engine for 10 minutes and allow it to cool for 50 minutes.

Tighten the manifold nuts and socket bolts to a torque of 1.5 to 2.5 m.da N (10 to 20 lb/ft).

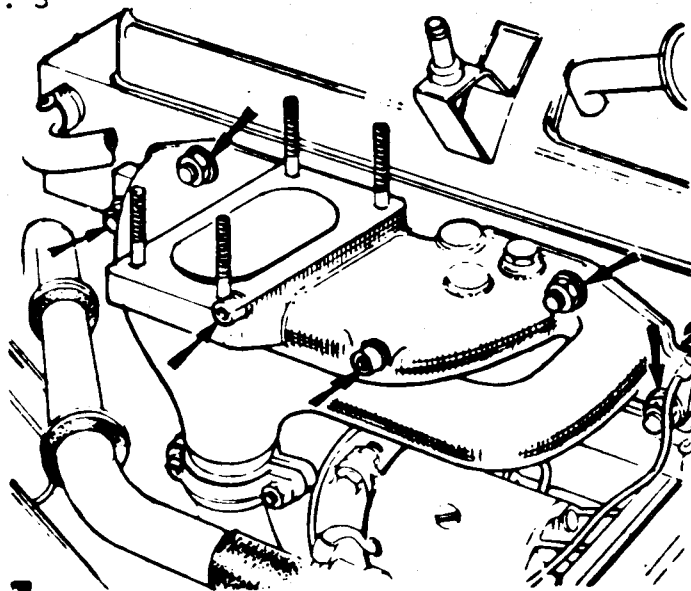

Fig. 4

5.2 - REMOVING AND REFITTING THE DOWN PIPE.REMOVING.

Disconnect the battery cables (earth first).  
 Remove the rear luggage compartment by undoing the two bolts set in the floor of the unit. Take care to note the quantity and position of the spacer washers situated between the cross member and the under-surface of the compartment.  
 Remove the two nuts on the clamp securing the down pipe to the manifold and remove the spring and plain washers.  
 Remove the two halves of the clamp.  
 Undo the nut and bolt on the pipe clamp at the front of the silencer (muffler) assembly.  
 Remove the spring and plain washer.  
 Pull the down pipe forward from within the silencer (muffler) and remove it.

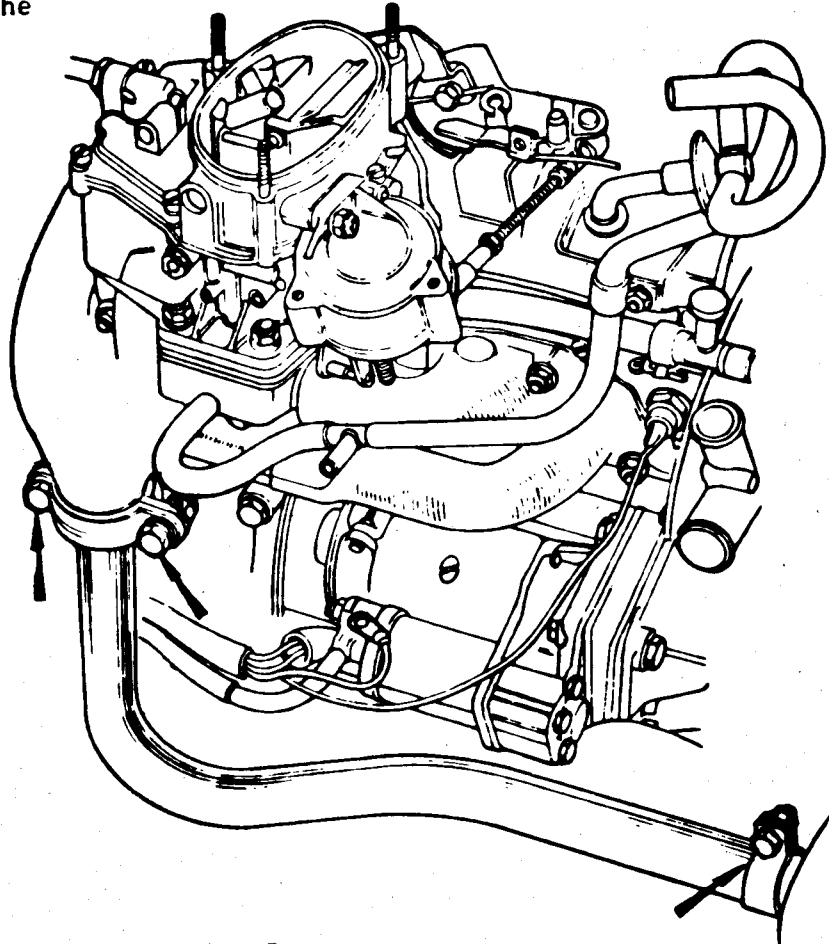

Fig. 5

REFITTING.

Carry out the removing operations in reverse.  
 Ensure that the silencer end of the down pipe is clean and free of carbon to facilitate replacement.

5.3 - REMOVING AND REFITTING THE SILENCER (MUFFLER) ASSEMBLY.REMOVING.

Disconnect the battery cables (earth first).  
 Remove the rear luggage compartment by undoing the two bolts set in the floor of the unit. Take care to note the quantity and position of the spacer washers situated between the cross member and the under surface of the compartment.  
 Undo the nut and bolt on the pipe clamp at the rear of the silencer (muffler) assembly. Remove the spring and plain washer.  
 Withdraw the tail pipe rearwards from within the silencer and remove it from the vehicle.  
 Undo the nut attaching the horizontal strap of the silencer assembly to the left-hand side of the clutch housing.  
 Remove the two bolts and washers securing the silencer (muffler) mounting bracket to the left-hand side of the gearbox.  
 Remove the silencer (muffler) by carefully pulling it rearwards off the down pipe.

REFITTING.

Carry out the removal operations in reverse.  
 Ensure that the mating ends of the silencer and pipes are free of obstructions, carbon to facilitate replacement.