



# Suppression of spurious vibrations by online loop shaping and H-infinity control in Adaptive Optics

Alberto Rigamonti

Laboratoire d'Automatique, Ecole Polytechnique Fédérale de Lausanne

Alireza Karimi, EPFL

François Wildi, University of Geneva

# Planning

- Introduction
  - *NIRPS*
- Controller
  - *Scope*
  - *Nominal performance*
  - *Optimization problem*
- Frequency estimation
  - *Recursive least square*
  - *Application to AO*
- Results
  - *Frequency tracking*
  - *Simulation*
  - *Performance*
  - *Comparison with old controller*
- Conclusion

# Introduction – NIRPS

- NIRPS will work in parallel with HARPS on the 3.6m ESO telescope.
- Size of fiber of 0.4" (diameter projected on the sky). The system will run between 250 and 1000 Hz depending on the guide star magnitude
- The WFS camera, is an OCAM2K (EMCCD) with a custom lenslet array (16x16 subapertures with only 14x14 used for the sensing).
- The DM is an ALPAO DM241 (with the high speed option). Large stroke (tip-tilt stroke  $\approx 50 \mu\text{m}$  Peak to Valley), linearity (0.03%) and fast settling time (0.44 ms).
- Real time controller is an off-the-shelf product made by ALPAO: ACE. It consists in a Matlab© Toolbox where all the hardware (WFS + DM) is interfaced in.

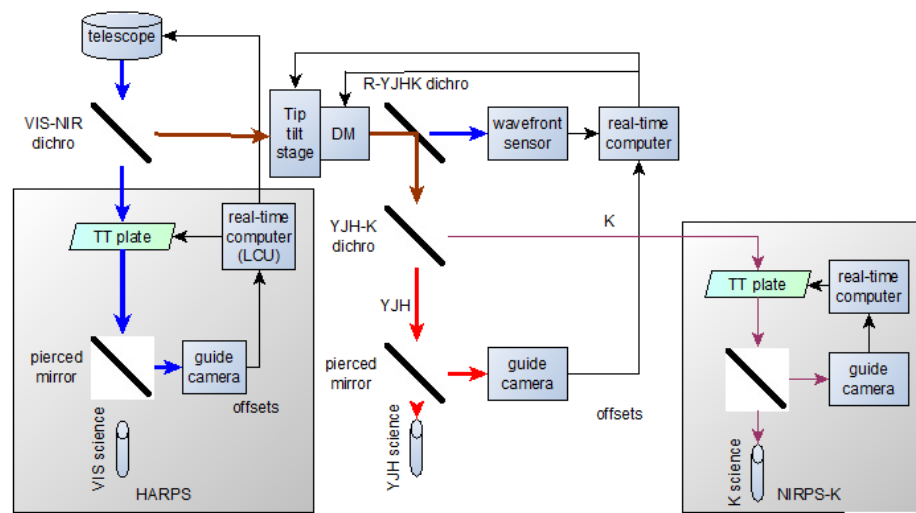

# Introduction – Goals & scope of the new controller

## Motivation

It is expected that spurious vibrations will be present once the system is installed on the telescope, originating from effects such as wind-shaking of the telescope structure or moving elements in instruments (e.g. fans, cryo-cooler and motors).

## Goals

- Have similar performances than the old controller.
- Damp one or more constant sinusoidal perturbation at unknown/slowly variable frequency.
- Keep computational load/complexity as low as possible but satisfying the two first criterions.
- (Identify the perturbation frequency)

# Controller – Definitions and structure (one freq.)

- Perturbation model  $M'_f(s, \omega_p) = \frac{s^2 + 2\mu_1\omega_p s + \omega_p^2}{s^2 + 2\mu_2\omega_p s + \omega_p^2}$ ,  $0 < \mu_2 < \mu_1 < 1$
- Internal model principle controller  $K(z, f_p) = M_f(z, 2\pi f_p) [K_0(z) + f_p K_1(z)]$
- With  $K_i(z) = \vec{\phi}^T(z) \vec{\rho}_i$  and  $\begin{cases} \phi_1(z) = 1 \\ \phi_2(z) = z^{-1} \\ \phi_n(z) = z^{-(n-1)} \end{cases}$
- Since  $DM(s) \cong 1$  for the relevant frequencies of the system which is operated at max 0.8-1kHz, the AO system is defined by  $G(z) = z^{-2}$

# Controller – Nominal performance

- Nominal performance is given by weighted infinity norm of the sensitivity function:

$$\|W_1 S\|_\infty < 1 \quad S = \frac{1}{1 + GK} = \frac{1}{1 + L}$$

- Equivalent to  $|S| < |W_1|^{-1} \quad \forall \omega$  , or  $|W_1| < |1 + L| \quad \forall \omega$

# Controller – Nominal performance

- $|W_1| < |1 + L|$  indicates that  $L$  must be outside of a circle of radius  $W_1$  centered at  $(-1;0)$  in the Nyquist diagram.
- Equivalent to saying that  $L$  must lie below a line  $d^*$  tangent to the circle and perpendicular to the line between  $L$  and  $-1$ .
- However  $d^*$  is dependent of the controller parameters  $\rho$
- To avoid this, a desired open-loop transfer function  $L_d$  can be given which makes  $d$  independent of the controller.

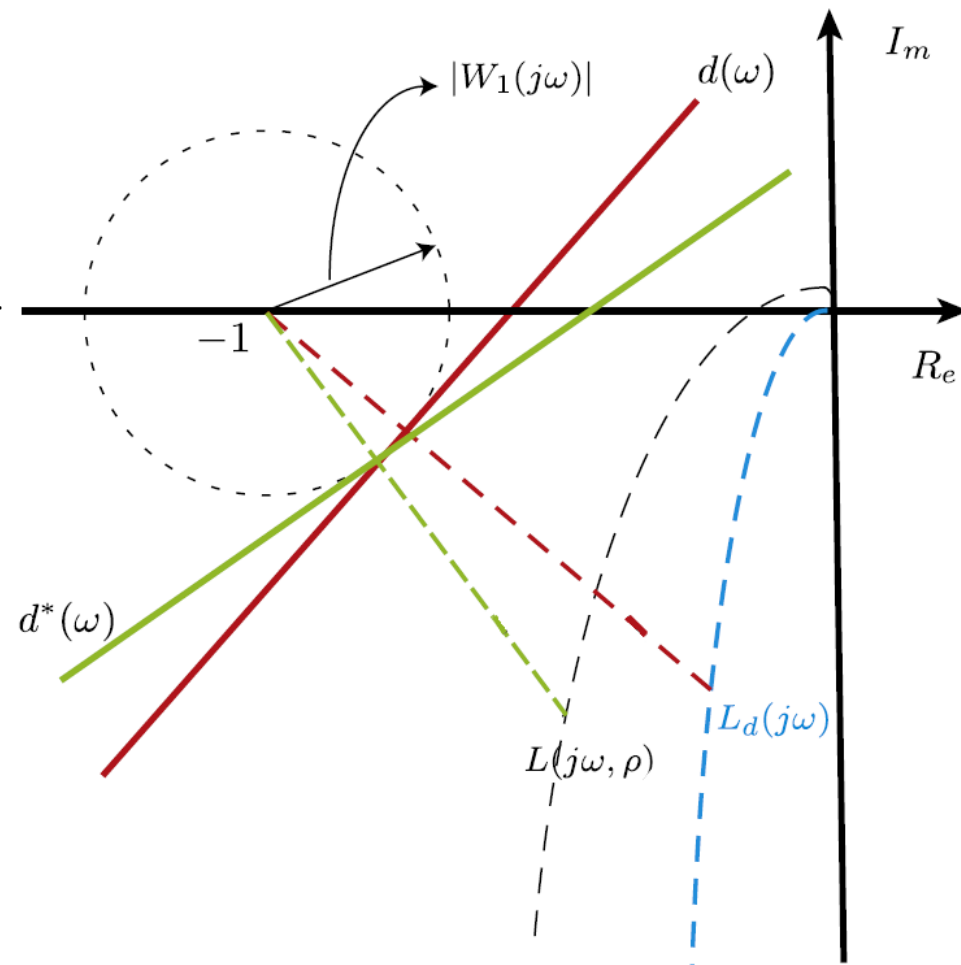

# Controller – Nominal performance

- Equation for  $d$  :  $\left| W_1(e^{j\omega}) \left[ 1 + L_d(e^{j\omega}) \right] \right| - \mathbf{Im}\{L_d(e^{j\omega})\}y - \left[ 1 + \mathbf{Re}\{L_d(e^{j\omega})\} \right] [1 + x] = 0$

- So the constraint becomes, at a given  $\omega$ :

$$\left| W_1(e^{j\omega}) \left[ 1 + L_d(e^{j\omega}) \right] \right| - \mathbf{Im}\{L_d(j\omega)\} \mathcal{I}(\omega) \vec{\rho} - \mathbf{Re}\{ \left[ 1 + L_d(e^{j\omega}) \right] \} [1 + \mathcal{R}(\omega) \vec{\rho}] < 0$$

With  $\mathcal{R}(\omega) + j \cdot \mathcal{I}(\omega) = G(e^{j\omega}) \vec{\phi}^T(e^{j\omega})$

- By using a grid on  $\omega$ , we get a set of constraints linear in  $\rho$ .



# Controller – Terms

- Weighting function :

$$W_1(z, \omega_p) = M_f(z, \omega_p) \cdot \frac{1 - \alpha}{1 - \alpha z^{-1}} \quad \text{with } \alpha = e^{-\omega_c T}$$

- Desired open loop transfer function  $L_d(z, \omega_p)$  obtained by computing a stabilizing controller with similar performance to the classic integrator controller but containing internal perturbation model. Then using it to compute  $L_d$
- A modulus margin constraint of 0.5 is also added.

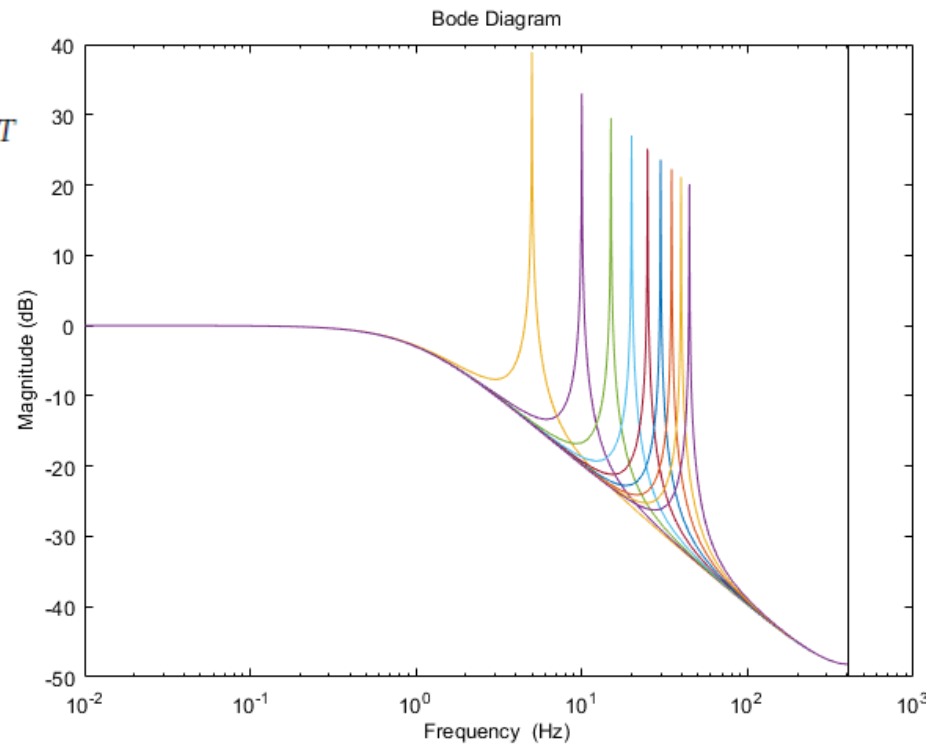

$$|S| < |W_1|^{-1} \quad \forall \omega$$

# Controller – Synthesis (one frequency)

- For each perturbation model at pulsation  $\omega_{p,l} = 2\pi f_{p,l}$  we obtain a weighting function  $W_1(z, \omega_p)$  and a desired open-loop transfer function  $L_d(z, \omega_p)$ .
- Best performance, by minimizing  $\|W_1 S\|_\infty$  i.e minimal  $\gamma$  s.t.  $\|W_1 S\|_\infty < \gamma < 1$
- Design a gain-scheduled controller linear in perturbation frequency by bisection

$$\begin{aligned}
 & \min \quad \gamma \\
 & \text{subject to} \\
 & \gamma^{-1} \left| W_1(e^{j\omega_k}, \omega_{p,l}) \right| \left| 1 + L_d(e^{j\omega_k}, \omega_{p,l}) \right| \\
 & \quad - \operatorname{Re} \left\{ \left[ 1 + L_d(e^{-j\omega_k}, \omega_{p,l}) \right] \left[ 1 + L(e^{j\omega_k}, \vec{\rho}(\omega_{p,l})) \right] \right\} < 0 \\
 & 0.5 \left| 1 + L_d(e^{j\omega_k}, \omega_{p,l}) \right| \\
 & \quad - \operatorname{Re} \left\{ \left[ 1 + L_d(e^{-j\omega_k}, \omega_{p,l}) \right] \left[ 1 + L(e^{j\omega_k}, \vec{\rho}(\omega_{p,l})) \right] \right\} < 0 \quad \vec{\rho} = \vec{\rho}_0 + \vec{\rho}_1 f_p.
 \end{aligned}$$

For  $f_{p,1}=5$  to  $f_{p,L}=50$  (5Hz step) and  $\omega_1=1e-3$  to  $\omega_k$ =Nyquist frequency (5000 points)

$$K(z, f_p) = M_f(z, 2\pi f_p) [K_0(z) + f_p K_1(z)]$$

# Controller – Synthesis (one frequency)

$$K(z, f_p) = M_f(z, 2\pi f_p) [K_0(z) + f_p K_1(z)]$$

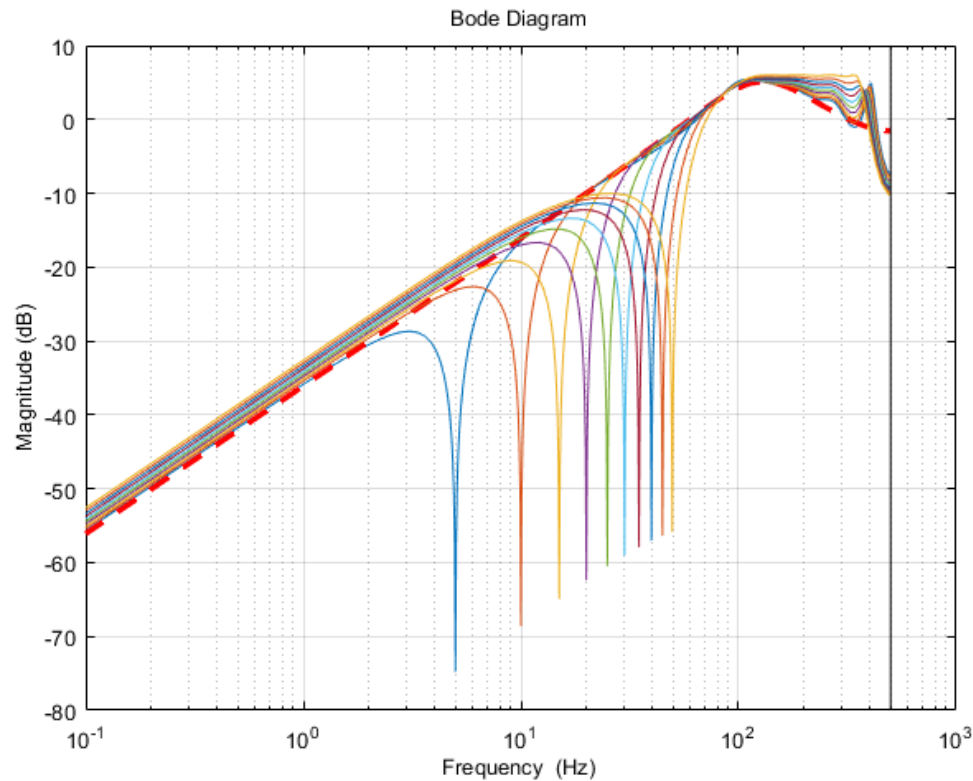

- $K_0$  and  $K_1$  are of order  $n=7$
- Classical integrator in red dashed line

# Controller – Synthesis (Multiple frequencies)

- The same approach is used for two and three frequencies.
- The only difference is that the frequency and model indexes are different. For each model index a pair/triplet of frequencies is associated.
- For instance, with two frequencies model  $l=1$  is for perturbation at 5/10 Hz,  $l=2$  is 5/15 etc.

$$K(z, f_p) = [K_0(z) + K_1(z)f_{p,1} + K_2(z)f_{p,2}] M_{f,2}(z, 2\pi f_{p,1}, 2\pi f_{p,2})$$

# Frequency estimation – Perturbation estimation

- $H$  models the perturbation
- $w$  is a white noise, and  $p$  is a sinusoidal perturbation
- $a$ ,  $p$  and  $e$  are not accessible
- The sequence of measurements  $e_{meas}$  and commands to the mirror  $y$  are available
- We assume that  $DM(s) \cong 1$

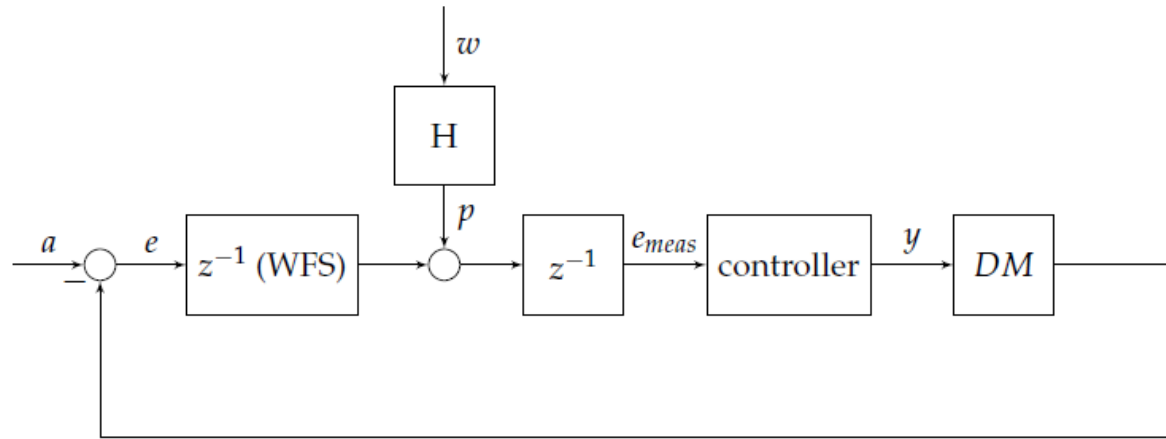

# Frequency estimation – Perturbation estimation

- Three models of the perturbation, for one, two or three perturbations.

$$H(z^{-1}) = \frac{P(z^{-1})}{W(z^{-1})} = \frac{1 + c_1 z^{-1} + c_2 z^{-2}}{1 + \theta z^{-1} + z^{-2}} \quad \theta = -2\cos(2\pi f_{\text{pert}} T_s)$$

$$H(z^{-1}) = \frac{1 + c'_1 z^{-1} + c'_2 z^{-2} + c'_3 z^{-3} + c'_4 z^{-4}}{1 + \alpha_1 z^{-1} + \alpha_2 z^{-2} + \alpha_1 z^{-3} + z^{-4}} \quad \begin{cases} \alpha_1 = \theta_1 + \theta_2 \\ \alpha_2 = 2 + \theta_2 \theta_1 \end{cases}$$

$$H(z^{-1}) = \frac{1 + c'_1 z^{-1} + c'_2 z^{-2} + c'_3 z^{-3} + c'_4 z^{-4} + c'_5 z^{-5} + c'_6 z^{-6}}{1 + \alpha_1 z^{-1} + \alpha_2 z^{-2} + \alpha_3 z^{-3} + \alpha_2 z^{-4} + \alpha_1 z^{-5} + z^{-6}} \quad \begin{cases} \alpha_1 = \theta_1 + \theta_2 + \theta_3 \\ \alpha_2 = \theta_1 \theta_2 + \theta_2 \theta_3 + \theta_3 \theta_1 + 3 \\ \alpha_3 = \theta_1 \theta_2 \theta_3 + 2\alpha_1 \end{cases}$$

# Frequency estimation – Parameter vector (one freq.)

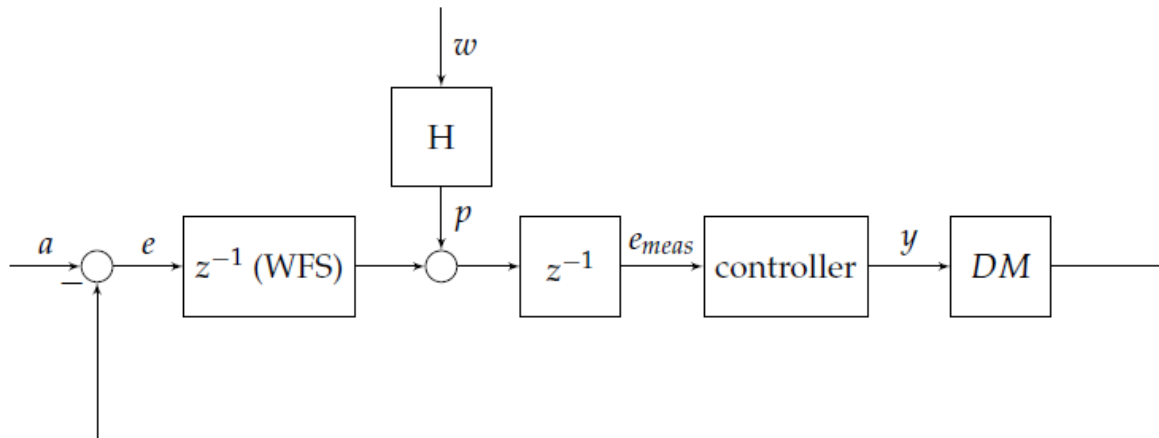

$$H(z^{-1}) = \frac{P(z^{-1})}{W(z^{-1})} = \frac{1 + c_1 z^{-1} + c_2 z^{-2}}{1 + \theta z^{-1} + z^{-2}}$$

$$\begin{cases} z(k+1) = [p(k+1) + p(k-1)] = w(k+1) + c_1 w(k) + c_2 w(k-1) - [\theta(p(k))] \\ \hat{z}(k+1) = \hat{c}_1 w(k) + \hat{c}_2 w(k-1) - [\hat{\theta}(p(k))] \end{cases}$$

$$\begin{aligned} \Rightarrow \epsilon^0(k+1) &= z(k+1) - [\hat{c}_1 \epsilon(k) + \hat{c}_2 \epsilon(k-1) + [\hat{\theta}(-p(k))]] \\ &= z(k+1) - \hat{\Theta}^T(k) \psi(k) \end{aligned}$$

$$\begin{aligned} \hat{\Theta}(k) &= [\hat{\theta}(k) \quad \hat{c}_1(k) \quad \hat{c}_2(k)]^T \\ \psi(k) &= [-p(k) \quad \epsilon(k) \quad \epsilon(k-1)]^T \end{aligned}$$

# Frequency estimation – Parameter vector (two freq.)

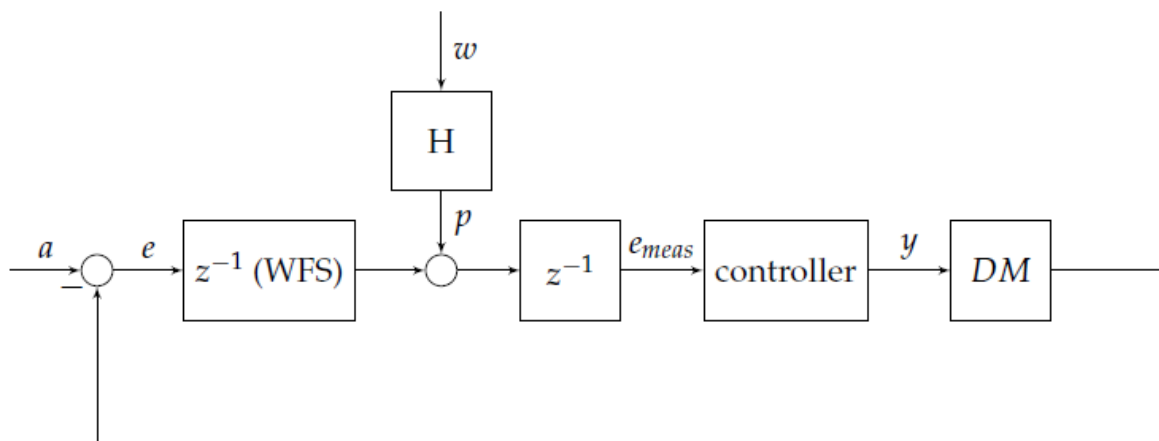

$$H(z^{-1}) = \frac{1 + c'_1 z^{-1} + c'_2 z^{-2} + c'_3 z^{-3} + c'_4 z^{-4}}{1 + \alpha_1 z^{-1} + \alpha_2 z^{-2} + \alpha_1 z^{-3} + z^{-4}}$$

$$z(k+1) = [p(k+1) + p(k-3)]$$

$$\hat{\Theta}(k) = [\hat{\alpha}_1(k) \quad \hat{\alpha}_2(k) \quad \hat{c}'_1(k) \quad \hat{c}'_2(k) \quad \hat{c}'_3(k) \quad \hat{c}'_4(k)]^T$$

$$\psi(k) = [(-p(k) - p(k-2)) \quad -p(k-1) \quad \epsilon(k) \quad \epsilon(k-1) \quad \epsilon(k-2) \quad \epsilon(k-3)]^T$$



# Frequency estimation – Perturbation p estimation

- Need of an estimation of p
- a , p and e are not accessible
- The sequence of measurements  $e_{meas}$  and commands to the mirror y are available
- Since 
$$e_{meas} = pz^{-1} + ez^{-2}$$
$$e(k) = a(k) - y(k)$$
- An estimation of p can be obtained from  $e_{meas}$  and y

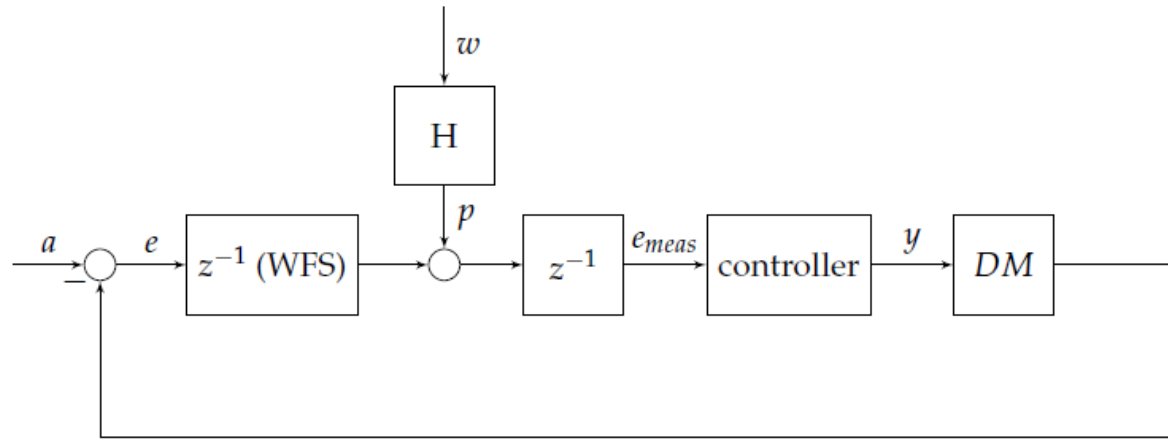

$$\hat{e}(k) = \hat{a}(k) - y(k)$$

$$\Rightarrow \hat{p}(k+1) = e_{meas}(k+2) - \hat{e}(k)$$

$$= e_{meas}(k+2) + y(k) - y(k-2)$$

# Frequency estimation – Summary

$$1. \quad \hat{p}(k+1) = e_{meas}(k+2) - \hat{e}(k) \\ = e_{meas}(k+2) + y(k) - y(k-2)$$

2. Build  $z(k+1)$  and  $\psi(k)$

$$3. \quad \epsilon^0(k+1) = z(k+1) - \hat{\Theta}^T(k)\psi(k)$$

$$4. \quad \epsilon(k+1) = \frac{\epsilon^0(k+1)}{1 + \psi^T(k)F(k)\psi(k)}$$

$$5. \quad \hat{\Theta}(k+1) = \hat{\Theta}(k) + F(k)\psi(k)\epsilon(k+1)$$

$$6. \quad F(k+1) = \frac{1}{\lambda_1(k)} \left[ F(k) - \frac{F(k)\psi(k)\psi^T(k)F(k)}{\frac{\lambda_1(k)}{\lambda_2(k)} + \psi^T(k)F(k)\psi(k)} \right]$$

7.  $\lambda_1$  and  $\lambda_2$  to keep the trace constant

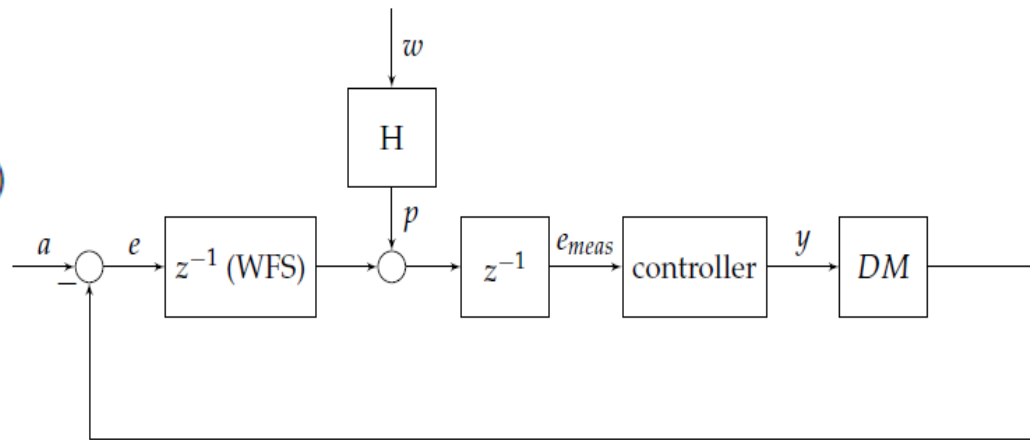

# Results – Controller (simulation)

- Simulation with a controller tuned at the exact frequency of the perturbation
- Input signal corresponding to a realistic atmospheric profile
- Results are close to those obtained with the classic integrator controller when no disturbance is present.

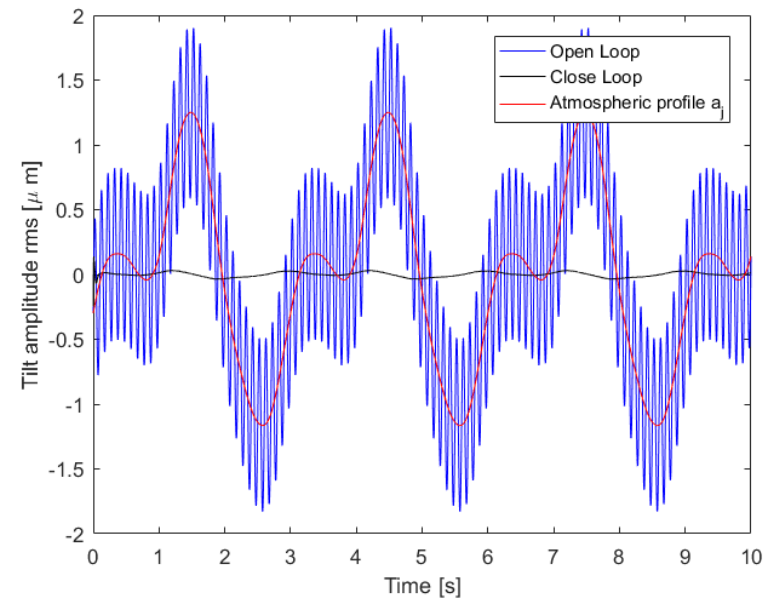
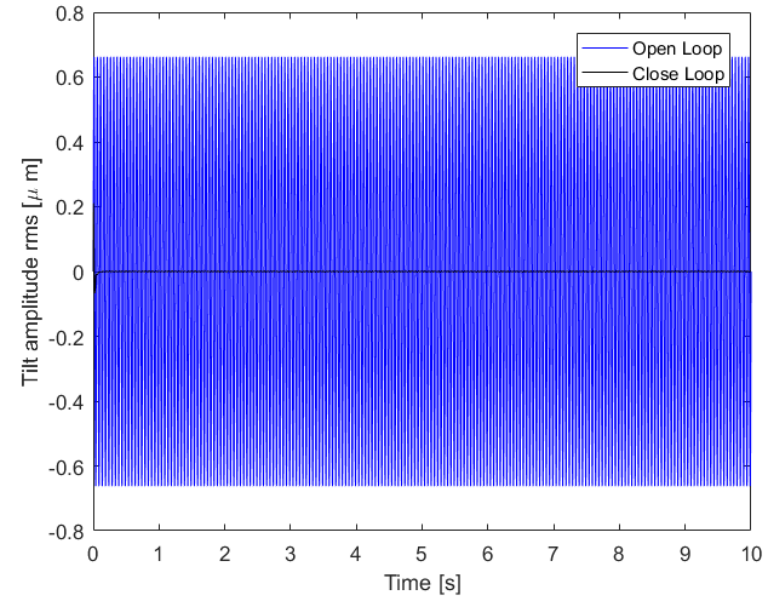

# Results – Controller (test Bench)

- On the test bench, perturbations are inserted either by adding a command to the DM and/or with a DC motor with an eccentric mass.
- Step application of the disturbances via DM after 10000 samples at 814 Hz
- Controller tuning start at 20000 samples
- Amplitude equivalent to 150 [mas]

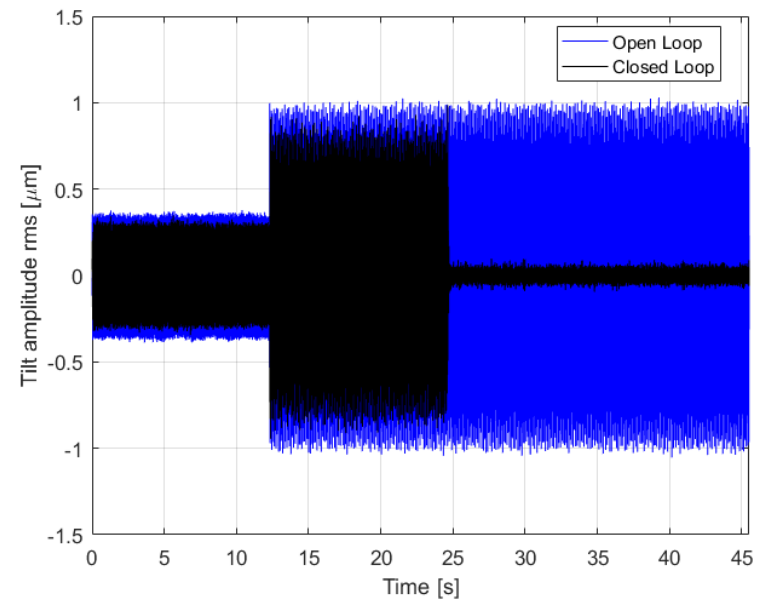
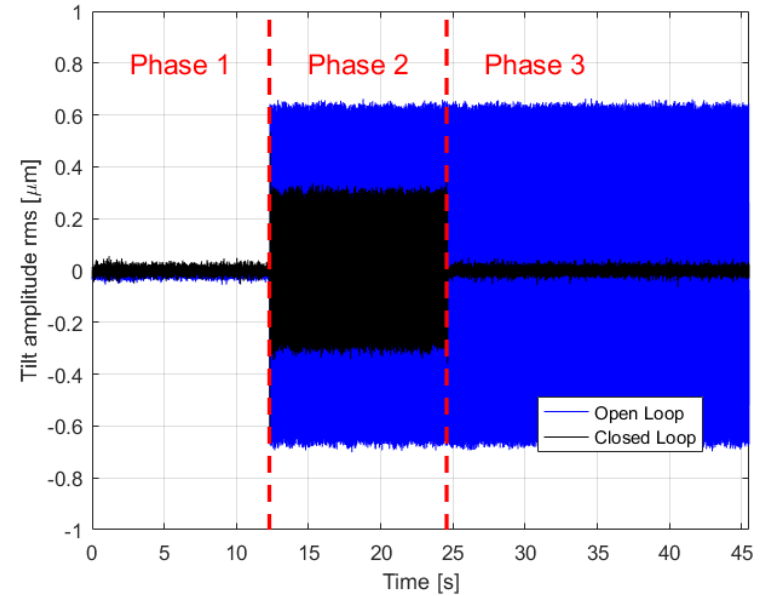

# Results – Controller (test Bench)

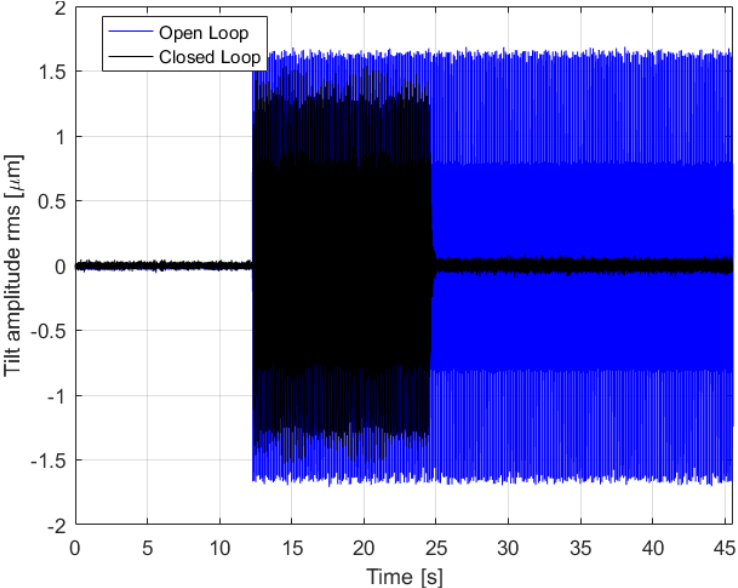
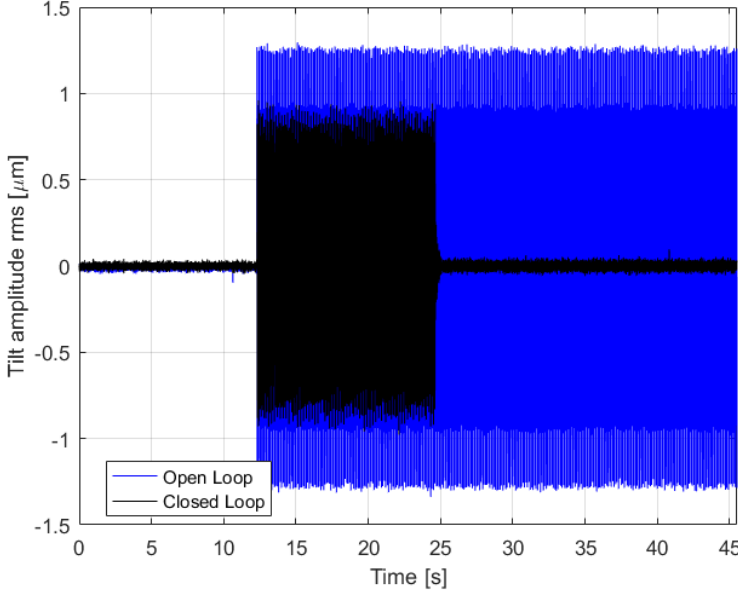
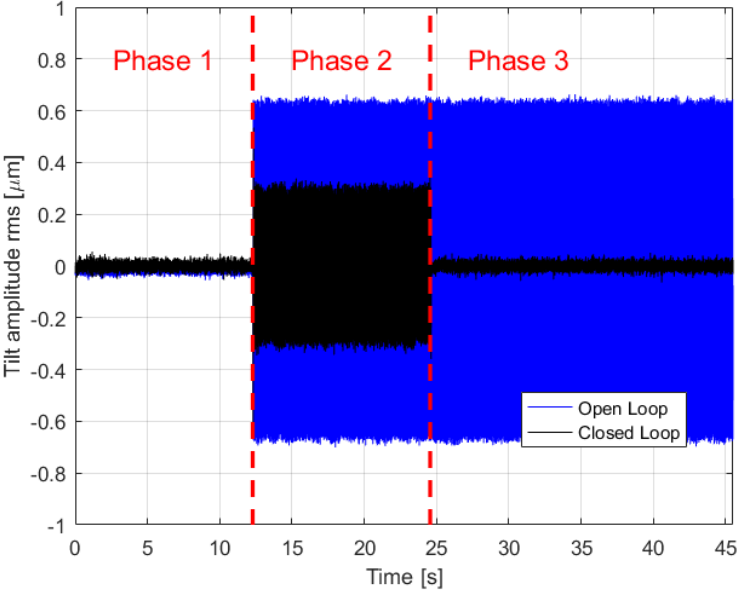

# Results – Online frequency tracking

- Verification of tracking results via step and linear change in frequencies
- In both cases, the algorithm is able to track the frequency variation

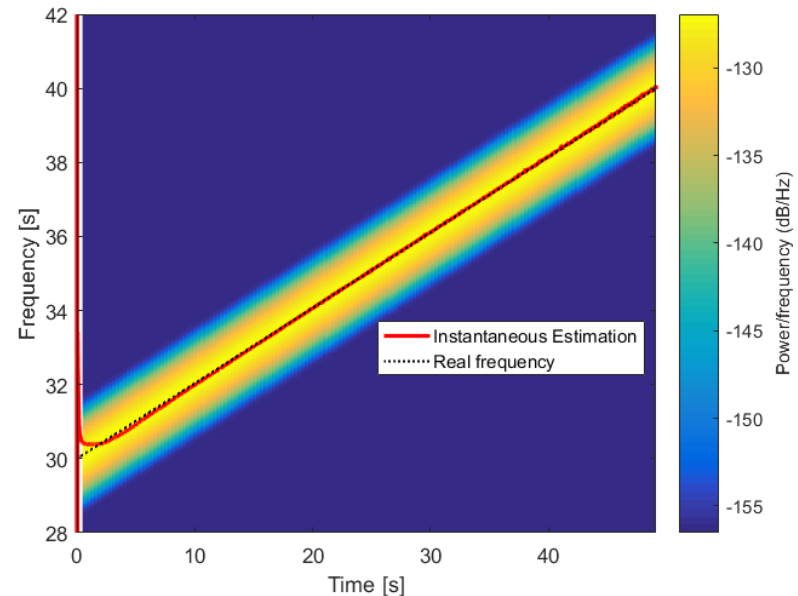
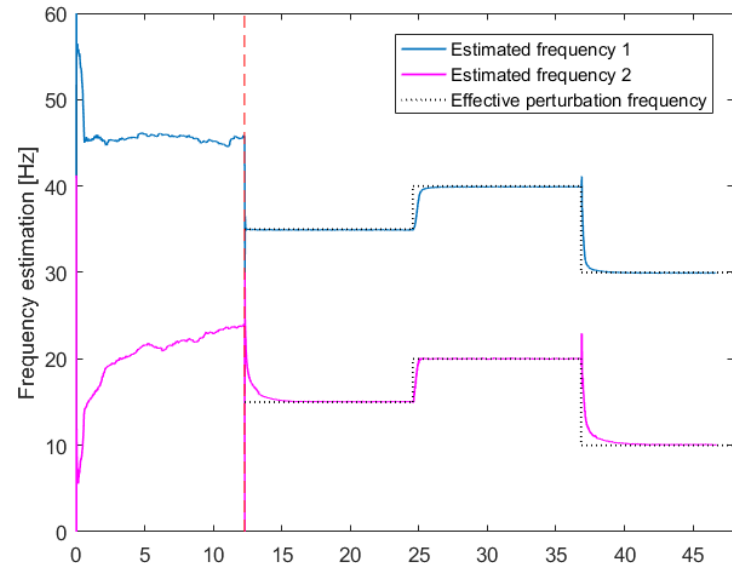

# Results – Controller (Performance metrics)

- Attenuation with respect to open-loop  $Att[dB] = 20\log_{10} \left( \frac{RMS_{CL}}{RMS_{OL}} \right)$
- Ratio between closed-loop and without disturbance  $Perf = \frac{RMS_{CL}}{RMS_{ND}}$
- Attenuation at disturbance frequency  $DA[dB] = 10\log_{10} \left( \frac{PSD_{CL}}{PSD_{OL}} \right) |_{f=f_p}$
- Comparison with integrator controller : Ratio of closed-loop RMS and difference in attenuation at disturbance frequency

# Results – Controller (one frequency)

- In one case, disturbance applied via the mirror and in one case via DC motor

$f_p$ [Hz]	$f_{estimated}$ [Hz]	$\Delta f$ [Hz]	$Att$ [dB]	$Perf$ [-]	$DA$ [dB]
10	9.9942	0.0058	-38.9428	1.0248	-56.30
15	14.9776	0.0224	-31.2430	1.0583	-53.35
20	20.0261	0.0261	-31.0064	1.0236	-50.40
40	39.9409	0.0591	-28.2519	1.3538	-33.50
45	44.935	0.065	-29.5308	1.0563	-30.49

$f_p$ [Hz]	$RMS_{OL}$ [ $\mu m$ ]	$RMS_{CL}$ [ $\mu m$ ]	$RMS_{ND}$ [ $\mu m$ ]	$Att$ [dB]	$Perf$ [-]	$DA$ [dB]
17.44	0.2730	0.0147	0.0128	-25.38	1.1484	-51.0
17.61	0.2867	0.0144	0.0128	-25.98	1.1250	-60.5
18.845	0.5700	0.0217	0.0128	-28.39	1.6953	-51.1
19.184	0.8042	0.0212	0.0128	-31.58	1.6563	-51.7
20.23	2.7810	0.0327	0.0128	-38.59	2.5547	-48.2
20.93	0.5562	0.0152	0.0128	-31.27	1.1875	-54.6

- $DA > 30$  [dB] and attenuation with respect to open-loop  $>25$  [dB] and identification within 0.1 [Hz]



# Results – Controller (two frequencies)

- In one case, disturbance applied via the mirror only and in one case via DC motor and mirror

$f_{p,1}$ [Hz]	$f_{p,2}$ [Hz]	$f_{estimated,1}$ [Hz]	$f_{estimated,2}$ [Hz]	$\Delta f_1$ [Hz]	$\Delta f_2$ [Hz]	$Att$ [dB]	$Perf$ [-]	$DA$ [dB]
15	25	15.07	24.9	0.07	0.1	-29.1754	1.5302	-31.6/-32.3
15	35	14.9978	34.9532	0.0022	0.0468	-32.1949	1.0321	-47.8/-46.0
15	45	14.9821	44.9284	0.0179	0.0716	-28.4756	1.5280	-45.8/-33.5
25	35	24.9842	34.974	0.0158	0.026	-31.6973	1.1486	-42.1/-38.1
25	45	24.9645	44.9414	0.0355	0.0586	-28.0569	1.7603	-38.3/-31.6
35	45	34.9409	44.936	0.0591	0.064	-25.9938	2.1745	-31.4/-30.9

$f_p$ [Hz]	$RMS_{OL}$ [ $\mu m$ ]	$RMS_{CL}$ [ $\mu m$ ]	$RMS_{ND}$ [ $\mu m$ ]	$Att$ [dB]	$Perf$ [-]	$DA$ [dB]
16.93/30	0.5104	0.0161	0.0131	-30.02	1.2290	-36.6/-38.8
17.27/45	0.52	0.0272	0.0131	-25.63	2.0763	-46.6/-29.2
19.01/40	0.8444	0.027	0.0131	-29.90	2.0611	-40.1/-30.4
25.11/40	0.4665	0.0244	0.0131	-25.63	1.8626	-37.7/-33.5

- $DA > 30$  [dB] and attenuation with respect to open-loop  $>25$  [dB] and identification within 0.1 [Hz]

# Results – Controller (three frequencies)

$f_{p,1}$ [Hz]	$f_{p,2}$ [Hz]	$f_{p,3}$ [Hz]	$f_{estimated,1}$ [Hz]	$f_{estimated,2}$ [Hz]	$f_{estimated,3}$ [Hz]	$\Delta f_1$ [Hz]	$\Delta f_2$ [Hz]	$\Delta f_3$ [Hz]
10	30	40	10.2547	30.2100	40.0395	0.2547	0.2100	0.0395
10	35	45	10.0041	34.8960	44.7966	0.0041	0.1040	0.2034
15	35	45	15.0236	35.1305	45.1020	0.0236	0.1305	0.1020
21.29	35	45	21.4582	35.1099	45.0704	0.1682	0.1099	0.0704
25	35	50	24.9786	35.0222	49.9179	0.0214	0.0222	0.0821

$f_p$ [Hz]	$RMS_{OL}$ [ $\mu m$ ]	$RMS_{CL}$ [ $\mu m$ ]	$RMS_{ND}$ [ $\mu m$ ]	$Att$ [dB]	$Perf$ [–]	$DA$ [dB]
10 / 30 / 40	0.8019	0.0481	0.0184	-24.4395	2.6141	-33.1/-33.1/-31.5
10/35/45	0.8010	0.0497	0.0193	-24.1455	2.5751	-32.3/-36.1/-25.2
15/35/45	0.7959	0.0250	0.0142	-30.0584	1.7606	-38.3/-36.5/-36.6
21.29/35/45	0.7646	0.0392	0.0190	-25.8030	2.0632	-32.9/-31.1/-35.5
25/35/50	0.7949	0.0340	0.0169	-27.3767	2.0118	-38.3/-33.0/-26.9

- $DA > 25$  [dB] and attenuation with respect to open-loop  $>24$  [dB]

# Controller – Comparison with integrator controller

$f_p$ [Hz]	$RMS_{CL,o}$ [ $\mu m$ ]	$RMS_{CL,n}$ [ $\mu m$ ]	$RMS_{ratio}$ [%]	$DA_o$ [dB]	$DA_n$ [dB]	$\Delta DA$ [dB]
10	0.4326	0.0124	2.8664	-22.00	-56.30	-34.30
15	0.1927	0.0127	6.5906	-20.30	-53.35	-33.05
20	0.2636	0.0130	4.9317	-15.30	-50.40	-35.10
40	0.6083	0.0176	2.8933	0.20	-33.50	-33.70
45	0.7032	0.0150	2.1331	2.51	-30.49	-33.00

$f_p$ [Hz]	$RMS_{CL,o}$ [ $\mu m$ ]	$RMS_{CL,n}$ [ $\mu m$ ]	$RMS_{ratio}$ [%]	$DA_o$ [dB]	$DA_n$ [dB]	$\Delta DA$ [dB]
15/25	0.3903	0.0228	5.8417	-17.7/-8.3	-31.6/-32.3	-13.9/-24.0
15/35	0.5462	0.0161	2.9476	-18.6/-1.2	-47.8/-46.0	-29.2/-44.8
15/45	0.7244	0.0246	3.3959	-16.9/4.1	-45.8/-33.5	-28.9/-37.6
25/35	0.6139	0.0170	2.7692	-6.6/-1.1	-42.1/-38.1	-35.5/-37.0
25/45	0.7760	0.0257	3.3119	-10.1/4.1	-38.3/-31.6	-28.2/-35.7
35/45	0.8663	0.0324	3.7400	-1.4/3.3	-31.4/-30.9	-30.0/-34.2

$f_p$ [Hz]	$RMS_{CL,o}$ [ $\mu m$ ]	$RMS_{CL,n}$ [ $\mu m$ ]	$RMS_{ratio}$ [%]	$DA_o$ [dB]	$DA_n$ [dB]	$\Delta DA$ [dB]
10./30/40	0.7321	0.0481	6.5701	-19.8/-5.6/0.4	-33.1/-33.1/-31.5	-13.3/-27.5/-31.9
10./35/45	0.8614	0.0497	5.7697	-16.8/-1.5/3.6	-32.3/-36.1/-25.2	-15.5/-34.6/-28.8
15./35/45	0.8751	0.0250	2.8568	-18./-1.5/3.5	-38.3/-36.5/-36.6	-20.3/-35./-40.1
21.29/35/45	0.8887	0.0392	4.4109	-11.7/-1.6/3.8	-32.9/-31.1/-35.5	-21.2/-29.5/-39.3
25./35/50	0.9781	0.0340	3.4761	-10.2/-1.2/5.7	-38.3/-33.0/-26.9	-28.1/-31.8/-32.6

- Clear improvement in the closed-loop RMS values in all three cases (>93%)

# Conclusion

---

- The frequency estimation is computed on-line, thus avoiding the need for additional measuring instruments for that purpose.
- Real-time update to match the perturbation frequency.
- Optimization is carried out only at initialization.
- Algorithm tracks accurately a time-varying frequency.
- Clear improvement in RMS closed loop values and attenuation at disturbance frequency.

---

**Thank you**